

Programmable Controller

MELSEC iQ-R
series

MELSEC iQ-R Motion Controller Programming Manual (Program Design)

-R16MTCPU
-R32MTCPU
-R64MTCPU



SAFETY PRECAUTIONS

(Read these precautions before using this product.)

Before using this product, please read this manual and the relevant manuals carefully and pay full attention to safety to handle the product correctly.

The precautions given in this manual are concerned with this product only. Refer to MELSEC iQ-R Module Configuration Manual for a description of the PLC system safety precautions.

In this manual, the safety precautions are classified into two levels: "  WARNING" and "  CAUTION".

 WARNING	Indicates that incorrect handling may cause hazardous conditions, resulting in death or severe injury.
 CAUTION	Indicates that incorrect handling may cause hazardous conditions, resulting in minor or moderate injury or property damage.

Under some circumstances, failure to observe the precautions given under "  CAUTION" may lead to serious consequences.

Observe the precautions of both levels because they are important for personal and system safety.

Make sure that the end users read this manual and then keep the manual in a safe place for future reference.

[Design Precautions]

WARNING

- Configure safety circuits external to the programmable controller to ensure that the entire system operates safely even when a fault occurs in the external power supply or the programmable controller. Failure to do so may result in an accident due to an incorrect output or malfunction.
 - (1) Emergency stop circuits, protection circuits, and protective interlock circuits for conflicting operations (such as forward/reverse rotations or upper/lower limit positioning) must be configured external to the programmable controller.
 - (2) When the programmable controller detects an abnormal condition, it stops the operation and all outputs are:
 - Turned off if the overcurrent or overvoltage protection of the power supply module is activated.
 - Held or turned off according to the parameter setting if the self-diagnostic function of the CPU module detects an error such as a watchdog timer error.
 - (3) All outputs may be turned on if an error occurs in a part, such as an I/O control part, where the CPU module cannot detect any error. To ensure safety operation in such a case, provide a safety mechanism or a fail-safe circuit external to the programmable controller. For a fail-safe circuit example, refer to "General Safety Requirements" in the MELSEC iQ-R Module Configuration Manual.
 - (4) Outputs may remain on or off due to a failure of a component such as a relay and transistor in an output circuit. Configure an external circuit for monitoring output signals that could cause a serious accident.
 - In an output circuit, when a load current exceeding the rated current or an overcurrent caused by a load short-circuit flows for a long time, it may cause smoke and fire. To prevent this, configure an external safety circuit, such as a fuse.
 - Configure a circuit so that the programmable controller is turned on first and then the external power supply. If the external power supply is turned on first, an accident may occur due to an incorrect output or malfunction.
-

[Design Precautions]

WARNING

- For the operating status of each station after a communication failure, refer to manuals relevant to the network. Incorrect output or malfunction due to a communication failure may result in an accident.
 - When connecting an external device with a CPU module or intelligent function module to modify data of a running programmable controller, configure an interlock circuit in the program to ensure that the entire system will always operate safely. For other forms of control (such as program modification, parameter change, forced output, or operating status change) of a running programmable controller, read the relevant manuals carefully and ensure that the operation is safe before proceeding. Improper operation may damage machines or cause accidents.
 - Especially, when a remote programmable controller is controlled by an external device, immediate action cannot be taken if a problem occurs in the programmable controller due to a communication failure. To prevent this, configure an interlock circuit in the program, and determine corrective actions to be taken between the external device and CPU module in case of a communication failure.
 - Do not write any data to the "system area" and "write-protect area" of the buffer memory in the module. Also, do not use any "use prohibited" signals as an output signal from the CPU module to each module. Doing so may cause malfunction of the programmable controller system. For the "system area", "write-protect area", and the "use prohibited" signals, refer to the user's manual for the module used.
 - If a communication cable is disconnected, the network may be unstable, resulting in a communication failure of multiple stations. Configure an interlock circuit in the program to ensure that the entire system will always operate safely even if communications fail. Failure to do so may result in an accident due to an incorrect output or malfunction.
 - To maintain the safety of the programmable controller system against unauthorized access from external devices via the network, take appropriate measures. To maintain the safety against unauthorized access via the Internet, take measures such as installing a firewall.
 - Configure safety circuits external to the programmable controller to ensure that the entire system operates safely even when a fault occurs in the external power supply or the programmable controller. Failure to do so may result in an accident due to an incorrect output or malfunction.
 - If safety standards (ex., robot safety rules, etc.) apply to the system using the module, servo amplifier and servo motor, make sure that the safety standards are satisfied.
 - Construct a safety circuit externally of the module or servo amplifier if the abnormal operation of the module or servo amplifier differs from the safety directive operation in the system.
 - Do not remove the SSCNETIII cable while turning on the control circuit power supply of modules and servo amplifier. Do not see directly the light generated from SSCNETIII connector of the module or servo amplifier and the end of SSCNETIII cable. When the light gets into eyes, you may feel something wrong with eyes. (The light source of SSCNETIII complies with class 1 defined in JISC6802 or IEC60825-1.)
-

[Design Precautions]

CAUTION

- Do not install the control lines or communication cables together with the main circuit lines or power cables. Keep a distance of 100mm or more between them. Failure to do so may result in malfunction due to noise.
 - During control of an inductive load such as a lamp, heater, or solenoid valve, a large current (approximately ten times greater than normal) may flow when the output is turned from off to on. Therefore, use a module that has a sufficient current rating.
 - After the CPU module is powered on or is reset, the time taken to enter the RUN status varies depending on the system configuration, parameter settings, and/or program size. Design circuits so that the entire system will always operate safely, regardless of the time.
 - Do not power off the programmable controller or reset the CPU module while the settings are being written. Doing so will make the data in the flash ROM and SD memory card undefined. The values need to be set in the buffer memory and written to the flash ROM and SD memory card again. Doing so also may cause malfunction or failure of the module.
 - When changing the operating status of the CPU module from external devices (such as the remote RUN/STOP functions), select "Do Not Open by Program" for "Opening Method" of "Module Parameter". If "Open by Program" is selected, an execution of the remote STOP function causes the communication line to close. Consequently, the CPU module cannot reopen the line, and external devices cannot execute the remote RUN function.
-

[Installation Precautions]

WARNING

- Shut off the external power supply (all phases) used in the system before mounting or removing the module. Failure to do so may result in electric shock or cause the module to fail or malfunction.
-

[Installation Precautions]

CAUTION

- Use the programmable controller in an environment that meets the General Specifications in the Safety Guidelines included with the base unit. Failure to do so may result in electric shock, fire, malfunction, or damage to or deterioration of the product.
 - To mount a module, place the concave part(s) located at the bottom onto the guide(s) of the base unit, and push in the module until the hook(s) located at the top snaps into place. Incorrect interconnection may cause malfunction, failure, or drop of the module.
 - To mount a module with no module fixing hook, place the concave part(s) located at the bottom onto the guide(s) of the base unit, push in the module, and fix it with screw(s). Incorrect interconnection may cause malfunction, failure, or drop of the module.
 - When using the programmable controller in an environment of frequent vibrations, fix the module with a screw.
 - Tighten the screws within the specified torque range. Undertightening can cause drop of the screw, short circuit, or malfunction. Overtightening can damage the screw and/or module, resulting in drop, short circuit, or malfunction.
 - When using an extension cable, connect it to the extension cable connector of the base unit securely. Check the connection for looseness. Poor contact may cause malfunction.
 - When using an SD memory card, fully insert it into the SD memory card slot. Check that it is inserted completely. Poor contact may cause malfunction.
 - Securely insert an extended SRAM cassette into the cassette connector of the CPU module. After insertion, close the cassette cover and check that the cassette is inserted completely. Poor contact may cause malfunction.
 - Do not directly touch any conductive parts and electronic components of the module, SD memory card, extended SRAM cassette, or connector. Doing so may cause malfunction or failure of the module.
-

[Wiring Precautions]

WARNING

- Shut off the external power supply (all phases) used in the system before installation and wiring. Failure to do so may result in electric shock or cause the module to fail or malfunction.
 - After installation and wiring, attach a blank cover module (RG60) to each empty slot and an included extension connector protective cover to the unused extension cable connector before powering on the system for operation. Failure to do so may result in electric shock.
-

[Wiring Precautions]

CAUTION

- Individually ground the FG and LG terminals of the programmable controller with a ground resistance of 100 ohms or less. Failure to do so may result in electric shock or malfunction.
 - For terminal block wiring, use solderless terminals with an insulation sleeve. Do not connect more than two solderless terminals to a terminal.
 - Use applicable solderless terminals and tighten them within the specified torque range. If any spade solderless terminal is used, it may be disconnected when the terminal screw comes loose, resulting in failure.
 - Check the rated voltage and signal layout before wiring to the module, and connect the cables correctly. Connecting a power supply with a different voltage rating or incorrect wiring may cause fire or failure.
 - Connectors for external devices must be crimped or pressed with the tool specified by the manufacturer, or must be correctly soldered. Incomplete connections may cause short circuit, fire, or malfunction.
 - Securely connect the connector to the module. Poor contact may cause malfunction.
 - Do not install the control lines or communication cables together with the main circuit lines or power cables. Keep a distance of 100mm or more between them. Failure to do so may result in malfunction due to noise.
 - When an overcurrent caused by a failure of an external device or a module flows for a long time, it may cause smoke and fire. To prevent this, configure an external safety circuit, such as a fuse.
 - Place the cables in a duct or clamp them. If not, dangling cable may swing or inadvertently be pulled, resulting in damage to the module or cables or malfunction due to poor contact. Do not clamp the extension cables with the jacket stripped. Doing so may change the characteristics of the cables, resulting in malfunction.
 - When disconnecting the communication cable or power cable from the module, do not pull the cable by the cable part. For the cable connected to the terminal block, loosen the terminal screws. Pulling the cable connected to the module may result in malfunction or damage to the module or cable.
 - Check the interface type and correctly connect the cable. Incorrect wiring (connecting the cable to an incorrect interface) may cause failure of the module and external device.
 - Tighten the terminal screws or connector screws within the specified torque range. Undertightening can cause drop of the screw, short circuit, fire, or malfunction. Overtightening can damage the screw and/or module, resulting in drop, short circuit, fire, or malfunction.
 - Tighten the terminal block mounting screws, terminal screws, and module fixing screws within each specified torque range. Undertightening of the terminal block mounting screws and terminal screws can cause short circuit, fire, or malfunction. Overtightening of them can damage the screw and/or module, resulting in drop, short circuit, or malfunction. Undertightening of the module fixing screws can cause drop of the screw. Overtightening of them can damage the screw and/or module, resulting in drop.
 - When disconnecting the cable from the module, do not pull the cable by the cable part. For the cable with connector, hold the connector part of the cable. For the cable connected to the terminal block, loosen the terminal screw. Pulling the cable connected to the module may result in malfunction or damage to the module or cable.
 - Prevent foreign matter such as dust or wire chips from entering the module. Such foreign matter can cause a fire, failure, or malfunction.
-

[Wiring Precautions]

CAUTION

- A protective film is attached to the top of the module to prevent foreign matter, such as wire chips, from entering the module during wiring. Do not remove the film during wiring. Remove it for heat dissipation before system operation.
 - Programmable controllers must be installed in control panels. Connect the main power supply to the power supply module in the control panel through a relay terminal block. Wiring and replacement of a power supply module must be performed by qualified maintenance personnel with knowledge of protection against electric shock. For wiring, refer to the MELSEC iQ-R Module Configuration Manual.
 - For Ethernet cables to be used in the system, select the ones that meet the specifications in the user's manual for the module used. If not, normal data transmission is not guaranteed.
-

[Startup and Maintenance Precautions]

WARNING

- Do not touch any terminal while power is on. Doing so will cause electric shock or malfunction.
 - Correctly connect the battery connector. Do not charge, disassemble, heat, short-circuit, solder, or throw the battery into the fire. Also, do not expose it to liquid or strong shock. Doing so may cause the battery to generate heat, explode, ignite, or leak, resulting in injury or fire.
 - Shut off the external power supply (all phases) used in the system before cleaning the module or retightening the terminal screws, connector screws, or module fixing screws. Failure to do so may result in electric shock.
-

[Startup and Maintenance Precautions]

CAUTION

- When connecting an external device with a CPU module or intelligent function module to modify data of a running programmable controller, configure an interlock circuit in the program to ensure that the entire system will always operate safely. For other forms of control (such as program modification, parameter change, forced output, or operating status change) of a running programmable controller, read the relevant manuals carefully and ensure that the operation is safe before proceeding. Improper operation may damage machines or cause accidents.
 - Especially, when a remote programmable controller is controlled by an external device, immediate action cannot be taken if a problem occurs in the programmable controller due to a communication failure. To prevent this, configure an interlock circuit in the program, and determine corrective actions to be taken between the external device and CPU module in case of a communication failure.
 - Do not disassemble or modify the modules. Doing so may cause failure, malfunction, injury, or a fire.
 - Use any radio communication device such as a cellular phone or PHS (Personal Handy-phone System) more than 25cm away in all directions from the programmable controller. Failure to do so may cause malfunction.
 - Shut off the external power supply (all phases) used in the system before mounting or removing the module. Failure to do so may cause the module to fail or malfunction.
 - Tighten the screws within the specified torque range. Undertightening can cause drop of the component or wire, short circuit, or malfunction. Overtightening can damage the screw and/or module, resulting in drop, short circuit, or malfunction.
-

[Startup and Maintenance Precautions]

CAUTION

- After the first use of the product, do not mount/remove the module to/from the base unit, and the terminal block to/from the module, and do not insert/remove the extended SRAM cassette to/from the CPU module more than 50 times (IEC 61131-2 compliant) respectively. Exceeding the limit of 50 times may cause malfunction.
 - After the first use of the product, do not insert/remove the SD memory card to/from the CPU module more than 500 times. Exceeding the limit of 500 times may cause malfunction.
 - Do not touch the metal terminals on the back side of the SD memory card. Doing so may cause malfunction or failure.
 - Do not touch the integrated circuits on the circuit board of an extended SRAM cassette. Doing so may cause malfunction or failure.
 - Do not drop or apply shock to the battery to be installed in the module. Doing so may damage the battery, causing the battery fluid to leak inside the battery. If the battery is dropped or any shock is applied to it, dispose of it without using.
 - Startup and maintenance of a control panel must be performed by qualified maintenance personnel with knowledge of protection against electric shock. Lock the control panel so that only qualified maintenance personnel can operate it.
 - Before handling the module, touch a conducting object such as a grounded metal to discharge the static electricity from the human body. Failure to do so may cause the module to fail or malfunction.
 - Before testing the operation, set a low speed value for the speed limit parameter so that the operation can be stopped immediately upon occurrence of a hazardous condition.
 - Confirm and adjust the program and each parameter before operation. Unpredictable movements may occur depending on the machine.
 - When using the absolute position system function, on starting up, and when the module or absolute position motor has been replaced, always perform a home position return.
 - Before starting the operation, confirm the brake function.
 - Do not perform a megger test (insulation resistance measurement) during inspection.
 - After maintenance and inspections are completed, confirm that the position detection of the absolute position detection function is correct.
 - Lock the control panel and prevent access to those who are not certified to handle or install electric equipment.
-

[Operating Precautions]

CAUTION

- When changing data and operating status, and modifying program of the running programmable controller from an external device such as a personal computer connected to an intelligent function module, read relevant manuals carefully and ensure the safety before operation. Incorrect change or modification may cause system malfunction, damage to the machines, or accidents.
 - Do not power off the programmable controller or reset the CPU module while the setting values in the buffer memory are being written to the flash ROM in the module. Doing so will make the data in the flash ROM and SD memory card undefined. The values need to be set in the buffer memory and written to the flash ROM and SD memory card again. Doing so also may cause malfunction or failure of the module.
 - Note that when the reference axis speed is specified for interpolation operation, the speed of the partner axis (2nd, 3rd, or 4th axis) may exceed the speed limit value.
 - Do not go near the machine during test operations or during operations such as teaching. Doing so may lead to injuries.
-

[Disposal Precautions]

CAUTION

- When disposing of this product, treat it as industrial waste.
 - When disposing of batteries, separate them from other wastes according to the local regulations. For details on battery regulations in EU member states, refer to the MELSEC iQ-R Module Configuration Manual.
-

[Transportation Precautions]

CAUTION

- When transporting lithium batteries, follow the transportation regulations. For details on the regulated models, refer to the MELSEC iQ-R Module Configuration Manual.
 - The halogens (such as fluorine, chlorine, bromine, and iodine), which are contained in a fumigant used for disinfection and pest control of wood packaging materials, may cause failure of the product. Prevent the entry of fumigant residues into the product or consider other methods (such as heat treatment) instead of fumigation. The disinfection and pest control measures must be applied to unprocessed raw wood.
-

CONDITIONS OF USE FOR THE PRODUCT

(1) Mitsubishi programmable controller ("the PRODUCT") shall be used in conditions;

- i) where any problem, fault or failure occurring in the PRODUCT, if any, shall not lead to any major or serious accident; and
- ii) where the backup and fail-safe function are systematically or automatically provided outside of the PRODUCT for the case of any problem, fault or failure occurring in the PRODUCT.

(2) The PRODUCT has been designed and manufactured for the purpose of being used in general industries.

MITSUBISHI SHALL HAVE NO RESPONSIBILITY OR LIABILITY (INCLUDING, BUT NOT LIMITED TO ANY AND ALL RESPONSIBILITY OR LIABILITY BASED ON CONTRACT, WARRANTY, TORT, PRODUCT LIABILITY) FOR ANY INJURY OR DEATH TO PERSONS OR LOSS OR DAMAGE TO PROPERTY CAUSED BY the PRODUCT THAT ARE OPERATED OR USED IN APPLICATION NOT INTENDED OR EXCLUDED BY INSTRUCTIONS, PRECAUTIONS, OR WARNING CONTAINED IN MITSUBISHI'S USER, INSTRUCTION AND/OR SAFETY MANUALS, TECHNICAL BULLETINS AND GUIDELINES FOR the PRODUCT.

("Prohibited Application")

Prohibited Applications include, but not limited to, the use of the PRODUCT in;

- Nuclear Power Plants and any other power plants operated by Power companies, and/or any other cases in which the public could be affected if any problem or fault occurs in the PRODUCT.
- Railway companies or Public service purposes, and/or any other cases in which establishment of a special quality assurance system is required by the Purchaser or End User.
- Aircraft or Aerospace, Medical applications, Train equipment, transport equipment such as Elevator and Escalator, Incineration and Fuel devices, Vehicles, Manned transportation, Equipment for Recreation and Amusement, and Safety devices, handling of Nuclear or Hazardous Materials or Chemicals, Mining and Drilling, and/or other applications where there is a significant risk of injury to the public or property.

Notwithstanding the above, restrictions Mitsubishi may in its sole discretion, authorize use of the PRODUCT in one or more of the Prohibited Applications, provided that the usage of the PRODUCT is limited only for the specific applications agreed to by Mitsubishi and provided further that no special quality assurance or fail-safe, redundant or other safety features which exceed the general specifications of the PRODUCTS are required. For details, please contact the Mitsubishi representative in your region.

INTRODUCTION

Thank you for purchasing the Mitsubishi Electric MELSEC iQ-R series programmable controllers.

This manual describes the commands and programs for the programming of the relevant products listed below.

Before using this product, please read this manual and the relevant manuals carefully and develop familiarity with the functions and performance of the MELSEC iQ-R series programmable controller to handle the product correctly.

When applying the program examples provided in this manual to an actual system, ensure the applicability and confirm that it will not cause system control problems.

Please make sure that the end users read this manual.

Relevant products

R16MTCPU, R32MTCPU, R64MTCPU

CONTENTS

SAFETY PRECAUTIONS	1
CONDITIONS OF USE FOR THE PRODUCT	9
INTRODUCTION	9
RELEVANT MANUALS	15
TERMS	16
MANUAL PAGE ORGANIZATION	17
CHAPTER 1 OVERVIEW	20
1.1 Performance Specifications	20
Motion SFC performance specifications	20
Operation control/transition control specifications	21
1.2 Structure of the Motion CPU Program	29
CHAPTER 2 MOTION DEDICATED PLC INSTRUCTION	30
2.1 Outline of Motion Dedicated PLC Instruction	30
2.2 Motion Dedicated PLC Instruction	31
Motion SFC start request from the PLC CPU to the Motion CPU: M(P).SFCS/D(P).SFCS	32
Servo program start request from the PLC CPU to the Motion CPU: M(P).SVST/D(P).SVST	35
Direct positioning start instruction from the PLC CPU to the Motion CPU: M(P).SVSTD/D(P).SVSTD	40
Current value change instruction from the PLC CPU to the Motion CPU: M(P).CHGA/D(P).CHGA	52
Current value change instruction of command generation axis from the PLC CPU to the Motion CPU: M(P).CHGAS/D(P).CHGAS	56
Speed change instruction from the PLC CPU to the Motion CPU: M(P).CHGV/D(P).CHGV	60
Speed change instruction of command generation axis from the PLC CPU to the Motion CPU: M(P).CHGVS/D(P).CHGVS	65
Torque limit value change request instruction from the PLC CPU to the Motion CPU: M(P).CHGT/D(P).CHGT	70
Machine program operation start request from the PLC CPU to the Motion CPU: M(P).MCNST/D(P).MCNST	73
Write bit device to the Motion CPU: M(P).BITWR/D(P).BITWR	77
Interrupt instruction to the other CPU: M(P).GINT/D(P).GINT	80
2.3 Precautions	83
CPU buffer memory address used in Motion dedicated instruction	83
Number of blocks used for Motion dedicated PLC instruction	85
Execution of Motion dedicated PLC instruction	89
Complete status information	90
Order of instruction execution	91
CHAPTER 3 MOTION SFC PROGRAMS	93
3.1 Motion SFC Program Configuration	93
3.2 Motion SFC Chart Symbol List	94
3.3 Branch and Coupling Chart List	96
3.4 Motion SFC Program Name	99
3.5 Steps	100
Motion control step	100
Operation control step	101
Subroutine call/start step	102
Clear step	103
3.6 Transitions	104
3.7 Jump, Pointer	106

3.8	END	107
3.9	Branches, Couplings	108
	Series transition	108
	Selective branch, selective coupling	109
	Parallel branch, parallel coupling	110
3.10	Y/N Transitions	112
3.11	Motion SFC Comments	116
CHAPTER 4 OPERATION CONTROL PROGRAMS		118
4.1	Operation Control Programs	118
4.2	Device Descriptions	123
4.3	Constant Descriptions	126
4.4	Labels	127
	Types	127
	Data types	127
	Arrays	128
	Structures	129
	Precautions	131
4.5	Binary Operations	132
	Substitution: =	132
	Addition: +	134
	Subtraction: -	135
	Multiplication: *	136
	Division: /	137
	Remainder: %	138
4.6	Bit Operations	139
	Bit inversion (Complement): ~	139
	Bit logical AND: &	140
	Bit logical OR: 	141
	Bit exclusive logical OR: ^	142
	Bit right shift: >>	143
	Bit left shift: <<	144
	Sign inversion (Complement of 2): -	145
4.7	Standard Functions	146
	Sine: SIN	146
	Cosine: COS	147
	Tangent: TAN	148
	Arcsine: ASIN	149
	Arccosine: ACOS	150
	Arctangent: ATAN	151
	Square root: SQRT	152
	Natural logarithm: LN	153
	Exponential operation: EXP	154
	Absolute value: ABS	155
	Round-off: RND	156
	Round-down: FIX	157
	Round-up: FUP	158
	BCD -> BIN conversion: BIN	159
	BIN -> BCD conversion: BCD	160
4.8	Data Control	161

	16-bit integer type scaling: SCL	161
	32-bit integer type scaling: DSCL	165
4.9	Type Conversions	168
	Signed 16-bit integer value conversion: SHORT	168
	Unsigned 16-bit integer value conversion: USHORT	169
	Signed 32-bit integer value conversion: LONG	171
	Unsigned 32-bit integer value conversion: ULONG	172
	Signed 64-bit floating-point value conversion: FLOAT	174
	Unsigned 64-bit floating-point value conversion: UFLOAT	175
	Floating-point value conversion 32-bit into 64-bit: DFLT	176
	Floating-point value conversion 64-bit into 32-bit: SFLT	177
4.10	Bit Device Statuses	178
	ON (Normally open contact): (None)	178
	OFF (Normally closed contact): !	179
4.11	Bit Device Controls	180
	Device set: SET	180
	Device reset: RST	181
	Device output: DOUT	182
	Device input: DIN	183
	Bit device output: OUT	184
4.12	Logical Operations	185
	Logical acknowledgement: (None)	185
	Logical negation: !	186
	Logical AND: *	187
	Logical OR: +	188
4.13	Comparison Operations	189
	Equal to: ==	189
	Not equal to: !=	190
	Less than: <	191
	Less than or equal to: <=	192
	More than: >	193
	More than or equal to: >=	194
4.14	Program Control	195
	Conditional branch control: IF - ELSE - IEND	195
	Selective branch control: SELECT - CASE - SEND	197
	Repeat control with specified count: FOR - NEXT	199
	Forced termination of repeat control: BREAK	201
4.15	Motion-Dedicated Functions	202
	Speed change request: CHGV	202
	Command generation axis speed change request: CHGVS	206
	Torque limit value change request: CHGT	210
	Target position change request: CHGP	212
	Machine program operation start request: MCNST	220
4.16	Advanced Synchronous Control Dedicated Function	222
	Cam data read: CAMRD	222
	Cam data write: CAMWR	227
	Cam auto-generation: CAMMK	231
	Cam position calculation: CAMPSCL	243
4.17	Vision System Dedicated Function	246
	Open line: MVOPEN	246
	Load a program: MVLOAD	247

Send an image acquisition trigger: MVTRG	248
Start a program: MVPST	249
Input data: MVIN	251
Output data: MVOUT	253
Reset a status storage device: MVFIN	255
Close line: MVCLOSE	256
Send a command for native mode: MVCOM	257
4.18 Add-on Dedicated Function	260
Call add-on module: MCFUN	260
4.19 Other Instructions	262
Event task enable: EI	262
Event task disable: DI	263
No operation: NOP	264
Block transfer: BMOV	265
Same data block transfer: FMOV	267
Write device data to buffer memory: TO	269
Read device data from buffer memory: FROM	271
Write buffer memory data to head module: RTO	274
Read buffer memory data from head module: RFROM	277
Time to wait: TIME	280
4.20 Comment Statement: //	282
CHAPTER 5 TRANSITION PROGRAMS	283
<hr/>	
5.1 Transition Programs	283
CHAPTER 6 OPERATION FOR MOTION SFC AND PARAMETER	285
<hr/>	
6.1 Task Definitions	285
6.2 Number of Consecutive Transitions and Task Operation	285
Number of consecutive transitions	285
Task operation	286
6.3 Execution Status of the Multiple Task	289
6.4 How to Start the Motion SFC Program	291
Automatic start	291
Start from the Motion SFC program	291
Start from the Motion dedicated PLC instruction of other CPU (PLC instruction: M(P).SFCS/D(P).SFCS)	291
6.5 How to End the Motion SFC Program	292
6.6 How to Change from One Motion SFC Program to Another	292
6.7 Operation Performed at Multiple CPU System Power-Off or Reset	292
6.8 Task Parameters	293
6.9 Program Parameters	295
6.10 Task and Interrupt Processing	299
CHAPTER 7 MOTION SFC FUNCTIONS	301
<hr/>	
7.1 Online Change in the Motion SFC Program	301
Operating method for the online change	302
Reading/Writing of program	305
7.2 Motion SFC Program Monitor and Debug Mode	307
Motion SFC program monitor	307
Debug mode	307

APPENDICES

308

Appendix 1 Processing Times	308
Processing time of operation control/Transition instruction	308
Processing time of advanced synchronous control dedicated functions	332
Deploying time for cam data	334
Processing time of Motion dedicated PLC instruction	335
Appendix 2 Sample Program	336
Motion control example by Motion SFC program	336
Continuation execution example at the subroutine re-start by the Motion SFC program	343
Continuation execution example after the stop by the Motion SFC program	346
REVISIONS	350
WARRANTY	351
TRADEMARKS	352

RELEVANT MANUALS

Manual Name [Manual Number]	Description	Available form
MELSEC iQ-R Motion Controller Programming Manual (Program Design) [IB-0300239] (This manual)	This manual explains the functions, programming, debugging for Motion SFC and others.	Print book e-Manual PDF
MELSEC iQ-R Motion Controller User's Manual [IB-0300235]	This manual explains specifications of the Motion CPU modules, SSCNETIII cables, synchronous encoder, troubleshooting, and others.	Print book e-Manual PDF
MELSEC iQ-R Motion Controller Programming Manual (Common) [IB-0300237]	This manual explains the Multiple CPU system configuration, performance specifications, common parameters, auxiliary/applied functions, error lists and others.	Print book e-Manual PDF
MELSEC iQ-R Motion Controller Programming Manual (Positioning Control) [IB-0300241]	This manual explains the servo parameters, positioning instructions, device lists and others.	Print book e-Manual PDF
MELSEC iQ-R Motion Controller Programming Manual (Advanced Synchronous Control) [IB-0300243]	This manual explains the dedicated instructions to use synchronous control by synchronous control parameters, device lists and others.	Print book e-Manual PDF
MELSEC iQ-R Motion Controller Programming Manual (Machine Control) [IB-0300309]	This manual explains the dedicated instructions to use machine control by machine control parameters, machine positioning data, device lists and others.	Print book e-Manual PDF
MELSEC iQ-R Motion Controller Programming Manual (G-Code Control) [IB-0300371]	This manual explains the dedicated instructions to use G-code control by G-code control parameters and G-code programs.	Print book e-Manual PDF



e-Manual refers to the Mitsubishi FA electronic book manuals that can be browsed using a dedicated tool.

e-Manual has the following features:

- Required information can be cross-searched in multiple manuals.
- Other manuals can be accessed from the links in the manual.
- The hardware specifications of each part can be found from the product figures.
- Pages that users often browse can be bookmarked.

TERMS

Unless otherwise specified, this manual uses the following terms.

Term	Description
R64MTCPU/R32MTCPU/R16MTCPU or Motion CPU (module)	Abbreviation for MELSEC iQ-R series Motion controller
MR-J4(W)-□B	Servo amplifier model MR-J4-□B/MR-J4W-□B
MR-J3(W)-□B	Servo amplifier model MR-J3-□B/MR-J3W-□B
AMP or Servo amplifier	General name for "Servo amplifier model MR-J4-□B/MR-J4W-□B/MR-J3-□B/MR-J3W-□B"
RnCPU, PLC CPU or PLC CPU module	Abbreviation for MELSEC iQ-R series CPU module
Multiple CPU system or Motion system	Abbreviation for "Multiple PLC system of the R series"
CPU _n	Abbreviation for "CPU No.n (n = 1 to 4) of the CPU module for the Multiple CPU system"
Operating system software	General name for "SW10DNC-RMTFW"
Engineering software package	General name for MT Developer2/GX Works3
MELSOFT MT Works2	General product name for the Motion controller engineering software "SW1DND-MTW2"
MT Developer2	Abbreviation for the programming software included in the "MELSOFT MT Works2" Motion controller engineering software
GX Works3	General product name for the MELSEC PLC software package "SW1DND-GXW3"
Serial absolute synchronous encoder or Q171ENC-W8	Abbreviation for "Serial absolute synchronous encoder (Q171ENC-W8)"
SSCNETⅢ/H ^{*1}	High speed synchronous network between Motion controller and servo amplifier
SSCNETⅢ ^{*1}	
SSCNETⅢ(H)	General name for SSCNETⅢ/H, SSCNETⅢ
Absolute position system	General name for "system using the servomotor and servo amplifier for absolute position"
Intelligent function module	General name for module that has a function other than input or output such as A/D converter module and D/A converter module.
SSCNETⅢ/H head module ^{*1}	Abbreviation for "MELSEC-L series SSCNETⅢ/H head module (LJ72MS15)"
Optical hub unit or MR-MV200	Abbreviation for SSCNETⅢ/H Compatible Optical Hub Unit (MR-MV200)
Sensing module	General name for SSCNETⅢ/H compatible sensing module MR-MT2000 series
Sensing SSCNETⅢ/H head module ^{*1} or MR-MT2010	Abbreviation for SSCNETⅢ/H head module (MR-MT2010)
Sensing extension module	General name for I/O module (MR-MT2100), pulse I/O module (MR-MT2200), analog I/O module (MR-MT2300), encoder I/F module (MR-MT2400)
Sensing I/O module or MR-MT2100	Abbreviation for I/O module (MR-MT2100)
Sensing pulse I/O module or MR-MT2200	Abbreviation for pulse I/O module (MR-MT2200)
Sensing analog I/O module or MR-MT2300	Abbreviation for analog I/O module (MR-MT2300)
Sensing encoder I/F module or MR-MT2400	Abbreviation for encoder I/F module (MR-MT2400)

*1 SSCNET: Servo System Controller NETwork

MANUAL PAGE ORGANIZATION

Representation of numerical values used in this manual

■Axis No. representation

In the positioning dedicated signals, "n" in "M3200+20n", etc. indicates a value corresponding to axis No. as shown in the following table.

Axis No.	n	Axis No.	n	Axis No.	n	Axis No.	n	Axis No.	n	Axis No.	n	Axis No.	n	Axis No.	n
1	0	9	8	17	16	25	24	33	32	41	40	49	48	57	56
2	1	10	9	18	17	26	25	34	33	42	41	50	49	58	57
3	2	11	10	19	18	27	26	35	34	43	42	51	50	59	58
4	3	12	11	20	19	28	27	36	35	44	43	52	51	60	59
5	4	13	12	21	20	29	28	37	36	45	44	53	52	61	60
6	5	14	13	22	21	30	29	38	37	46	45	54	53	62	61
7	6	15	14	23	22	31	30	39	38	47	46	55	54	63	62
8	7	16	15	24	23	32	31	40	39	48	47	56	55	64	63

- The range of axis No.1 to 16 (n=0 to 15) is valid in the R16MTCPU. The range of axis No.1 to 32 (n=0 to 31) is valid in the R32MTCPU.
- Calculate as follows for the device No. corresponding to each axis.

Ex.

For axis No. 32 in Q series Motion compatible device assignment

M3200+20n ([Rq.1140] Stop command)=M3200+20×31=M3820

M3215+20n ([Rq.1155] Servo OFF command)=M3215+20×31=M3835

In the positioning dedicated signals, "n" in "M10440+10n", etc. of the "Synchronous encoder axis status", "Synchronous encoder axis command signal", "Synchronous encoder axis monitor device" and "Synchronous encoder axis control device" indicates a value corresponding to synchronous encoder axis No. as shown in the following table.

Synchronous encoder axis No.	n	Synchronous encoder axis No.	n	Synchronous encoder axis No.	n
1	0	5	4	9	8
2	1	6	5	10	9
3	2	7	6	11	10
4	3	8	7	12	11

- Calculate as follows for the device No. corresponding to each synchronous encoder.

Ex.

For synchronous encoder axis No.12 in Q series Motion compatible device assignment

M10440+10n ([St.320] Synchronous encoder axis setting valid flag)=M10440+10×11=M10550

D13240+20n ([Md.320] Synchronous encoder axis current value)=D13240+20×11=D13460

■Machine No. representation

In the positioning dedicated signals, "m" in "M43904+32m", etc. indicates a value corresponding to machine No. as shown in the following table.

Machine No.	m	Machine No.	m
1	0	5	4
2	1	6	5
3	2	7	6
4	3	8	7

- Calculate as follows for the device No. corresponding to each machine.

Ex.

For machine No.8 in MELSEC iQ-R Motion device assignment

M43904+32m ([St.2120] Machine error detection) $M43904+32 \times 7 = M44128$

D53168+128m ([Md.2020] Machine type) $= M53168+28 \times 7 = D54064$

■Line No. representation in G-code control

In the positioning dedicated signals, "s" in "D54496+128s", etc. indicates a value corresponding to line No. as shown in the following table.

Line No.	s
1	0
2	1

- Calculate as follows for the device No. corresponding to each line.

Ex.

For line No.2 in MELSEC iQ-R Motion device assignment

D54440.0+4s ([St.3208] During G-code control) $= D54440.0+4 \times 1 = D54444.0$

D54496+128s ([Md.3016] Number of axes on line) $= D54496+128 \times 1 = D54624$

■Line No. and axis No. representation in G-code control

In the positioning dedicated signals, "sn" in "D54278+16sn", etc. indicates a value corresponding to line No. and axis No. as shown in the following table.

Line No.	Axis No.	sn	Line No.	Axis No.	sn
1	1	0	2	1	8
	2	1		2	9
	3	2		3	10
	4	3		4	11
	5	4		5	12
	6	5		6	13
	7	6		7	14
	8	7		8	15

- Calculate as follows for the device No. corresponding to each line.

Ex.

For line No.2, axis No. 8 in MELSEC iQ-R Motion device assignment

D54448.0+2sn ([St.3076] Smoothing zero) $= D54448.0+2 \times 15 = D54478.0$

D54754+32sn ([Md.3146] Rotating axis setting status) $= D54754+32 \times 15 = D55234$

Representation of device No. used in this manual

The "R" and "Q" beside the device No. of positioning dedicated signals such as "[Rq.1140] Stop command (R: M34480+32n/ Q: M3200+20n)" indicate the device No. for the device assignment methods shown below. When "R" and "Q" are not beside the device No., the device No. is the same for both device assignment methods.

Symbol	Device assignment method
R	MELSEC iQ-R Motion device assignment
Q	Q series Motion compatible device assignment

1 OVERVIEW

1.1 Performance Specifications

Motion SFC performance specifications

Item		R64MTCPU/R32MTCPU/R16MTCPU			
Motion SFC program capacity	Code total (Motion SFC chart + Operation control + Transition)	8192k bytes ^{*1}			
Motion SFC program	Number of Motion SFC programs	512 (No.0 to 511) ^{*2}			
	Motion SFC chart size/program	Up to 64k bytes (Included Motion SFC chart comments)			
	Number of Motion SFC steps/program	Up to 4094 steps			
	Number of selective branches/branch	255			
	Number of parallel branches/branch	255			
	Parallel branch nesting	Up to 4 levels			
Operation control program (F/FS)/ Transition program (G)	Number of operation control programs	4096 with F(Once execution type) and FS(Scan execution type) combined. (F/FS0 to F/FS4095)			
	Number of transition programs	4096(G0 to G4095)			
	Code size/program	Up to approx. 128k bytes (65534 steps)			
	Number of blocks(line)/program	Up to 8192 blocks (in the case of 8 steps(min)/blocks)			
	Number of characters/block	Up to 1020 (comment included)			
	Number of operand/block	Up to 510 (operand: constants, word device, bit devices)			
	() nesting/block	Up to 32 levels			
	Descriptive expression	<table border="1"> <tr> <td>Operation control program</td> <td>Calculation expression, bit conditional expression, branch/repetition processing</td> </tr> <tr> <td>Transition program</td> <td>Calculation expression/bit conditional expression/comparison conditional expression</td> </tr> </table>	Operation control program	Calculation expression, bit conditional expression, branch/repetition processing	Transition program
Operation control program	Calculation expression, bit conditional expression, branch/repetition processing				
Transition program	Calculation expression/bit conditional expression/comparison conditional expression				
Execute specification	Number of multi execute programs	Up to 512 ^{*3}			
	Number of multi active steps	Up to 1024 steps ^{*4} /all programs			
	Executed task	Normal task	Execute in main cycle of Motion CPU		
		Event task (Execution can be masked.)	Fixed cycle	Execute in fixed cycle (0.222ms, 0.444ms, 0.888ms, 1.777ms, 3.555ms, 7.111ms, 14.222ms)	
			External interrupt	Executes when the input set to the event task factor in the input module controlled by the Motion CPU (16 points) turns ON.	
			PLC interrupt	Execute with interrupt instruction (M(P).GINT/D(P).GINT) from PLC CPU.	
NMI task	Executes when the input set to the NMI task factor in the input module controlled by the Motion CPU (16 points) turns ON.				

*1 For operating system software version "09" or earlier, 4096k bytes.

*2 For operating system software version "09" or earlier, 256 (No.0 to 255).

*3 For operating system software version "09" or earlier, up to 256.

*4 For operating system software version "08" or earlier, up to 256 steps.

Operation control/transition control specifications

Table of the operation control/transition control specifications

■Expression

Specifications		Remark
Calculation expression	Returns a numeric result. Expressions for calculating indirectly specified data using constants and word devices.	D100+1, SIN(D100), etc.
Conditional expression	Bit conditional expression	Returns a true or false result. Expression for judging ON or OFF of bit device.
	Comparison conditional expression	Expressions for comparing indirectly specified data and calculation expressions using constants and word devices.
		M0, !M0, M1*M0, (M1+M2)*(!M3+M4), etc.
		D100==100 D10<D102+D10, etc.

■Bit devices

○: Usable, ×: Unusable

Device	Symbol	Accessibility		Usable tasks			Description example
		Read	Write	Normal	Event	NMI	
Input	X	○	○	○	○	○	X100
Output	Y	○	○				Y100
Internal relay	M	○	○				M20
Link relay	B	○	○				B3FF
Annunciator	F	○	○				F0
Data register	D	○	○				D0.A
Link register	W	○	○				W1F.A
Motion register	#	○	○				#0.A
Special relay	SM	○	○				SM0
Special register	SD	○	○				SD0.A
CPU buffer memory access device	U3E□\G	○	○				U3E0\G200.A
CPU buffer memory access device (fixed scan communication area)	U3E□\HG	○	○				U3E0\HG200.A
Module access device	U□\G	○	○				U0\G10200.A

Restriction

Restrictions on write-enabled bit devices

- Write to device X is allowed only in a device other than the actual input device.
- Special register, special relay has predetermined applications in the system. Do not perform write to other than the user setting device.

■Word devices

○: Usable, ×: Unusable

Devices	Symbol	Accessibility		Usable tasks			Description example
		Read	Write	Normal	Event	NMI	
Data register	D	○	○	○	○	○	D0L
Link register	W	○	○				W1F:F
Motion register	#	○	○				#0F
Special register	SD	○	○				SD0
CPU buffer memory access device	U3E□\G	○	○				U3E0\G100L
CPU buffer memory access device (fixed scan communication area)	U3E□\HG	○	○				U3E0\HG100L
Module access device	U□\G	○	○				U0\G10100L

Restriction

Restrictions on write-enabled word devices

- Special register has predetermined applications in the system. Do not perform write to other than the user-set device.

■Data type

Specifications			Remark
(None)	16-bit integer type (signed)	-32768 to 32767	K10, D100, etc.
	16-bit integer type (unsigned)	0 to 65535	
L	32-bit integer type (signed)	-2147483648 to 2147483647	2000000000, W100L, etc.
	32-bit integer type (unsigned)	0 to 4294967295	
F	64-bit floating-point type (double precision real number type)	IEEE format	1.23, #10F, etc.

■Constant

Specifications			Remark
K	Decimal constant	The above data type symbol 'L' or '.' (decimal point) provided at the end indicates the data type. The constant without the data type is regarded as the applicable minimum type.	K-100, H0FFL, etc. 'K' may be omitted.
H	Hexadecimal constant		

■Read/write response of input, output

Specifications		Remark
Input response	Direct read control at instruction execution.	
Output response	Direct write control at instruction execution.	

Table of the operation control/transition instruction

○: Usable, —: Unusable

Classification	Symbol	Function	Format	Basic steps	Usable step		Y/N transition's conditional expression	Section of reference
					F/FS	G		
Binary operation	=	Substitution	(D)=(S)	8	○	○	—	Page 132 Substitution: =
	+	Addition	(S1)+(S2)	7	○	○	—	Page 134 Addition: +
	-	Subtraction	(S1)-(S2)	7	○	○	—	Page 135 Subtraction: -
	*	Multiplication	(S1)*(S2)	7	○	○	—	Page 136 Multiplication: *
	/	Division	(S1)/(S2)	7	○	○	—	Page 137 Division: /
	%	Remainder	(S1)%(S2)	7	○	○	—	Page 138 Remainder: %
Bit operation	~	Bit inversion (complement)	~(S)	4	○	○	—	Page 139 Bit inversion (Complement): ~
	&	Bit logical AND	(S1)&(S2)	7	○	○	—	Page 140 Bit logical AND: &
		Bit logical OR	(S1) (S2)	7	○	○	—	Page 141 Bit logical OR:
	^	Bit exclusive logical OR	(S1)^(S2)	7	○	○	—	Page 142 Bit exclusive logical OR: ^
	>>	Bit right shift	(S1)>>(S2)	7	○	○	—	Page 143 Bit right shift: >>
	<<	Bit left shift	(S1)<<(S2)	7	○	○	—	Page 144 Bit left shift: <<
Sign	-	Sign inversion (complement of 2)	-(S)	4	○	○	—	Page 145 Sign inversion (Complement of 2): -

Classification	Symbol	Function	Format	Basic steps	Usable step		Y/N transition's conditional expression	Section of reference
					F/FS	G		
Standard function	SIN	Sine	SIN(S)	4	<input type="radio"/>	<input type="radio"/>	—	☞ Page 146 Sine: SIN
	COS	Cosine	COS(S)	4	<input type="radio"/>	<input type="radio"/>	—	☞ Page 147 Cosine: COS
	TAN	Tangent	TAN(S)	4	<input type="radio"/>	<input type="radio"/>	—	☞ Page 148 Tangent: TAN
	ASIN	Arcsine	ASIN(S)	4	<input type="radio"/>	<input type="radio"/>	—	☞ Page 149 Arcsine: ASIN
	ACOS	Arccosine	ACOS(S)	4	<input type="radio"/>	<input type="radio"/>	—	☞ Page 150 Arccosine: ACOS
	ATAN	Arctangent	ATAN(S)	4	<input type="radio"/>	<input type="radio"/>	—	☞ Page 151 Arctangent: ATAN
	SQRT	Square root	SQRT(S)	4	<input type="radio"/>	<input type="radio"/>	—	☞ Page 152 Square root: SQRT
	LN	Natural logarithm	LN(S)	4	<input type="radio"/>	<input type="radio"/>	—	☞ Page 153 Natural logarithm: LN
	EXP	Exponential operation	EXP(S)	4	<input type="radio"/>	<input type="radio"/>	—	☞ Page 154 Exponential operation: EXP
	ABS	Absolute value	ABS(S)	4	<input type="radio"/>	<input type="radio"/>	—	☞ Page 155 Absolute value: ABS
	RND	Round-off	RND(S)	4	<input type="radio"/>	<input type="radio"/>	—	☞ Page 156 Round-off: RND
	FIX	Round-down	FIX(S)	4	<input type="radio"/>	<input type="radio"/>	—	☞ Page 157 Round-down: FIX
	FUP	Round-up	FUP(S)	4	<input type="radio"/>	<input type="radio"/>	—	☞ Page 158 Round-up: FUP
	BIN	BCD→BIN conversion	BIN(S)	4	<input type="radio"/>	<input type="radio"/>	—	☞ Page 159 BCD -> BIN conversion: BIN
BCD	BIN→BCD conversion	BCD(S)	4	<input type="radio"/>	<input type="radio"/>	—	☞ Page 160 BIN -> BCD conversion: BCD	
Data control	SCL	16-bit integer type scaling	SCL(S1),(S2),(S3),(D)	15	<input type="radio"/>	<input type="radio"/>	—	☞ Page 161 16-bit integer type scaling: SCL
	DSCL	32-bit integer type scaling	DSCL(S1),(S2),(S3),(D)	15	<input type="radio"/>	<input type="radio"/>	—	☞ Page 165 32-bit integer type scaling: DSCL

Classification	Symbol	Function	Format	Basic steps	Usable step		Y/N transition's conditional expression	Section of reference
					F/FS	G		
Type conversion	SHORT	Convert into 16-bit integer type (signed)	SHORT(S)	4	○	○	—	☞ Page 168 Signed 16-bit integer value conversion: SHORT
	USHORT	Convert into 16-bit integer type (unsigned)	USHORT(S)	4	○	○	—	☞ Page 169 Unsigned 16-bit integer value conversion: USHORT
	LONG	Convert into 32-bit integer type (signed)	LONG(S)	4	○	○	—	☞ Page 171 Signed 32-bit integer value conversion: LONG
	ULONG	Convert into 32-bit integer type (unsigned)	ULONG(S)	4	○	○	—	☞ Page 172 Unsigned 32-bit integer value conversion: ULONG
	FLOAT	Regard as signed data and convert into 64-bit floating point type	FLOAT(S)	4	○	○	—	☞ Page 174 Signed 64-bit floating-point value conversion: FLOAT
	UFLOAT	Regard as unsigned data and convert into 64-bit floating point type	UFLOAT(S)	4	○	○	—	☞ Page 175 Unsigned 64-bit floating-point value conversion: UFLOAT
	DFLT	Floating-point value conversion 32-bit into 64-bit	DFLT(S)	4	○	○	—	☞ Page 176 Floating-point value conversion 32-bit into 64-bit: DFLT
	SFLT	Floating-point value conversion 64-bit into 32-bit	SFLT(S)	4	○	○	—	☞ Page 177 Floating-point value conversion 64-bit into 32-bit: SFLT
Bit device status	(None)	ON (normally open contact)	(S)	4	○	○	○	☞ Page 178 ON (Normally open contact): (None)
	!	OFF (normally closed contact)	!(S)	4	○	○	○	☞ Page 179 OFF (Normally closed contact): !
Bit device control	SET	Device set	SET(D)	5	○	○	—	☞ Page 180 Device set: SET
			SET(D)=(conditional expression)	8	○	○	—	
	RST	Device reset	RST(D)	5	○	○	—	☞ Page 181 Device reset: RST
			RST(D)=(conditional expression)	8	○	○	—	
	DOUT	Device output	DOUT(D),(S)	8	○	○	—	☞ Page 182 Device output: DOUT
	DIN	Device input	DIN(D),(S)	8	○	○	—	☞ Page 183 Device input: DIN
OUT	Bit device output	OUT(D)=(conditional expression)	8	○	○	—	☞ Page 184 Bit device output: OUT	

Classification	Symbol	Function	Format	Basic steps	Usable step		Y/N transition's conditional expression	Section of reference
					F/FS	G		
Logical operation	(None)	Logical acknowledgment	(Conditional expression)	0	<input type="radio"/>	<input type="radio"/>	<input type="radio"/>	☞ Page 185 Logical acknowledgement: (None)
	!	Logical negation	!(Conditional expression)	4	<input type="radio"/>	<input type="radio"/>	<input type="radio"/>	☞ Page 186 Logical negation: !
	*	Logical AND	(Conditional expression) * (conditional expression)	7	<input type="radio"/>	<input type="radio"/>	<input type="radio"/>	☞ Page 187 Logical AND: *
	+	Logical OR	(Conditional expression) + (conditional expression)	7	<input type="radio"/>	<input type="radio"/>	<input type="radio"/>	☞ Page 188 Logical OR: +
Comparison operation	==	Equal to	(Conditional expression) == (conditional expression)	7	<input type="radio"/>	<input type="radio"/>	<input type="radio"/>	☞ Page 189 Equal to: ==
	!=	Not equal to	(Conditional expression) != (conditional expression)	7	<input type="radio"/>	<input type="radio"/>	<input type="radio"/>	☞ Page 190 Not equal to: !=
	<	Less than	(Conditional expression) < (conditional expression)	7	<input type="radio"/>	<input type="radio"/>	<input type="radio"/>	☞ Page 191 Less than: <
	<=	Less than or equal to	(Conditional expression) <= (conditional expression)	7	<input type="radio"/>	<input type="radio"/>	<input type="radio"/>	☞ Page 192 Less than or equal to: <=
	>	More than	(Conditional expression) > (conditional expression)	7	<input type="radio"/>	<input type="radio"/>	<input type="radio"/>	☞ Page 193 More than: >
	>=	More than or equal to	(Conditional expression) >= (conditional expression)	7	<input type="radio"/>	<input type="radio"/>	<input type="radio"/>	☞ Page 194 More than or equal to: >=
Program control	IF - ELSE - IEND	Conditional branch control	IF(S) : ELSE : IEND	IF: 8 ELSE: 5 IEND: 1	<input type="radio"/>	<input type="radio"/>	—	☞ Page 195 Conditional branch control: IF - ELSE - IEND
	SELECT - CASE - SEND	Selective branch control	SELECT CASE(S1) : CEND CASE(Sn) : CEND CLELSE : CEND SEND	SELECT: 1 CASE: 8 CEND: 5 CLELSE: 1 SEND: 1	<input type="radio"/>	<input type="radio"/>	—	☞ Page 197 Selective branch control: SELECT - CASE - SEND
	FOR - NEXT	Repeat control with specified count	FOR(D)=(S1) TO (S2) STEP(S3) : NEXT	FOR: 18 NEXT: 15	<input type="radio"/>	<input type="radio"/>	—	☞ Page 199 Repeat control with specified count: FOR - NEXT
	BREAK	Force termination of repeat control	BREAK	5	<input type="radio"/>	<input type="radio"/>	—	☞ Page 201 Forced termination of repeat control: BREAK

Classification	Symbol	Function	Format	Basic steps	Usable step		Y/N transition's conditional expression	Section of reference
					F/FS	G		
Motion dedicated function	CHGV	Speed change request	CHGV((S1),(S2))	7	○	○	—	☞ Page 202 Speed change request: CHGV
	CHGVS	Command generation axis speed change request	CHGVS((S1),(S2))	7	○	○	—	☞ Page 206 Command generation axis speed change request: CHGVS
	CHGT	Torque limit value change request	CHGT((S1),(S2),(S3))	10	○	○	—	☞ Page 210 Torque limit value change request: CHGT
	CHGP	Target position change request	CHGP((S1),(S2),(S3))	11	○	○	—	☞ Page 212 Target position change request: CHGP
	MCNST	Machine program operation start request	MCNST((S1),(S2))	7	○	○	—	☞ Page 220 Machine program operation start request: MCNST
Advanced synchronous control dedicated function	CAMRD	Cam data read	CAMRD(S1),(S2),(n),(D),(S3)	16	○	○	—	☞ Page 222 Cam data read: CAMRD
	CAMWR	Cam data write	CAMWR(S1),(S2),(n),(S3),(D)	16	○	○	—	☞ Page 227 Cam data write: CAMWR
	CAMMK	Cam auto-generation	CAMMK(S1),(S2),(S3),(D)	13	○	○	—	☞ Page 231 Cam auto-generation: CAMMK
	CAMPSCCL	Cam position calculation	CAMPSCCL(S1),(S2),(D)	12	○	○	—	☞ Page 243 Cam position calculation: CAMPSCCL
Vision system dedicated function	MVOPEN	Open line	MVOPEN(S1),(S2)	8	○	○	—	☞ Page 246 Open line: MVOPEN
	MVLOAD	Load a program	MVLOAD(S1),(S2)	8	○	○	—	☞ Page 247 Load a program: MVLOAD
	MVTRG	Send an image acquisition trigger	MVTRG(S1),(S2)	8	○	○	—	☞ Page 248 Send an image acquisition trigger: MVTRG
	MVPST	Start a program	MVPST(S1),(S2)	8	○	○	—	☞ Page 249 Start a program: MVPST
	MVIN	Input data	MVIN(S1),(S2),(D),(S3)	15 or more	○	○	—	☞ Page 251 Input data: MVIN
	MVOUT	Output data	MVOUT(S1),(S2),(S3),(S4)	15 or more	○	○	—	☞ Page 253 Output data: MVOUT
	MVFIN	Reset a status storage device	MVFIN(S)	6	○	○	—	☞ Page 255 Reset a status storage device: MVFIN
	MVCLOSE	Close line	MVCLOSE(S)	6	○	○	—	☞ Page 256 Close line: MVCLOSE
	MVCOM	Send a command for native mode	MVCOM(S1),(S2),(D),(S3),(S4)	19 or more	○	○	—	☞ Page 257 Send a command for native mode: MVCOM
Add-on dedicated function	MCFUN	Call add-on module	MCFUN(S1),(S2),(D1),(D2)	11 or more	○	○	—	☞ Page 260 Call add-on module: MCFUN

Classification	Symbol	Function	Format	Basic steps	Usable step		Y/N transition's conditional expression	Section of reference
					F/FS	G		
Others	EI	Event task enable	EI	1	○	○	—	☞ Page 262 Event task enable: EI
	DI	Event task disable	DI	1	○	○	—	☞ Page 263 Event task disable: DI
	NOP	No operation	NOP	1	○	○	—	☞ Page 264 No operation: NOP
	BMOV	Block transfer	BMOV(D),(S),(n)	12	○	○	—	☞ Page 265 Block transfer: BMOV
	FMOV	Same data block transfer	FMOV(D),(S),(n)	12	○	○	—	☞ Page 267 Same data block transfer: FMOV
	TO	Write device data to buffer memory	TO(D1),(D2),(S),(n)	14	○	○	—	☞ Page 269 Write device data to buffer memory: TO
	FROM	Read device data from buffer memory	FROM(D),(S1),(S2),(n)	14	○	○	—	☞ Page 271 Read device data from buffer memory: FROM
	RTO	Write buffer memory data to head module	RTO(D1),(D2),(D3),(S),(n), (D4)	21	○	○	—	☞ Page 274 Write buffer memory data to head module: RTO
	RFROM	Read buffer memory data from head module	RFROM(D),(S1),(S2),(S3), (n), (D1)	21	○	○	—	☞ Page 277 Read buffer memory data from head module: RFROM
	TIME	Time to wait	TIME(S)	8	—	○	—	☞ Page 280 Time to wait: TIME

Rough calculation of single program for operation control/transition program

$2 + (2 + \text{Total number of basic steps in 1 block} + \text{Number of 32-bit constants}/1 \text{ block} \times 1 + \text{Number of 64-bit constants}/1 \text{ block} \times 3) \times \text{Number of blocks (steps)}$
 (1 step = 2 bytes)

1.2 Structure of the Motion CPU Program

- By using the sequence program in the PLC CPU, Motion dedicated PLC instructions in the Motion CPU perform the following controls.
 - Start of Motion SFC program
 - Start of servo program
 - Direct positioning (perform positioning control by sequence program)
 - Change of current value/speed/torque limit value
 - Start of machine program operation
 - Start of event task
- Motion CPU programs are created in the Motion SFC flowchart format. In positioning control, the motion control of servomotors is performed using the servo programs specified by motion-control steps in a Motion SFC program.
- By setting the synchronous control parameter and starting the synchronous control for each output axis, the advanced synchronous control is performed in synchronization with the input axis (servo input axis, command generation axis, synchronous encoder axis).
- In machine control, the machine is controlled by using machine positioning data set in the devices, and the settings in the machine control parameters for the machine type being used.
- Refer to the following for the details of Motion dedicated PLC instructions in the PLC CPU, Motion SFC programs, motion control in positioning control, motion control in advanced synchronous control, and motion control in machine control.

Item	Reference
Motion dedicated PLC instructions in the PLC CPU	☞ Page 30 MOTION DEDICATED PLC INSTRUCTION
Motion SFC program	☞ Page 93 MOTION SFC PROGRAMS
Motion control in positioning control (Servo program)	📖 MELSEC iQ-R Motion controller Programming Manual (Positioning Control)
Motion control in advanced synchronous control (Synchronous control parameter)	📖 MELSEC iQ-R Motion controller Programming Manual (Advanced Synchronous Control)
Motion control in machine control (Machine control parameter)	📖 MELSEC iQ-R Motion controller Programming Manual (Machine Control)

2 MOTION DEDICATED PLC INSTRUCTION

2.1 Outline of Motion Dedicated PLC Instruction

Motion dedicated PLC instruction is used to access the device data and start-up program of Motion CPU from PLC CPU and other CPU. Motion dedicated PLC instruction is transmitted through the CPU dedicated instruction transmission area set up in system area on the CPU buffer memory or the CPU buffer memory (fixed scan communication area). Outline operation for Motion dedicated PLC instruction is shown below.

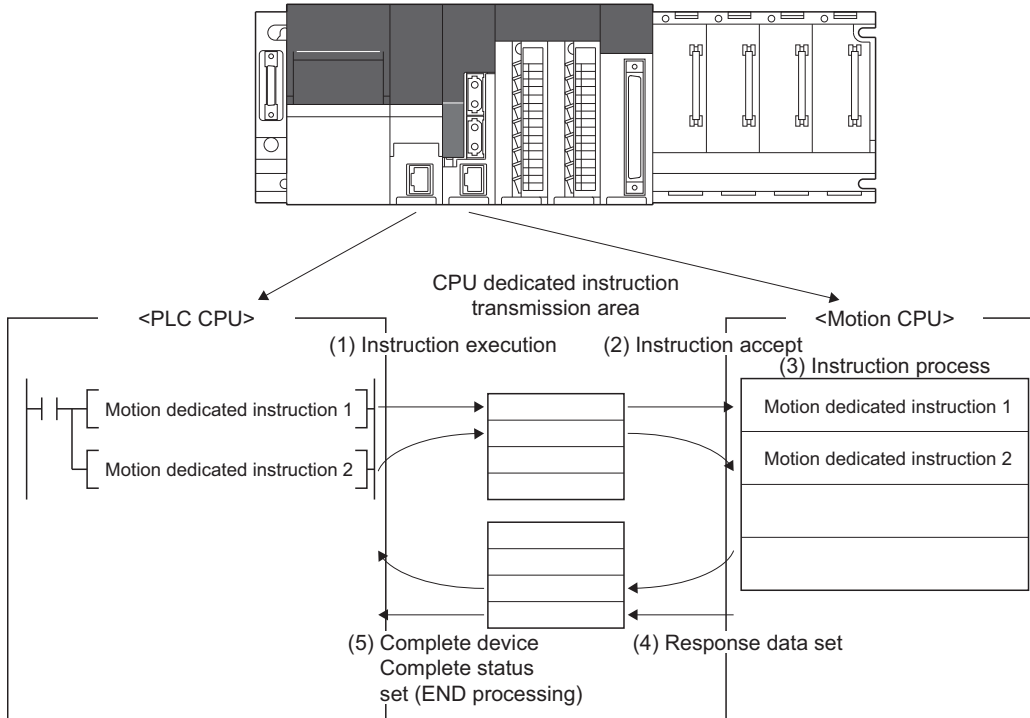

The memory area used and the accepting cycle on the Motion CPU side according to the instruction are shown below.





Instruction	Memory used	Accepting cycle on Motion CPU side
M(P).□ instructions	CPU buffer memory	Non-fixed cycle (immediate)
D(P).□ instructions	CPU buffer memory (fixed scan communication area)	Fixed cycle (CPU communication cycle)

2.2 Motion Dedicated PLC Instruction

The Motion dedicated PLC instruction that can be executed toward the Motion CPU is shown below.

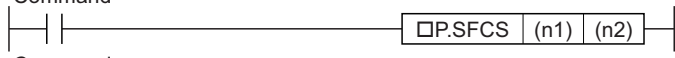
Instruction		Description	Reference
M(P).□	D(P).□		
M(P).SFCS	D(P).SFCS	Start request of the specified Motion SFC program	☞ Page 32 Motion SFC start request from the PLC CPU to the Motion CPU: M(P).SFCS/D(P).SFCS
M(P).SVST	D(P).SVST	Start request of the specified servo program	☞ Page 35 Servo program start request from the PLC CPU to the Motion CPU: M(P).SVST/D(P).SVST
M(P).SVSTD	D(P).SVSTD	Direct positioning start request	☞ Page 40 Direct positioning start instruction from the PLC CPU to the Motion CPU: M(P).SVSTD/D(P).SVSTD
M(P).CHGA	D(P).CHGA	Current value change request of the specified axis	☞ Page 52 Current value change instruction from the PLC CPU to the Motion CPU: M(P).CHGA/D(P).CHGA
M(P).CHGAS	D(P).CHGAS	Current value change request of the specified command generation axis	☞ Page 56 Current value change instruction of command generation axis from the PLC CPU to the Motion CPU: M(P).CHGAS/D(P).CHGAS
M(P).CHGV	D(P).CHGV	Speed change request of the specified axis	☞ Page 60 Speed change instruction from the PLC CPU to the Motion CPU: M(P).CHGV/D(P).CHGV
M(P).CHGVS	D(P).CHGVS	Speed change request of the specified command generation axis	☞ Page 65 Speed change instruction of command generation axis from the PLC CPU to the Motion CPU: M(P).CHGVS/D(P).CHGVS
M(P).CHGT	D(P).CHGT	Torque control value change request of the specified axis	☞ Page 70 Torque limit value change request instruction from the PLC CPU to the Motion CPU: M(P).CHGT/D(P).CHGT
M(P).MCNST	D(P).MCNST	Start request of machine program operation	☞ Page 73 Machine program operation start request from the PLC CPU to the Motion CPU: M(P).MCNST/D(P).MCNST
M(P).DDWR	D(P).DDWR	Write device data of the self CPU to the device of another Motion CPU	☞ MELSEC iQ-R Programming Manual (Instructions, Standard Functions/Function Blocks)
M(P).DDRDR	D(P).DDRDR	Read device data of another Motion CPU to the device of self CPU	
M(P).BITWR	D(P).BITWR	Write bit operation to the bit device of another Motion CPU	☞ Page 77 Write bit device to the Motion CPU: M(P).BITWR/D(P).BITWR
M(P).GINT	D(P).GINT	Execute request of an event task of Motion SFC program	☞ Page 80 Interrupt instruction to the other CPU: M(P).GINT/D(P).GINT

Motion SFC start request from the PLC CPU to the Motion CPU: M(P).SFCS/D(P).SFCS

Instruction	Condition	Sequence program*1
MP.SFCS DP.SFCS		Command  Command 
M.SFCS D.SFCS		Command  Command 

*1 □: Instruction (M(P).SFCS: M, D(P).SFCS: D)

Setting data

Usable devices

○: Usable, △: Usable partly

Setting data*3	Usable devices											
	Internal devices (System, User)		File register		Link direct device J□\□		Module access device U□\G□		Index register Z□	Constant		Others
	Bit	Word	Bit	Word	Bit	Word	Bit	Word		Decimal K, Hexadecimal H	Real character string	
(n1)		○		○						○		
(n2)		○		○						○		
(D1)*1	△*2		△*2									
(D2)*1		△*2		△*2								

*1 Omission possible with both of (D1) and (D2) omission.

*2 Local devices cannot be used.

*3 Setting data (n1) to (D2): Index qualification possible (except constant)

Description, range, setting side, data type

Setting data	Description	Setting range	Set by	Data type
(n1)	(First I/O No. of the target CPU)/16 Value to specify actually is the following.*2 CPU No.2: 3E1H, CPU No.3: 3E2H, CPU No.4: 3E3H	3E1H to 3E3H	User	16-bit binary
(n2)	Motion SFC program No. to start.	0 to 511*3	User	16-bit binary
(D1)*1	Complete devices • (D1+0): Device which make turn on for one scan at accept completion of instruction. • (D1+1): Device which make turn on for one scan at accept abnormal completion of instruction. ("D1+0" also turns on at the abnormal completion.)	—	System	Bit
(D2)*1	Complete status storage device	—	System	Word

*1 Omission possible with both of (D1) and (D2) omission.

*2 Motion CPU cannot be set as CPU No.1 in the Multiple CPU configuration.

*3 For operating system software version "09" or earlier, 0 to 255.

Processing details

Controls

Request to start the Motion SFC program of program No. specified with (n2). The Motion SFC program can start any task setting of the normal task, event task and NMI task.

■ Operation

Outline operation between CPUs at the MP.SFCS and DP.SFCS instruction execution is shown below.

• MP.SFCS instruction

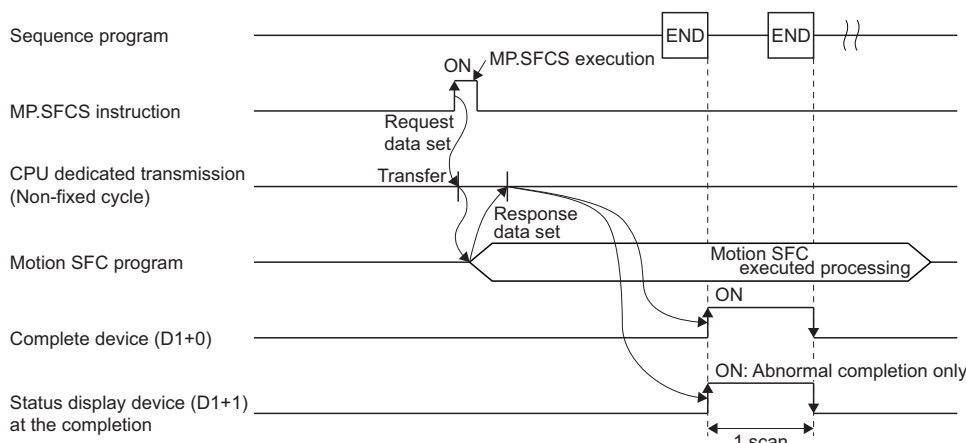

• DP.SFCS instruction

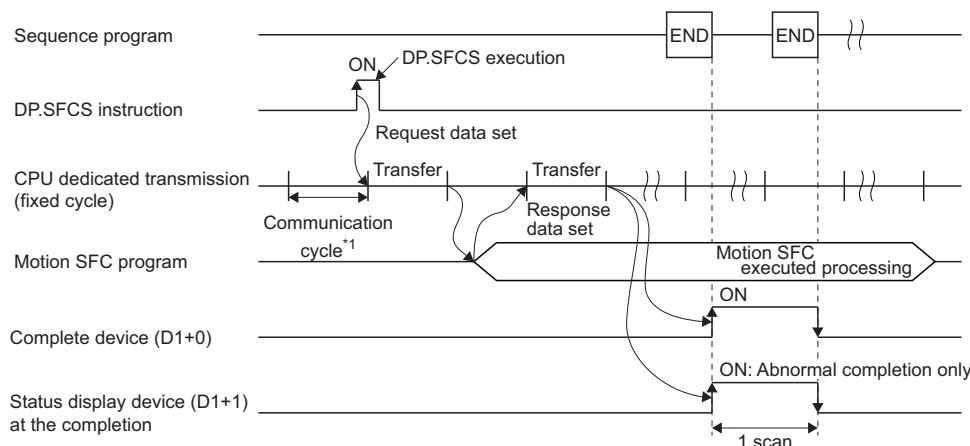

*1 Set in [System Parameter] ⇒ [Multiple CPU settings] in GX Works3

Operation error

- The abnormal completion in the case shown below, and the error code is stored in the device specified with the complete status storage device (D2). If the complete status storage device (D2) is omitted, an error is not detected and operation becomes "No operation".

Complete status*1 (Error code) (H)	Error factor	Corrective action
0010	Instruction request to Motion CPU from PLC CPU exceeds the permissible value.	Check the sequence program, and correct it.
2100	There are 65 or more simultaneous M(P).SFCS/D(P).SFCS instruction requests to the Motion CPU from the PLC CPU, therefore the Motion CPU cannot process them.	
2200	The Motion SFC program No. to start is outside the range of 0 to 511 (for operating system software version "09" or earlier, 0 to 255).	

*1 0000H (Normal)

- An operation error occurs, "Latest self-diagnosis error detection (SM0)" is turned on, and an error code is stored in "Latest self-diagnosis error (SD0)" in the cases shown below.

Error code (H)*1	Error factor	Corrective action
2800	The start I/O number (the first 3 digits when expressed in 4-digit hexadecimal) of the specified other CPU module is outside the range of 3E0H to 3E3H.	Check the sequence program, and correct it.
2801	The specified other CPU module is wrong. <ul style="list-style-type: none"> The reserved CPU is specified. The uninstalled CPU is specified. 	

*1 0000H (Normal)

Program example

■ Program which starts the Motion SFC program No.10 of the Motion CPU (CPU No.2), when M0 turned ON.

- (Example 1) Program which omits the complete device and complete status.

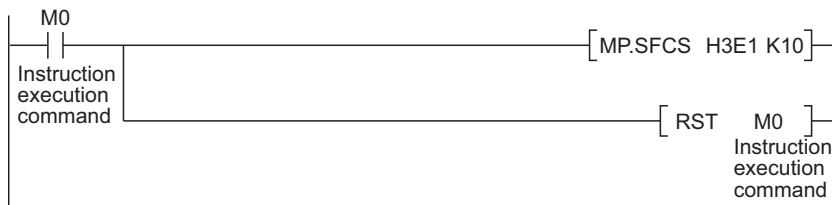

- (Example 2) Program which uses the complete device and complete status.

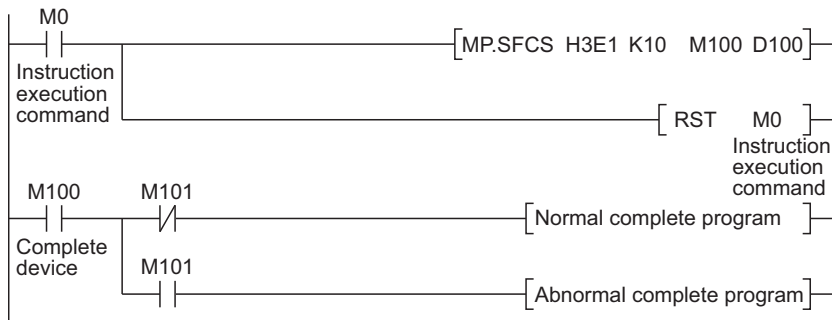

Servo program start request from the PLC CPU to the Motion CPU: M(P).SVST/D(P).SVST

Instruction	Condition	Sequence program*1
MP.SVST DP.SVST		Command Command
M.SVST D.SVST		Command Command

*1 □: Instruction (M(P).SVST: M, D(P).SVST: D)

Setting data

Usable devices

○: Usable, △: Usable partly

Setting data*3	Usable devices											
	Internal devices (System, User)		File register		Link direct device J□\□		Module access device U□\G□		Index register Z□	Constant		Others
	Bit	Word	Bit	Word	Bit	Word	Bit	Word		Decimal K, Hexadecimal H	Real character string	
(n1)		○		○						○		
(S1)		○		○							○	
(n2)		○		○						○		
(D1)*1	△*2		△*2									
(D2)*1		△*2		△*2								

*1 Omission possible with both of (D1) and (D2) omission.

*2 Local devices cannot be used.

*3 Setting data (n1) to (D2): Index qualification possible (except constant)

Description, range, setting side, data type

Setting data	Description	Setting range	Set by	Data type
(n1)	(First I/O No. of the target CPU)/16 Value to specify actually is the following.*2 CPU No.2: 3E1H, CPU No.3: 3E2H, CPU No.4: 3E3H	3E1H to 3E3H	User	16-bit binary
(S1)	Axis No.("Jn")*3 to start. R64MTCPU: J1 to J64 R32MTCPU: J1 to J32 R16MTCPU: J1 to J16	1 to 64	User	Character string
(n2)	Servo program No. to execute	0 to 8191*4	User	16-bit binary
(D1)*1	Complete devices • (D1+0): Device which make turn on for one scan at accept completion of instruction. • (D1+1): Device which make turn on for one scan at accept abnormal completion of instruction. ("D1+0" also turns on at the abnormal completion.)	—	System	Bit
(D2)*1	Complete status storage device	—	System	Word

*1 Omission possible with both of (D1) and (D2) omission.

*2 Motion CPU cannot be set as CPU No.1 in the Multiple CPU configuration.

*3 "n" shows the numerical value correspond to axis No. (n=1 to 64)

*4 For operating system software version "09" or earlier, 0 to 4095.

Processing details

■ Controls

- Request to start the servo program specified with (n2) program No.
- It is necessary to take an inter-lock by the start accept flag of CPU buffer memory and user device so that multiple instructions may not be executed toward the same axis of the same Motion CPU No.



Refer to the start accept flag (system area) for details of the start accept flag. (Page 83 Start accept flag (System area))

■ Operation

Outline operation between CPUs at the MP.SVST and DP.SVST instruction execution is shown below.

• MP.SVST instruction

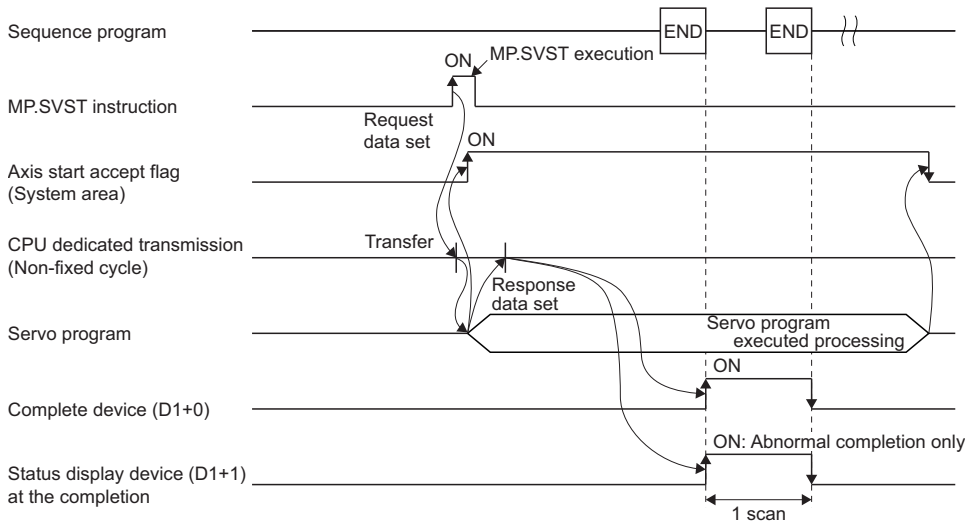

• DP.SVST instruction

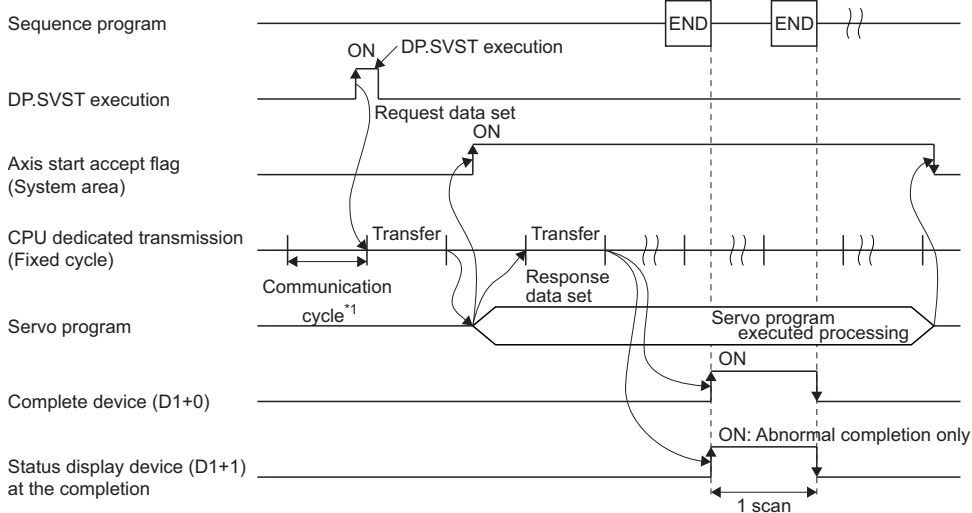

*1 Set in [System Parameter] ⇒ [Multiple CPU settings] in GX Works3

■ Setting of the starting axis

The starting axis set as (S1) is set J + Axis No. in a character string " ".

Motion CPU	(S1) usable range
R64MTCPU	1 to 64
R32MTCPU	1 to 32
R16MTCPU	1 to 16

Up to 12 axes can be set. Set them as shown below. Set "J" in a capital letter or small letter and use the axis No. set in the servo network setting as the axis No. to start. Refer to the following for servo network settings.

📖 MELSEC iQ-R Motion controller Programming Manual (Common)

Also, the axis No. to start does not need to be in order.

Ex.

When multiple axes (Axis1, Axis2, Axis10, Axis11) are set.

- "J1J2J10J11"
- "j1j2j10j11"
- "J1 J2 J10 J11"

If the start axis specified by (S1), and the axis No. specified in the servo program to be started are verified and match, the servo program starts. If the specified axes do not match, a minor error (error code: 19FBH) occurs, and the servo program does not start.

When an empty character string " " is specified to (S1), the axis specified in the servo program starts without verifying axis No.

When indirectly specifying an axis No. in the servo program, specify " " to (S1).

Point

[When " " is specified to (S1)]

When omitting the axis No., the timing of the start accept flag and start accept flag for the command generation axis turning ON is slower than when the axis No. is set. (📖 Page 83 Start accept flag (System area))

- When axis No. is set: When instruction is received
- When axis No. is omitted: When instruction is analysed

[When an axis No. is specified to (S1)]

When starting the START instruction with M(P).SVST/D(P).SVST, regardless of whether all start axes are set, if one or more axis No. of the start axes is specified in each servo program instruction in the START instruction, the servo program starts without error.

■ Start accept flag (System area)

The complete status of start accept flag is stored in the address of start accept flag in the CPU buffer memory for target CPU.

CPU buffer memory address () is decimal address	Description																									
204H(516) 205H(517) 206H(518) 207H(519)	<p>The start accept flag for 64 axes are stored corresponding to each bit. Bits are actually set as the following:</p> <ul style="list-style-type: none"> • R64MTCPU: J1 to J64 • R32MTCPU: J1 to J32 • R16MTCPU: J1 to J16 <p>OFF: Start accept enable ON: Start accept disable</p> <table border="1"> <thead> <tr> <th></th> <th>b15</th> <th>b2</th> <th>b1</th> <th>b0</th> </tr> </thead> <tbody> <tr> <td>204H(516) address</td> <td>J16</td> <td>••••••••</td> <td>J2</td> <td>J1</td> </tr> <tr> <td>205H(517) address</td> <td>J32</td> <td>••••••••</td> <td>J18</td> <td>J17</td> </tr> <tr> <td>206H(518) address</td> <td>J48</td> <td>••••••••</td> <td>J34</td> <td>J33</td> </tr> <tr> <td>207H(519) address</td> <td>J64</td> <td>••••••••</td> <td>J50</td> <td>J49</td> </tr> </tbody> </table>		b15	b2	b1	b0	204H(516) address	J16	••••••••	J2	J1	205H(517) address	J32	••••••••	J18	J17	206H(518) address	J48	••••••••	J34	J33	207H(519) address	J64	••••••••	J50	J49
	b15	b2	b1	b0																						
204H(516) address	J16	••••••••	J2	J1																						
205H(517) address	J32	••••••••	J18	J17																						
206H(518) address	J48	••••••••	J34	J33																						
207H(519) address	J64	••••••••	J50	J49																						
20EH(526) 20FH(527) 210H(528) 211H(529)	<p>The command generation axis start accept flag for 64 axes are stored corresponding to each bit. Bits are actually set as the following:</p> <ul style="list-style-type: none"> • R64MTCPU: J1 to J64 • R32MTCPU: J1 to J32 • R16MTCPU: J1 to J16 <p>OFF: Start accept enable ON: Start accept disable</p> <table border="1"> <thead> <tr> <th></th> <th>b15</th> <th>b2</th> <th>b1</th> <th>b0</th> </tr> </thead> <tbody> <tr> <td>20EH(526) address</td> <td>J16</td> <td>••••••••</td> <td>J2</td> <td>J1</td> </tr> <tr> <td>20FH(527) address</td> <td>J32</td> <td>••~••••••</td> <td>J18</td> <td>J17</td> </tr> <tr> <td>210H(528) address</td> <td>J48</td> <td>••••••~••</td> <td>J34</td> <td>J33</td> </tr> <tr> <td>211H(529) address</td> <td>J64</td> <td>••••••~••</td> <td>J50</td> <td>J49</td> </tr> </tbody> </table>		b15	b2	b1	b0	20EH(526) address	J16	••••••••	J2	J1	20FH(527) address	J32	••~••••••	J18	J17	210H(528) address	J48	••••••~••	J34	J33	211H(529) address	J64	••••••~••	J50	J49
	b15	b2	b1	b0																						
20EH(526) address	J16	••••••••	J2	J1																						
20FH(527) address	J32	••~••••••	J18	J17																						
210H(528) address	J48	••••••~••	J34	J33																						
211H(529) address	J64	••••••~••	J50	J49																						

Operation error

- The abnormal completion in the case shown below, and the error code is stored in the device specified with the complete status storage device (D2). If the complete status storage device (D2) is omitted, an error is not detected and operation becomes "No operation".

Complete status*1 (Error code) (H)	Error factor	Corrective action
0010	Instruction request to Motion CPU from PLC CPU exceeds the permissible value.	Check the sequence program, and correct it.
2100	There are 257 or more simultaneous M(P).SVST/D(P).SVST/M(P).SVSTD/D(P).SVSTD/M(P).CHGA/D(P).CHGA/M(P).CHGAS/D(P).CHGAS/M(P).MCNST/D(P).MCNST instruction requests to the Motion CPU from the PLC CPU, therefore the Motion CPU cannot process them.	
2201	The servo program No. to execute is outside the range of 0 to 8191 (for operating system software version "09" or earlier, 0 to 4095).	
2202	Axis No. set by M(P).SVST/D(P).SVST instruction is wrong.	

*1 0000H (Normal)

- An operation error occurs, "Latest self-diagnosis error detection (SM0)" is turned on, and an error code is stored in "Latest self-diagnosis error (SD0)" in the cases shown below.

Error code (H)*1	Error factor	Corrective action
2800	The start I/O number (the first 3 digits when expressed in 4-digit hexadecimal) of the specified other CPU module is outside the range of 3E0H to 3E3H.	Check the sequence program, and correct it.
2801	<p>The specified other CPU module is wrong.</p> <ul style="list-style-type: none"> • The reserved CPU is specified. • The uninstalled CPU is specified. 	

*1 0000H (Normal)

Program example

■ Program which requests to start of the servo program No.10 toward Axis 1, Axis 2 of the Motion CPU (CPU No.2), when M0 turned ON

- (Example 1) Program which omits the complete device and complete status.

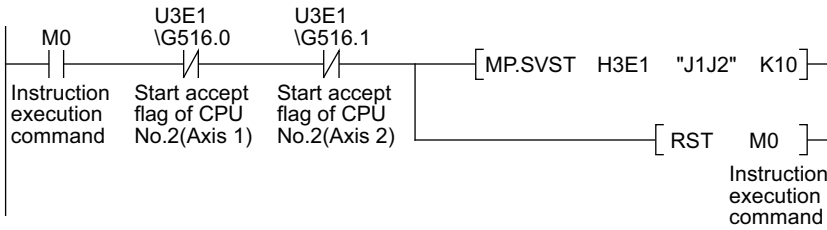

- (Example 2) Program which uses the complete device and complete status.

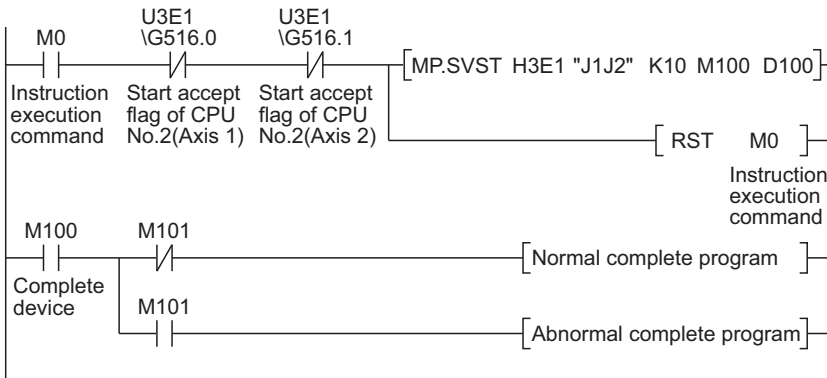

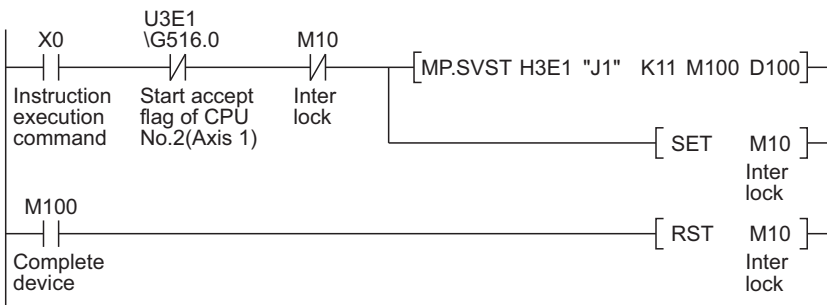

■ Program which executes continuous start of the servo program No.11 toward Axis 1 of the Motion CPU (CPU No.2), while X0 is ON

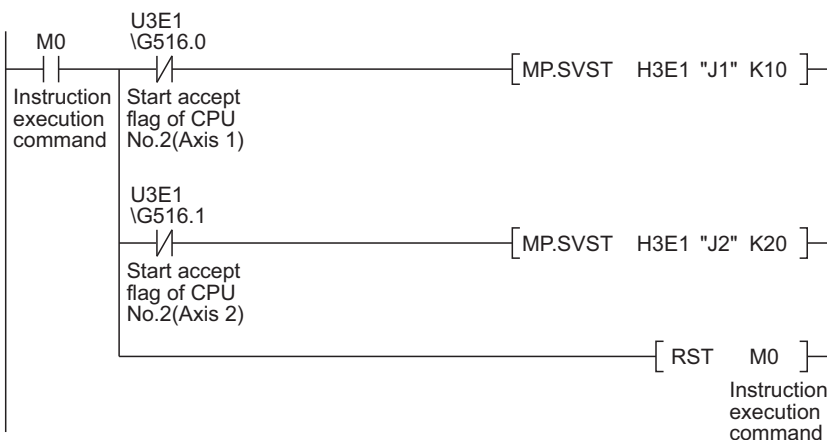

■ Program which continuously executes the servo program No.10 toward Axis 1 of the Motion CPU (CPU No.2) and the servo program No.20 toward Axis 2, when M0 turned ON

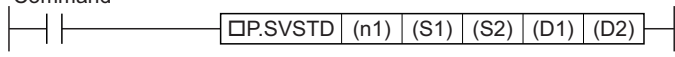

Direct positioning start instruction from the PLC CPU to the Motion CPU: M(P).SVSTD/D(P).SVSTD

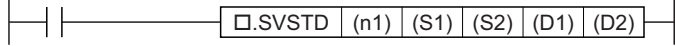
Instruction	Condition	Sequence program*1
MP.SVSTD		Command 
DP.SVSTD		
M.SVSTD		Command 
D.SVSTD		

*1 □: Instruction (M(P).SVSTD: M, D(P).SVSTD: D)

Setting data

Usable devices



○: Usable, △: Usable partly

Setting data*2	Usable devices											
	Internal devices (System, User)		File register		Link direct device J□□		Module access device U□\G□		Index register Z□	Constant		Others
	Bit	Word	Bit	Word	Bit	Word	Bit	Word		Decimal K, Hexadecimal H	Real character string	
(n1)		○		○						○		
(S1)		△*1		△*1								
(S2)		○		○								
(D1)												△
(D2)	△*1		△*1									

*1 Local devices cannot be used.

*2 Except for setting data (D1), index qualification possible (except constant)

Description, range, setting side, data type



Setting data	Description	Setting range	Set by	Data type
(n1)	(First I/O No. of the target CPU)/16 Value to specify actually is the following.*1 CPU No.2: 3E1H, CPU No.3: 3E2H, CPU No.4: 3E3H	3E1H to 3E3H	User	16-bit binary
(S1)	First device of the self CPU where the control data is stored.	 Page 40 Control data	User	Word
(S2)	First device of the self CPU where the positioning data area is stored.	 Page 41 Positioning data area	User	Word
(D1)	Device of the following target Motion CPU • Bit device of the target Motion CPU used for fixed position stop command • Word device of the target Motion CPU that stores the position follow-up address Enclose the character string with double quotations. When not using for the above devices, enclose a blank space with double quotations (" ").	—	User	Character string
(D2)	Complete devices • (D2+0): Device which make turn on for one scan at completion of instruction. • (D2+1): Device which make turn on for one scan at abnormal completion of instruction. ("D2+0" also turns on at the abnormal completion.)	—	System	Bit



*1 Motion CPU cannot be set as CPU No.1 in the Multiple CPU configuration.

Control data

Device (S1)	Item	Setting data	Setting range	Set by
+0	Complete status	The status at the instruction completion is stored. 0: No error (Normal completion) Except 0: Error code	—	System
+1	Number of positioning data points	Set the size of the positioning data area in units of words.	14 to 2044	User

■ Positioning data area

Device (S2)*1	Name	Description	Setting range	
+0	Positioning type/Number of points(R)	Set the number of points for positioning points when starting continuous trajectory control (CPSTART). Set "0" for a control other than continuous trajectory control (CPSTART).	0: Start a control other than continuous trajectory control (CPSTART). 1 to 128: Start continuous trajectory control (CPSTART).	
+1	Positioning data items setting	Set the positioning data used to start positioning. Valid/Invalid is set in units of bits.	0: Invalid 1: Valid ( Page 45 Setting of positioning data items)	
+2	Positioning data item No.1	Set the value of positioning data in units of two words	Range of the data item set to "1: Valid" in setting of positioning data items ( Page 45 Setting of positioning data items)	
+3				
⋮	⋮			
+(2V)	Positioning data item No.(V)			
+(2V+1)				
+(2V+2)	Axis 1 data	Axis No..	Set the axis No. R64MTCPU: 1 to 64, 1001 to 1064 ^{*2} R32MTCPU: 1 to 32, 1001 to 1032 ^{*2} R16MTCPU: 1 to 16, 1001 to 1016 ^{*2}	
+(2V+3)		Unusable	Set to "0" 0	
+(2V+4)	Positioning point No.1	[Da.2] Control mode/ [Da.29] Interpolation axis speed designation	Set the control mode and interpolation axis speed designation method.  Page 46 Positioning point data	
+(2V+5)		[Da.10] M-code	Set M-code. Set the number of pitches against the linear axis during helical interpolation. M-code: 0 to 32767 Number of pitches: 0 to 999	
+(2V+6)		[Da.11] Dwell time	Set the dwell time 0 to 5000 [ms]	
+(2V+7)		Torque limit value during operation ^{*3}	Set the torque limit value for every point 1 to 10000 [×0.1%]	
+(2V+8)		[Da.8] Command speed	Set the positioning speed	mm: 1 to 600000000×10 ⁻² [mm/min] inch: 1 to 600000000×10 ⁻³ [inch/min] degree: 1 to 2147483647×10 ⁻³ [degree/min] ^{*4} pulse: 1 to 2147483647[pulse/s]
+(2V+9)				
+(2V+10)		[Da.6] Positioning address/Travel value	Set the positioning address/travel value -2147483648 to 2147483647 [Optional units]	
+(2V+11)				
+(2V+12)		[Da. 7] Arc address	Set auxiliary point/central point address/radius during circular interpolation -2147483648 to 2147483647 [Optional units]	
+(2V+13)				
⋮		⋮	⋮	⋮
+(2V+10R-6)		Positioning point No.(R)	[Da.2] Control mode/ [Da.29] Interpolation axis speed designation	The number of positioning points set in "Positioning type/Number of points" is valid.  Page 46 Positioning point data
+(2V+10R-5)			[Da.10] M-code	When "0" is set, only "positioning point No. 1" is valid. M-code: 0 to 32767 Number of pitches: 0 to 999
+(2V+10R-4)	[Da.11] Dwell time		0 to 5000 [ms]	
+(2V+10R-3)	Torque limit value during operation ^{*3}		1 to 10000 [×0.1%]	
+(2V+10R-2)	[Da.8] Command speed		mm: 1 to 600000000×10 ⁻² [mm/min] inch: 1 to 600000000×10 ⁻³ [inch/min] degree: 1 to 2147483647×10 ⁻³ [degree/min] ^{*4} pulse: 1 to 2147483647[pulse/s]	
+(2V+10R-1)				
+(2V+10R)	[Da.6] Positioning address/Travel value		-2147483648 to 2147483647 [Optional units]	
+(2V+10R+1)				
+(2V+10R+2)	[Da. 7] Arc address		-2147483648 to 2147483647 [Optional units]	
+(2V+10R+3)				

Device (S2)*1	Name		Description	Setting range	
+ (2V+10R+4)	Axis 2 data	Axis No.	The number of positioning points set in "Positioning type/Number of points" is valid.	R64MTCPU: 1 to 64, 1001 to 1064 ^{*2} R32MTCPU: 1 to 32, 1001 to 1032 ^{*2} R16MTCPU: 1 to 16, 1001 to 1016 ^{*2}	
+ (2V+10R+5)		Unusable	When "0" is set, only "positioning point No. 1" is valid.	0	
+ (2V+10R+6)		Positioning point No.1	[Da.2] Control mode/ [Da.29] Interpolation axis speed designation		 Page 46 Positioning point data
+ (2V+10R+7)			[Da.10] M-code		M-code: 0 to 32767 Number of pitches: 0 to 999
+ (2V+10R+8)			[Da.11] Dwell time		0 to 5000 [ms]
+ (2V+10R+9)			Torque limit value during operation ^{*3}		1 to 10000 [$\times 0.1\%$]
+ (2V+10R+10)			[Da.8] Command speed		mm: 1 to 600000000 $\times 10^{-2}$ [mm/min] inch: 1 to 600000000 $\times 10^{-3}$ [inch/min] degree: 1 to 2147483647 $\times 10^{-3}$ [degree/min] ^{*4} pulse: 1 to 2147483647[pulse/s]
+ (2V+10R+12)			[Da.6] Positioning address/Travel value		-2147483648 to 2147483647 [Optional units]
+ (2V+10R+13)			[Da. 7] Arc address		-2147483648 to 2147483647 [Optional units]
+ (2V+10R+14)					
+ (2V+10R+15)					
⋮			⋮		⋮
+ (2V+20R-4)		Axis 3 data	Positioning point No.(R)	[Da.2] Control mode/ [Da.29] Interpolation axis speed designation	 Page 46 Positioning point data
+ (2V+20R-3)			[Da.10] M-code		M-code: 0 to 32767 Number of pitches: 0 to 999
+ (2V+20R-2)	[Da.11] Dwell time			0 to 5000 [ms]	
+ (2V+20R-1)	Torque limit value during operation ^{*3}			1 to 10000 [$\times 0.1\%$]	
+ (2V+20R)	[Da.8] Command speed			mm: 1 to 600000000 $\times 10^{-2}$ [mm/min] inch: 1 to 600000000 $\times 10^{-3}$ [inch/min] degree: 1 to 2147483647 $\times 10^{-3}$ [degree/min] ^{*4} pulse: 1 to 2147483647[pulse/s]	
+ (2V+20R+1)	[Da.6] Positioning address/Travel value			-2147483648 to 2147483647 [Optional units]	
+ (2V+20R+2)	[Da. 7] Arc address			-2147483648 to 2147483647 [Optional units]	
+ (2V+20R+3)					
+ (2V+20R+4)					
+ (2V+20R+5)					
+ (2V+20R+6)	Axis No.			R64MTCPU: 1 to 64, 1001 to 1064 ^{*2} R32MTCPU: 1 to 32, 1001 to 1032 ^{*2} R16MTCPU: 1 to 16, 1001 to 1016 ^{*2}	
+ (2V+20R+7)	Unusable			0	
+ (2V+20R+8)	Positioning point No.1		[Da.2] Control mode/ [Da.29] Interpolation axis speed designation		 Page 46 Positioning point data
+ (2V+20R+9)			[Da.10] M-code		M-code: 0 to 32767 Number of pitches: 0 to 999
+ (2V+20R+10)		[Da.11] Dwell time		0 to 5000 [ms]	
+ (2V+20R+11)		Torque limit value during operation ^{*3}		1 to 10000 [$\times 0.1\%$]	
+ (2V+20R+12)		[Da.8] Command speed		mm: 1 to 600000000 $\times 10^{-2}$ [mm/min] inch: 1 to 600000000 $\times 10^{-3}$ [inch/min] degree: 1 to 2147483647 $\times 10^{-3}$ [degree/min] ^{*4} pulse: 1 to 2147483647[pulse/s]	
+ (2V+20R+13)		[Da.6] Positioning address/Travel value		-2147483648 to 2147483647 [Optional units]	
+ (2V+20R+14)		[Da. 7] Arc address		-2147483648 to 2147483647 [Optional units]	
+ (2V+20R+15)					
+ (2V+20R+16)					
+ (2V+20R+17)					
⋮	⋮		⋮		

Device (S2)*1	Name		Description	Setting range		
+ (2V+30R-2)	Axis 3 data	Positioning point No.(R)	[Da.2] Control mode/ [Da.29] Interpolation axis speed designation	The number of positioning points set in "Positioning type/Number of points" is valid.	☞ Page 46 Positioning point data	
+ (2V+30R-1)			[Da.10] M-code	When "0" is set, only "positioning point No. 1" is valid.	M-code: 0 to 32767 Number of pitches: 0 to 999	
+ (2V+30R)			[Da.11] Dwell time		0 to 5000 [ms]	
+ (2V+30R+1)			Torque limit value during operation*3		1 to 10000 [×0.1%]	
+ (2V+30R+2)			[Da.8] Command speed		mm: 1 to 600000000×10 ⁻² [mm/min] inch: 1 to 600000000×10 ⁻³ [inch/min] degree: 1 to 2147483647×10 ⁻³ [degree/min] ⁴ pulse: 1 to 2147483647[pulse/s]	
+ (2V+30R+3)						
+ (2V+30R+4)			[Da.6] Positioning address/Travel value		-2147483648 to 2147483647 [Optional units]	
+ (2V+30R+5)						
+ (2V+30R+6)				[Da. 7] Arc address		-2147483648 to 2147483647 [Optional units]
+ (2V+30R+7)						
+ (2V+30R+8)	Axis 4 data	Axis No.		R64MTCPU: 1 to 64, 1001 to 1064 ^{*2} R32MTCPU: 1 to 32, 1001 to 1032 ^{*2} R16MTCPU: 1 to 16, 1001 to 1016 ^{*2}		
+ (2V+30R+9)		Unusable		0		
+ (2V+30R+10)		Positioning point No.1	[Da.2] Control mode/ [Da.29] Interpolation axis speed designation		☞ Page 46 Positioning point data	
+ (2V+30R+11)				[Da.10] M-code	M-code: 0 to 32767 Number of pitches: 0 to 999	
+ (2V+30R+12)				[Da.11] Dwell time	0 to 5000 [ms]	
+ (2V+30R+13)				Torque limit value during operation*3	1 to 10000 [×0.1%]	
+ (2V+30R+14)				[Da.8] Command speed		mm: 1 to 600000000×10 ⁻² [mm/min] inch: 1 to 600000000×10 ⁻³ [inch/min] degree: 1 to 2147483647×10 ⁻³ [degree/min] ⁴ pulse: 1 to 2147483647[pulse/s]
+ (2V+30R+15)						
+ (2V+30R+16)				[Da.6] Positioning address/Travel value		-2147483648 to 2147483647 [Optional units]
+ (2V+30R+17)						
+ (2V+30R+18)					[Da. 7] Arc address	
+ (2V+30R+19)						
⋮		⋮		⋮		
+ (2V+40R)		Positioning point No.(R)	[Da.2] Control mode/ [Da.29] Interpolation axis speed designation		☞ Page 46 Positioning point data	
+ (2V+40R+1)				[Da.10] M-code	M-code: 0 to 32767 Number of pitches: 0 to 999	
+ (2V+40R+2)				[Da.11] Dwell time	0 to 5000 [ms]	
+ (2V+40R+3)				Torque limit value during operation*3	1 to 10000 [×0.1%]	
+ (2V+40R+4)				[Da.8] Command speed		mm: 1 to 600000000×10 ⁻² [mm/min] inch: 1 to 600000000×10 ⁻³ [inch/min] degree: 1 to 2147483647×10 ⁻³ [degree/min] ⁴ pulse: 1 to 2147483647[pulse/s]
+ (2V+40R+5)						
+ (2V+40R+6)	[Da.6] Positioning address/Travel value				-2147483648 to 2147483647 [Optional units]	
+ (2V+40R+7)						
+ (2V+40R+8)				[Da. 7] Arc address		-2147483648 to 2147483647 [Optional units]
+ (2V+40R+9)						

*1 The "R" and "V" of "+ (2V+10R+3)" in the positioning data area explanation indicate the following items for the offset values.

- R: Positioning point
- V: Positioning data item

Calculate the offset value for each item as follows.

(Example) When positioning data item is "5", and positioning point is "20"

$$+(2V+10R+3) = (2 \times 5 + 10 \times 20 + 3) = +213$$

*2 When using command generation axis

- *3 Only valid during continuous trajectory control, VPF/VPR, VVF/VVR. When setting torque limit in another control mode, set the torque limit value at start in positioning data item. When not using torque limit value during operation, set "0". When both torque limit during operation and torque limit at start are set in VVF/VVR, torque limit at start is valid.
- *4 When the "speed control 10 multiplier speed setting for degree axis" is set to "valid", the setting range is 1 to $2147483647 \times 10^{-2}$ [degree/min]

Processing details

■Controls

- Request a direct positioning start to the Motion CPU from the data stored in the positioning data area of the device of the self CPU specified with (S2) and after.
- It is necessary to take an inter-lock by the start accept flag of CPU buffer memory and user device so that multiple instructions may not be executed toward the same axis of the same Motion CPU No.

Point

Refer to the start accept flag (system area) for details of the start accept flag. (Page 83 Start accept flag (System area))

■Operation

Outline operation between CPUs at the MP.SVSTD and DP.SVSTD instruction execution is shown below.

• MP.SVSTD instruction

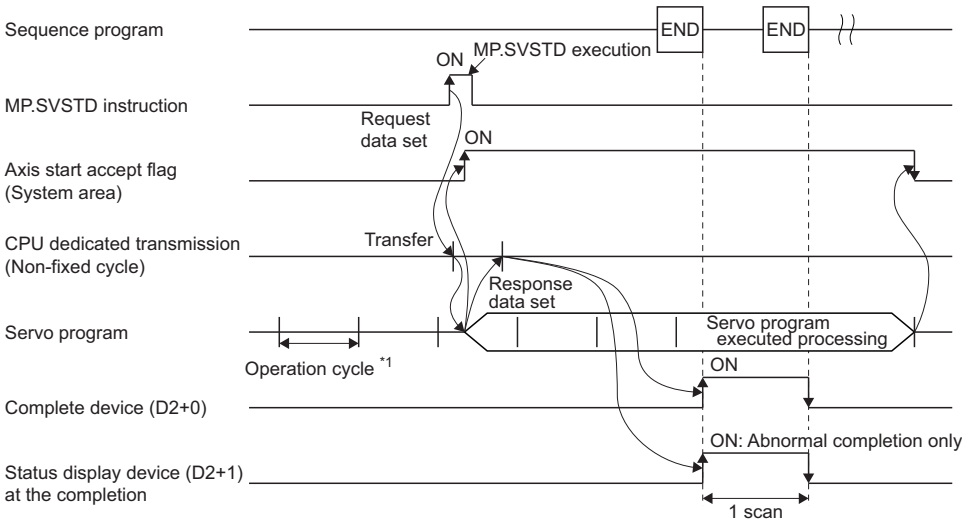

*1 Set in [Motion CPU Common parameter] ⇒ [Basic Setting]

• DP.SVSTD instruction

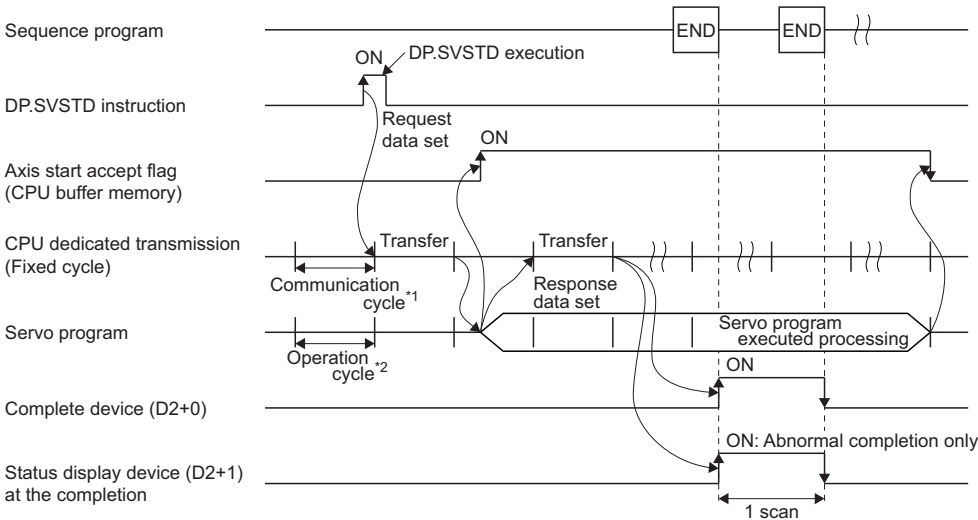

*1 Set in [System Parameter] ⇒ [Multiple CPU settings] in GX Works3

*2 Set in [Motion CPU Common parameter] ⇒ [Basic Setting]

■Positioning type/Number of points

When starting continuous trajectory control (CPSTART), set the number of points for positioning points (1 to 128). The number of positioning points cannot exceed the number of points for the positioning data area (14 to 2044) set in control data (S1 + 1). When starting a control other than continuous trajectory control (CPSTART) set "0". Only one point is set for positioning point.

■Setting of positioning data items

- Set the positioning data items used when executing instructions. Set the bit of the item to be set ON (1: Valid). Items that are OFF (0: Invalid) use the data of parameter block No. 1 for positioning start.

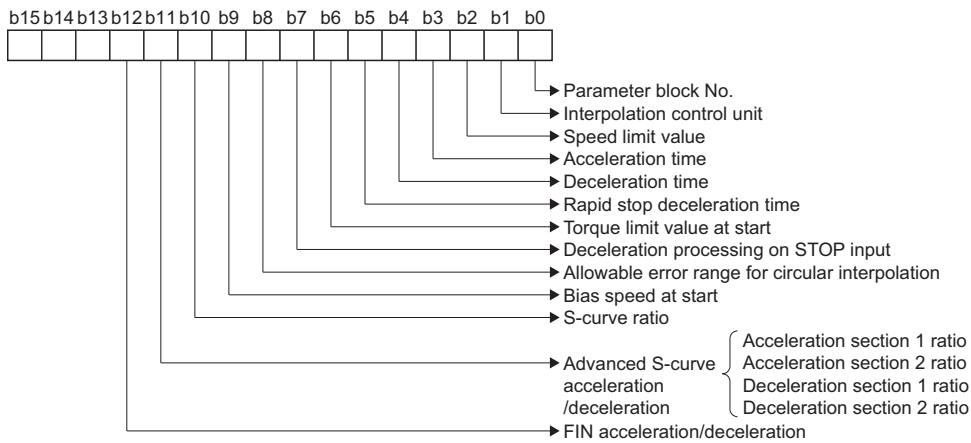

*: Positioning data items setting value is 0 or 1
 • 0: Not possible
 • 1: Possible

- Data that is set to ON (1: Valid) is assigned from "Positioning data item No. 1" in order. Refer to the following for details on data to be set.

📖MELSEC iQ-R Motion controller Programming Manual (Positioning Control)A positioning data item uses two words. However, advanced S-curve acceleration/deceleration uses four items (8 words).

Ex.

When parameter block No., acceleration time, and advanced S-curve acceleration/deceleration are set.

Offset	Name	Setting value
(S2)+1	Setting of positioning data items	0809H
(S2)+2	Positioning data item No.1	Parameter block No.
(S2)+3		
(S2)+4	Positioning data item No.2	Acceleration time
(S2)+5		
(S2)+6	Positioning data item No.3	Advanced S-curve acceleration/deceleration Acceleration section 1 ratio
(S2)+7		
(S2)+8	Positioning data item No.4	Advanced S-curve acceleration/deceleration Acceleration section 2 ratio
(S2)+9		
(S2)+10	Positioning data item No.5	Advanced S-curve acceleration/deceleration Deceleration section 1 ratio
(S2)+11		
(S2)+12	Positioning data item No.6	Advanced S-curve acceleration/deceleration Deceleration section 2 ratio
(S2)+13		

- The data item that can be set is different depending on which control mode is started. When a data item that cannot be used is set, the data item is ignored. Also, when two exclusive data items are set, the later bit item in the setting of positioning data items is prioritized.

Ex.

When S-curve ratio and advanced S-curve acceleration/deceleration are both set, the S-curve ratio item is ignored.

■ Positioning point data

Set "[Da.2] Control mode", and "[Da.29] Interpolation axis speed designation" when performing positioning control.

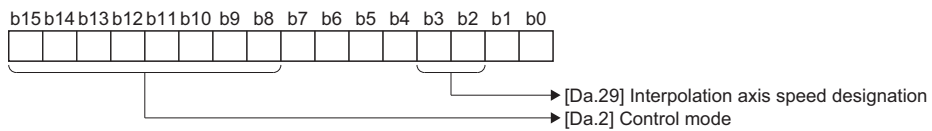

- [Da.29] Interpolation axis speed designation

Setting value	Description
0 or 1	Vector speed
2	Reference axis speed
3	Longest axis speed

• [Da.2] Control mode

Positioning control		Instruction symbol	Control description	Setting value	Remark
Linear interpolation control	1 axis	ABS-1	Absolute 1-axis positioning	01H	<p>■ Interpolation control¹</p> <ul style="list-style-type: none"> When performing interpolation control, set "[Da.2] Control mode" to "NOP" for interpolation axes (axes other than the reference axis) for the data of 1 to 4 axes. For the linear axis for helical interpolation, set "ABS-1" or "INC-1". When control mode settings are wrong, a minor error (error code: 19FCH) occurs, and positioning does not start. <p>■ Continuous trajectory control (CPSTART)</p> <ul style="list-style-type: none"> The control modes that can be set to "[Da.2] Control mode" are linear interpolation control (ABS-1 to 4, INC-1 to 4), circular interpolation control (ABS/INC), and helical interpolation control (ABS/INC). If any other control mode is set, a minor error (error code: 19FCH) occurs, and control does not start. When performing circular interpolation control or helical interpolation control with 3 axes or more in continuous trajectory control, set "[Da.2] Control mode" to "0" for the resting axes (axes that do not apply to interpolation). "[Da.29] Interpolation axis speed designation" setting is ignored and is always controlled at "vector speed".
		INC-1	Incremental 1-axis positioning	02H	
	2 axis	ABS-2	Absolute 2-axis positioning	0AH	
		INC-2	Incremental 2-axis positioning	0BH	
	3 axis	ABS-3	Absolute 3-axis positioning	15H	
		INC-3	Incremental 3-axis positioning	16H	
	4 axis	ABS-4	Absolute 4-axis positioning	1AH	
		INC-4	Incremental 4-axis positioning	1BH	
Circular interpolation control	Auxiliary point-specified	ABS ↻	Absolute auxiliary point-specified circular interpolation	0DH	
		INC ↻	Incremental auxiliary point-specified circular interpolation	0EH	
	Central point-specified	ABS ↻	Absolute central point-specified circular interpolation CW	0FH	
		ABS ↺	Absolute central point-specified circular interpolation CCW	10H	
		INC ↻	Incremental central point-specified circular interpolation CW	11H	
		INC ↺	Incremental central point-specified circular interpolation CCW	12H	
	Radius-specified	ABS ↻	Absolute radius-specified circular interpolation less than CW 180°	30H	
		ABS ↻	Absolute radius-specified circular interpolation CW 180° or more	31H	
		ABS ↺	Absolute radius-specified circular interpolation less than CCW 180°	32H	
		ABS ↺	Absolute radius-specified circular interpolation CCW 180° or more	33H	
		INC ↻	Incremental radius-specified circular interpolation less than CW 180°	34H	
		INC ↻	Incremental radius-specified circular interpolation CW 180° or more	35H	
		INC ↺	Incremental radius-specified circular interpolation less than CCW 180°	36H	
		INC ↺	Incremental radius-specified circular interpolation CCW 180° or more	37H	
	Helical interpolation control	Auxiliary point-specified	ABH ↻	Absolute auxiliary point-specified helical interpolation	20H
			INH ↻	Incremental auxiliary point-specified helical interpolation	21H
		Central point-specified	ABH ↻	Absolute central point-specified helical interpolation CW	22H
			ABH ↺	Absolute central point-specified helical interpolation CCW	23H
INH ↻			Incremental central point-specified helical interpolation CW	24H	
INH ↺			Incremental central point-specified helical interpolation CCW	25H	
Radius-specified		ABH ↻	Absolute radius-specified helical interpolation less than CW 180°	28H	
		ABH ↻	Absolute radius-specified helical interpolation CW 180° or more	29H	
		ABH ↺	Absolute radius-specified helical interpolation less than CCW 180°	2AH	
		ABH ↺	Absolute radius-specified helical interpolation CCW 180° or more	2BH	
		INH ↻	Incremental radius-specified helical interpolation less than CW 180°	2CH	
		INH ↻	Incremental radius-specified helical interpolation CW 180° or more	2DH	
		INH ↺	Incremental radius-specified helical interpolation less than CCW 180°	2EH	
		INH ↺	Incremental radius-specified helical interpolation CCW 180° or more	2FH	

Positioning control		Instruction symbol	Control description	Setting value	Remark
Fixed-Pitch feed control	1 axis	FEED1	1 Axis Fixed-Pitch Feed Control	03H	
	2 axis	FEED2	2-axes linear interpolation fixed-pitch feed control	0CH	
	3 axis	FEED3	3-axes linear interpolation fixed-pitch feed control	17H	
Speed control (I)	Forward rotation	VF	Speed control (I) forward rotation start	04H	
	Reverse rotation	VR	Speed control (I) reverse rotation start	05H	
Speed control (II)	Forward rotation	VVF	Speed control (II) forward rotation start	70H	
	Reverse rotation	VVR	Speed control (II) reverse rotation start	71H	
Speed/position switching control	Forward rotation	VPF	Speed/position switching control forward rotation start	06H	<ul style="list-style-type: none"> VPSTART instruction is not supported. If VPF/VPR instructions are executed by M(P).SVSTD/D(P).SVSTD instructions and VPSTART instruction is executed by the Motion SFC program, a minor error (error code: 19FCH) occurs.
	Reverse rotation	VPR	Speed/position switching control reverse rotation start	07H	
Speed control with fixed position stop	Forward rotation	PVF	Speed control with fixed position stop forward rotation start	73H	<ul style="list-style-type: none"> Set a bit device of the Motion CPU to use for fixed position stop command to (D1). If a valid device is not set to (D1), error code (2225) is stored to the complete status (S1+0), and control does not start. When a number outside the range is set, a minor error (error code: 19FCH) occurs. Acceleration/deceleration time is set by "acceleration time (b4)" of positioning data items setting. If not set, error code (2224) is stored to the complete status (S1+0), and control does not start.
	Reverse rotation	PVR	Speed control with fixed position stop reverse rotation start	74H	
Position follow-up control		PFSTART	Position follow-up control start	75H	Set a word device of the Motion CPU to store the follow-up address to (D1). If a valid device is not set to (D1), error code (2225) is stored to the complete status (S1+0), and control does not start. When a number outside the range is set, a minor error (error code: 19FCH) occurs.
Home position return		ZERO	Home position return start	76H	Home position return is performed based on home position return data. Data other than "[Da.2] Control mode" is ignored.
High speed oscillation		OSC	High-speed oscillation	77H	Set the high speed oscillation setting items (starting angle, amplitude, frequency) to the following positioning point data. <ul style="list-style-type: none"> Amplitude: [Da.6] Positioning address/Travel value Starting angle: [Da.7] Arc address Frequency: [Da.8] Command speed
NOP instruction		NOP	No operation	80H	

*1 The data items set to the reference axis and interpolation axis are shown below.

◎: Must be set

○: Set if required ("—" when not required)

△: "—" or "◎" depending on control mode

—: Setting not required (Setting value is ignored)

Setting item	Setting item for reference axis	Setting item for interpolation axis	Setting item for linear axis for helical interpolation
Same positioning point No.	[Da.2] Control mode	◎	◎ (Set NOP)
	[Da.6] Positioning address/Travel value	◎	◎
	[Da. 7] Arc address	△ (circular interpolation, arc axis of helical interpolation only ◎)	△ (arc axis only ◎)
	[Da.8] Command speed	◎	—
	[Da.10] M-code	○	—
	[Da.11] Dwell time	○	—
	[Da.29] Interpolation axis speed designation	○	—

■Start accept flag (System area)

The complete status of start accept flag is stored in the address of start accept flag in the CPU buffer memory for target CPU.

CPU buffer memory address () is decimal address	Description																														
204H(516) 205H(517) 206H(518) 207H(519)	<p>The start accept flag for 64 axes are stored corresponding to each bit. Bits are actually set as the following:</p> <ul style="list-style-type: none"> • R64MTCPU: J1 to J64 • R32MTCPU: J1 to J32 • R16MTCPU: J1 to J16 <p>OFF: Start accept enable ON: Start accept disable</p> <table border="1"> <thead> <tr> <th></th> <th>b15</th> <th></th> <th>b2</th> <th>b1</th> <th>b0</th> </tr> </thead> <tbody> <tr> <td>204H(516) address</td> <td>J16</td> <td>••••••••</td> <td>J2</td> <td>J1</td> <td></td> </tr> <tr> <td>205H(517) address</td> <td>J32</td> <td>••••••••</td> <td>J18</td> <td>J17</td> <td></td> </tr> <tr> <td>206H(518) address</td> <td>J48</td> <td>••••••••</td> <td>J34</td> <td>J33</td> <td></td> </tr> <tr> <td>207H(519) address</td> <td>J64</td> <td>••••••••</td> <td>J50</td> <td>J49</td> <td></td> </tr> </tbody> </table>		b15		b2	b1	b0	204H(516) address	J16	••••••••	J2	J1		205H(517) address	J32	••••••••	J18	J17		206H(518) address	J48	••••••••	J34	J33		207H(519) address	J64	••••••••	J50	J49	
	b15		b2	b1	b0																										
204H(516) address	J16	••••••••	J2	J1																											
205H(517) address	J32	••••••••	J18	J17																											
206H(518) address	J48	••••••••	J34	J33																											
207H(519) address	J64	••••••••	J50	J49																											
20EH(526) 20FH(527) 210H(528) 211H(529)	<p>The command generation axis start accept flag for 64 axes are stored corresponding to each bit. Bits are actually set as the following:</p> <ul style="list-style-type: none"> • R64MTCPU: J1 to J64 • R32MTCPU: J1 to J32 • R16MTCPU: J1 to J16 <p>OFF: Start accept enable ON: Start accept disable</p> <table border="1"> <thead> <tr> <th></th> <th>b15</th> <th></th> <th>b2</th> <th>b1</th> <th>b0</th> </tr> </thead> <tbody> <tr> <td>20EH(526) address</td> <td>J16</td> <td>••••••••</td> <td>J2</td> <td>J1</td> <td></td> </tr> <tr> <td>20FH(527) address</td> <td>J32</td> <td>••~•••••</td> <td>J18</td> <td>J17</td> <td></td> </tr> <tr> <td>210H(528) address</td> <td>J48</td> <td>••~•••••</td> <td>J34</td> <td>J33</td> <td></td> </tr> <tr> <td>211H(529) address</td> <td>J64</td> <td>••~•••••</td> <td>J50</td> <td>J49</td> <td></td> </tr> </tbody> </table>		b15		b2	b1	b0	20EH(526) address	J16	••••••••	J2	J1		20FH(527) address	J32	••~•••••	J18	J17		210H(528) address	J48	••~•••••	J34	J33		211H(529) address	J64	••~•••••	J50	J49	
	b15		b2	b1	b0																										
20EH(526) address	J16	••••••••	J2	J1																											
20FH(527) address	J32	••~•••••	J18	J17																											
210H(528) address	J48	••~•••••	J34	J33																											
211H(529) address	J64	••~•••••	J50	J49																											

Operation error

- The abnormal completion in the case shown below, and the error code is stored in the device specified with the complete

status storage device (S1+0).

Complete status* ¹ (Error code) (H)	Error factor	Corrective action
0010	Instruction request to Motion CPU from PLC CPU exceeds the permissible value.	Check the sequence program, and correct it.
2100	There are 257 or more simultaneous M(P).SVST/D(P).SVST/M(P).SVSTD/D(P).SVSTD/M(P).CHGA/D(P).CHGA/M(P).CHGAS/D(P).CHGAS/M(P).MCNST/D(P).MCNST instruction requests to the Motion CPU from the PLC CPU, therefore the Motion CPU cannot process them.	
2209	Axis No. set by M(P).SVSTD/D(P).SVSTD instruction is wrong.	
2220	Instruction area for M(P).SVSTD/D(P).SVSTD instructions is not enough. (There are 128 or more instructions in operation by M(P).SVSTD/D(P).SVSTD instructions)	
2221	The positioning data area points for M(P).SVSTD/D(P).SVSTD instruction is wrong.	
2222	Instructions for M(P).SVSTD/D(P).SVSTD instructions are only NOP or resting axes.	
2224	Positioning data items that must be set in instructions by M(P).SVSTD/D(P).SVSTD instructions have not been set.	
2225	Character string data (D1) is wrong in M(P).SVSTD/D(P).SVSTD instructions.	

*1 0000H (Normal)

- An operation error occurs, "Latest self-diagnosis error detection (SM0)" is turned on, and an error code is stored in "Latest self-diagnosis error (SD0)" in the cases shown below.

Error code (H)* ¹	Error factor	Corrective action
2800	The start I/O number (the first 3 digits when expressed in 4-digit hexadecimal) of the specified other CPU module is outside the range of 3E0H to 3E3H.	Check the sequence program, and correct it.
2801	The specified other CPU module is wrong. <ul style="list-style-type: none"> • The reserved CPU is specified. • The uninstalled CPU is specified. 	

*1 0000H (Normal)

Program example

- Program which requests to start direct positioning corresponding to the following servo program in the Motion CPU (CPU No.2), when M0 turned ON

ABS-1		
Axis	1,	100000 pulse
Speed		100000 pulse/s

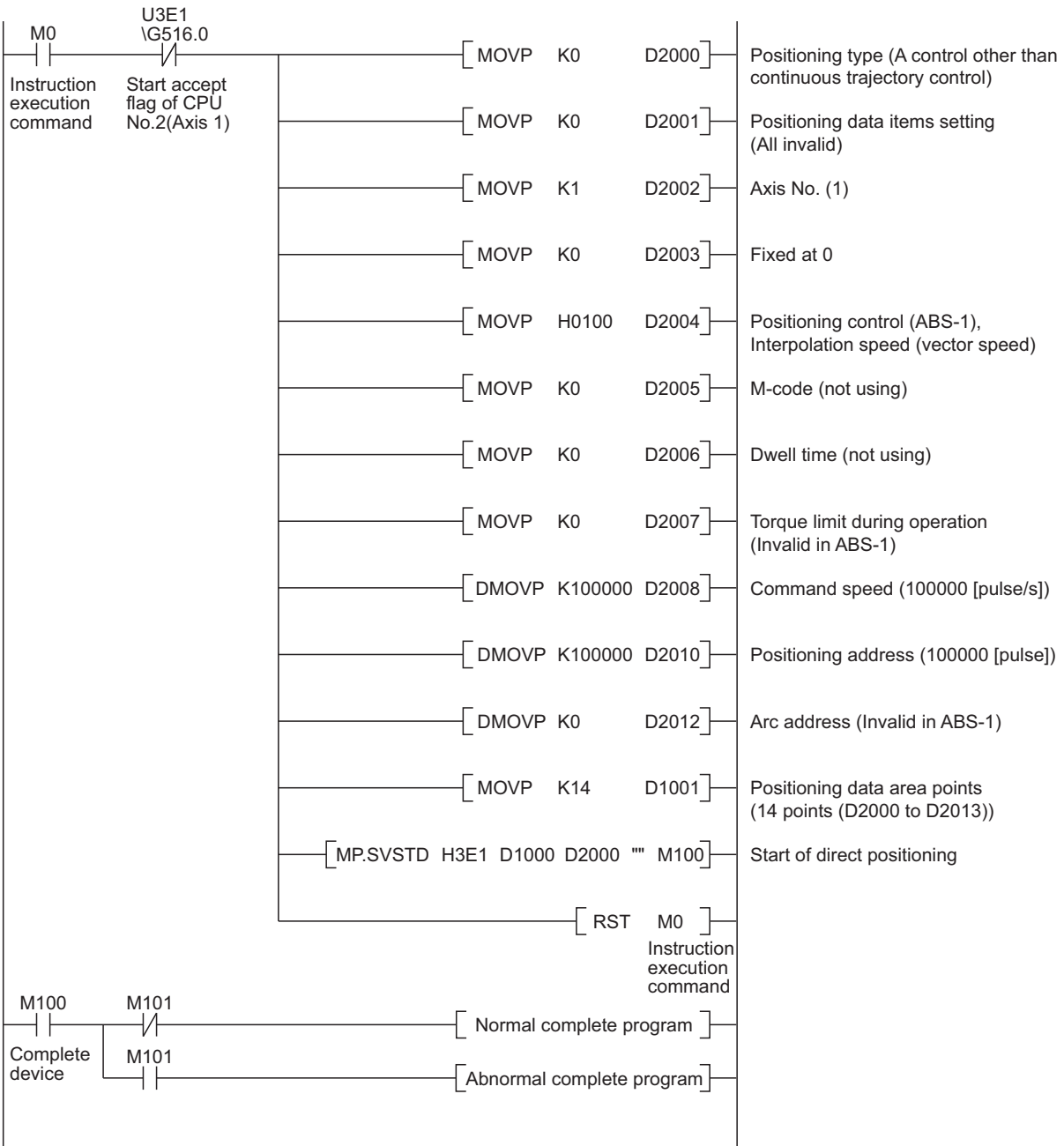

Current value change instruction from the PLC CPU to the Motion CPU: M(P).CHGA/D(P).CHGA

Instruction	Condition	Sequence program*1
MP.CHGA DP.CHGA		Command Command
M.CHGA D.CHGA		Command Command

*1 □: Instruction (M(P).CHGA: M, D(P).CHGA: D)

Setting data

Usable devices

○: Usable, △: Usable partly

Setting data*3	Usable devices											
	Internal devices (System, User)		File register		Link direct device J□\□		Module access device U□\G□		Index register Z□	Constant		Others
	Bit	Word	Bit	Word	Bit	Word	Bit	Word		Decimal K, Hexadecimal H	Real character string	
(n1)		○		○						○		
(S1)		○		○							○	
(n2)		○		○						○		
(D1)*1	△*2		△*2									
(D2)*1		△*2		△*2								

*1 Omission possible with both of (D1) and (D2) omission.

*2 Local devices cannot be used.

*3 Setting data (n1) to (D2): Index qualification possible (except constant)

Description, range, setting side, data type

Setting data	Description	Setting range	Set by	Data type
(n1)	(First I/O No. of the target CPU)/16 Value to specify actually is the following.*2 CPU No.2: 3E1H, CPU No.3: 3E2H, CPU No.4: 3E3H	3E1H to 3E3H	User	16-bit binary
(S1)	Axis No. ("Jn")*3 to execute the current value change. R64MTCPU: J1 to J64 R32MTCPU: J1 to J32 R16MTCPU: J1 to J16	1 to 64	User	Character string
(n2)	Current value to change	-2147483648 to 2147483647	User	32-bit binary
(D1)*1	Complete devices • (D1+0): Device which make turn on for one scan at accept completion of instruction. • (D1+1): Device which make turn on for one scan at accept abnormal completion of instruction. ("D1+0" also turns on at the abnormal completion.)	—	System	Bit
(D2)*1	Complete status storage device	—	System	Bit

*1 Omission possible with both of (D1) and (D2) omission.

*2 Motion CPU cannot be set as CPU No.1 in the Multiple CPU configuration.

*3 "n" shows the numerical value correspond to axis No. (n=1 to 64)

Processing details

■Controls

- The current value change of axis (stopped axis) specified with (S1) is changed to the current value specified with (n2).
- It is necessary to take an inter-lock by the start accept flag and user device of CPU buffer memory so that multiple instructions may not be executed toward the same axis of same Motion CPU.

Point

Refer to the start accept flag (system area) for details of the start accept flag. (Page 83 Start accept flag (System area))

■Operation

Outline operation between CPUs at the MP.CHGA and DP.CHGA instruction execution by specifying "Jn" as Axis No. is shown below.

- MP.CHGA instruction

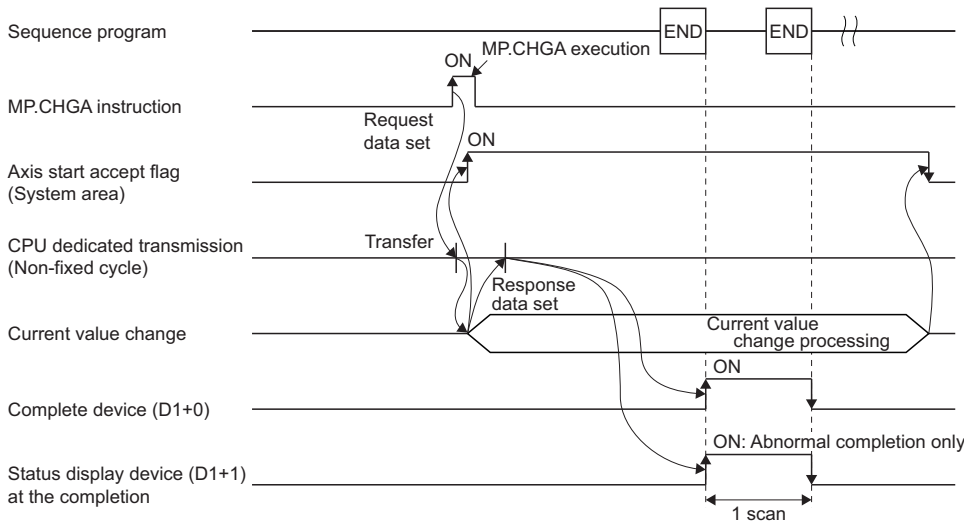

- DP.CHGA instruction

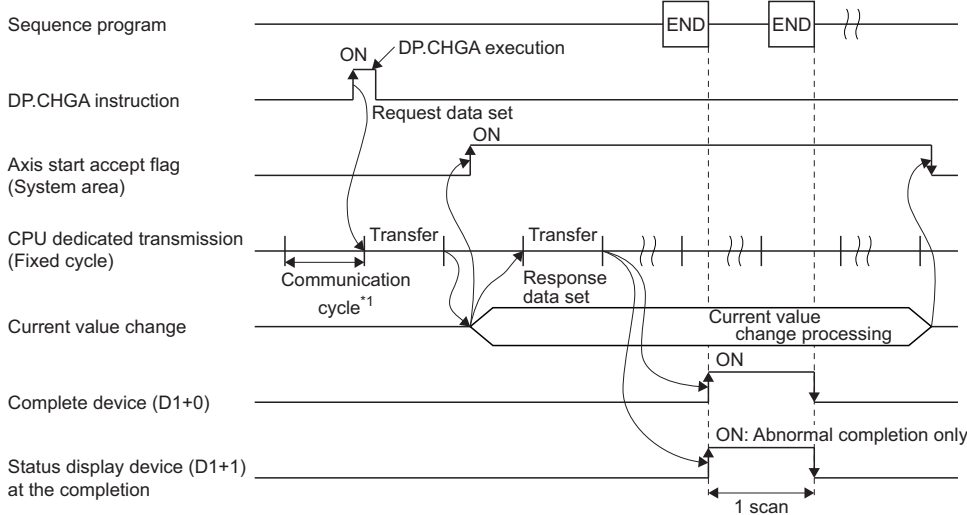

*1 Set in [System Parameter] ⇒ [Multiple CPU settings] in GX Works3

■Setting of axis to execute the current value change

The axis to execute the current value change set as (S1) sets J + Axis No. in a character string " ".

Motion CPU	(S1) usable range
R64MTCPU	1 to 64
R32MTCPU	1 to 32
R16MTCPU	1 to 16

The number of axes which can set are only 1 axis. Set "J" in a capital letter or small letter and use the axis No. set in the servo network setting as the axis No. to start. Refer to the following for servo network settings.

📖 MELSEC iQ-R Motion controller Programming Manual (Common)

■Start accept flag (System area)

When the instruction is executed by specifying "Jn" as Axis No., the complete status of start accept flag is stored in the address of the start accept flag in the CPU buffer memory for target CPU.

CPU buffer memory address () is decimal address	Description																														
204H(516) 205H(517) 206H(518) 207H(519)	<p>The start accept flag for 64 axes are stored corresponding to each bit. Bits are actually set as the following:</p> <ul style="list-style-type: none"> • R64MTCPU: J1 to J64 • R32MTCPU: J1 to J32 • R16MTCPU: J1 to J16 <p>OFF: Start accept enable ON: Start accept disable</p> <table border="1" style="margin-left: auto; margin-right: auto;"> <thead> <tr> <th></th> <th>b15</th> <th></th> <th>b2</th> <th>b1</th> <th>b0</th> </tr> </thead> <tbody> <tr> <td>204H(516) address</td> <td>J16</td> <td>••••••••</td> <td>J2</td> <td>J1</td> <td></td> </tr> <tr> <td>205H(517) address</td> <td>J32</td> <td>••••••••</td> <td>J18</td> <td>J17</td> <td></td> </tr> <tr> <td>206H(518) address</td> <td>J48</td> <td>••••••••</td> <td>J34</td> <td>J33</td> <td></td> </tr> <tr> <td>207H(519) address</td> <td>J64</td> <td>••••••••</td> <td>J50</td> <td>J49</td> <td></td> </tr> </tbody> </table>		b15		b2	b1	b0	204H(516) address	J16	••••••••	J2	J1		205H(517) address	J32	••••••••	J18	J17		206H(518) address	J48	••••••••	J34	J33		207H(519) address	J64	••••••••	J50	J49	
	b15		b2	b1	b0																										
204H(516) address	J16	••••••••	J2	J1																											
205H(517) address	J32	••••••••	J18	J17																											
206H(518) address	J48	••••••••	J34	J33																											
207H(519) address	J64	••••••••	J50	J49																											

Operation error

- The abnormal completion in the case shown below, and the error code is stored in the device specified with the complete status storage device (D2). If the complete status storage device (D2) is omitted, an error is not detected and operation becomes "No operation".

Complete status*1 (Error code) (H)	Error factor	Corrective action
0010	Instruction request to Motion CPU from PLC CPU exceeds the permissible value.	Check the sequence program, and correct it.
2100	There are 257 or more simultaneous M(P).SVST/D(P).SVST/M(P).SVSTD/ D(P).SVSTD/M(P).CHGA/D(P).CHGA/M(P).CHGAS/D(P).CHGAS/ M(P).MCNST/D(P).MCNST instruction requests to the Motion CPU from the PLC CPU, therefore the Motion CPU cannot process them.	
2203	Axis No. set by M(P).CHGA/D(P).CHGA instruction is wrong.	

*1 0000H (Normal)

- An operation error occurs, "Latest self-diagnosis error detection (SM0)" is turned on, and an error code is stored in "Latest self-diagnosis error (SD0)" in the cases shown below.

Error code (H)*1	Error factor	Corrective action
2800	The start I/O number (the first 3 digits when expressed in 4-digit hexadecimal) of the specified other CPU module is outside the range of 3E0H to 3E3H.	Check the sequence program, and correct it.
2801	The specified other CPU module is wrong. <ul style="list-style-type: none"> • The reserved CPU is specified. • The uninstalled CPU is specified. 	

*1 0000H (Normal)

Program example

■ Program which changes the current value to 10 for Axis 1 of the Motion CPU (CPU No.2), when M0 turned ON.

- (Example 1) Program which omits the complete device and complete status.

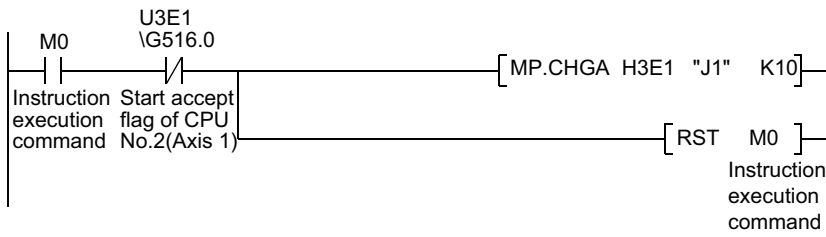

- (Example 2) Program which uses the complete device and complete status.

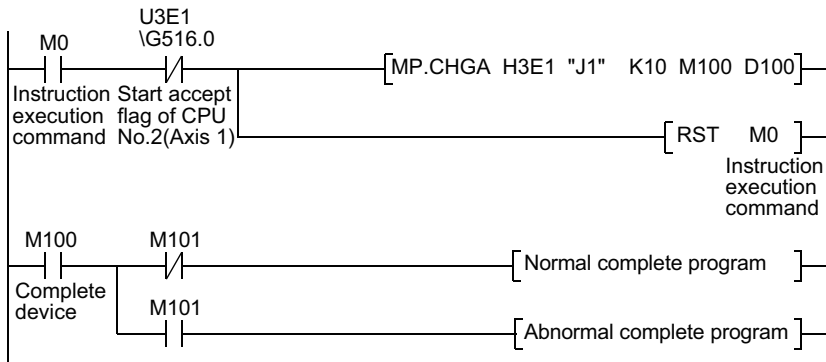

Current value change instruction of command generation axis from the PLC CPU to the Motion CPU: M(P).CHGAS/D(P).CHGAS

Instruction	Condition	Sequence program*1
MP.CHGAS DP.CHGAS		Command Command
M.CHGAS D.CHGAS		Command Command

*1 □: Instruction (M(P).CHGAS: M, D(P).CHGAS: D)

Setting data

Usable devices

○: Usable, △: Usable partly

Setting data*3	Usable devices											
	Internal devices (System, User)		File register		Link direct device J□\□		Module access device U□\G□		Index register Z□	Constant		Others
	Bit	Word	Bit	Word	Bit	Word	Bit	Word		Decimal K, Hexadecimal H	Real character string	
(n1)		○		○						○		
(S1)		○		○							○	
(n2)		○		○						○		
(D1)*1	△*2		△*2									
(D2)*1		△*2		△*2								

*1 Omission possible with both of (D1) and (D2) omission.

*2 Local devices cannot be used.

*3 Setting data (n1) to (D2): Index qualification possible (except constant)

Description, range, setting side, data type

Setting data	Description	Setting range	Set by	Data type
(n1)	(First I/O No. of the target CPU)/16 Value to specify actually is the following.*2 CPU No.2: 3E1H, CPU No.3: 3E2H, CPU No.4: 3E3H	3E1H to 3E3H	User	16-bit binary
(S1)	Axis No. ("Jn")*3 to execute the current value change of command generation axis. R64MTCPU: J1 to J64 R32MTCPU: J1 to J32 R16MTCPU: J1 to J16	1 to 64	User	Character string
(n2)	Current value to change	-2147483648 to 2147483647	User	32-bit binary
(D1)*1	Complete devices • (D1+0): Device which make turn on for one scan at accept completion of instruction. • (D1+1): Device which make turn on for one scan at accept abnormal completion of instruction. ("D1+0" also turns on at the abnormal completion.)	—	System	Bit
(D2)*1	Complete status storage device	—	System	Word

*1 Omission possible with both of (D1) and (D2) omission.

*2 Motion CPU cannot be set as CPU No.1 in the Multiple CPU configuration.

*3 "n" shows the numerical value correspond to axis No. (n=1 to 64)

Processing details

■ Controls

- The current value change of command generation axis (stopped axis) specified with (S1) is changed to the current value specified with (n2).
- It is necessary to take an inter-lock by the start accept flag and user device of CPU buffer memory so that multiple instructions may not be executed toward the same axis of same Motion CPU.

Point

Refer to the start accept flag (system area) for details of the start accept flag. (Page 83 Start accept flag (System area))

■ Operation

Outline operation between CPUs at the MP.CHGAS and DP.CHGAS instruction execution by specifying "Jn" as Axis No. is shown below.

- MP.CHGAS instruction

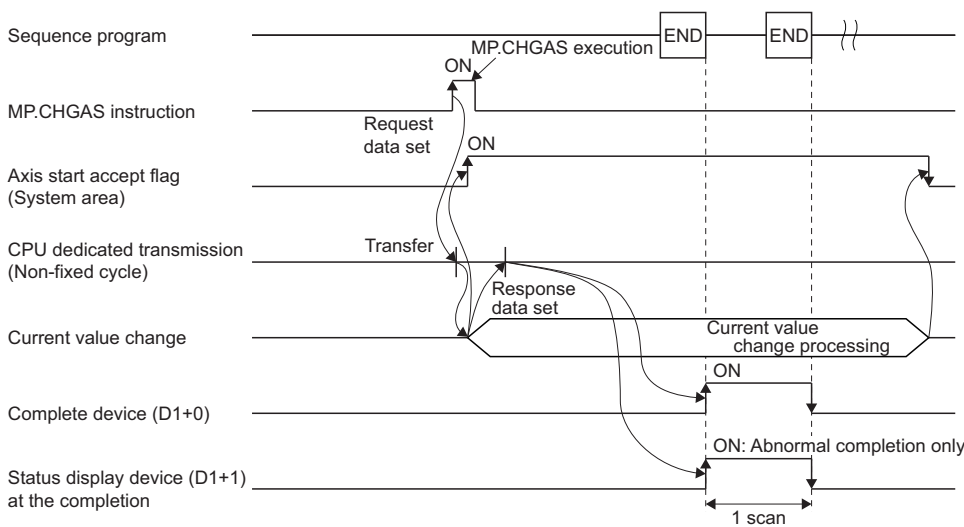

- DP.CHGAS instruction

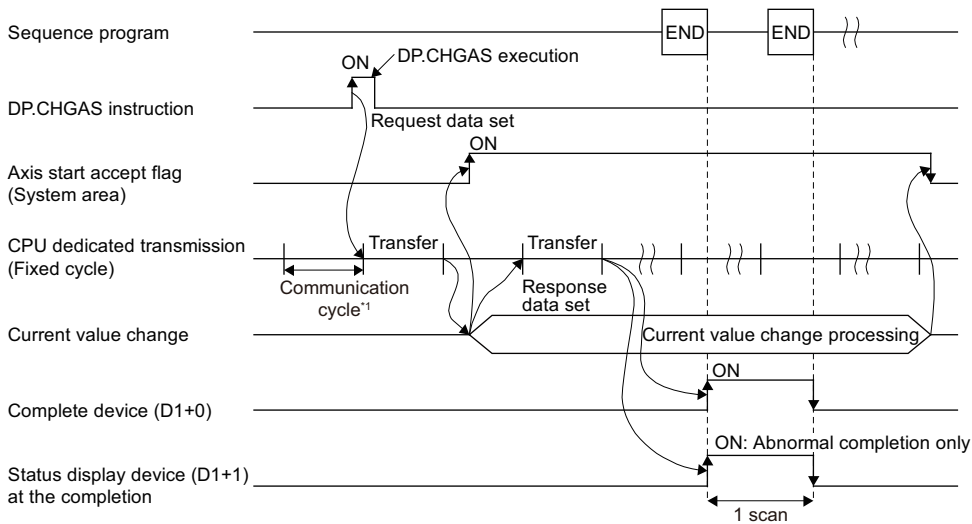

*1 Set in [System Parameter] ⇒ [Multiple CPU settings] in GX Works3

■Setting of axis to execute the current value change

The axis to execute the current value change set as (S1) sets J + Axis No. in a character string " ".

Motion CPU	(S1) usable range
R64MTCPU	1 to 64
R32MTCPU	1 to 32
R16MTCPU	1 to 16

The number of axes which can set are only 1 axis. Set "J" in a capital letter or small letter and use the axis No. set in the command generation axis parameter as the axis No. to start. Refer to the following for command generation axis parameter.

📖MELSEC iQ-R Motion controller Programming Manual (Advanced Synchronous Control)

■Start accept flag (System area)

When the instruction is executed by specifying "Jn" as Axis No., the complete status of start accept flag is stored in the address of the start accept flag in the CPU buffer memory for target CPU.

CPU buffer memory address () is decimal address	Description																														
20EH(526) 20FH(527) 210H(528) 211H(529)	<p>The command generation axis start accept flag for 64 axes are stored corresponding to each bit. Bits are actually set as the following:</p> <ul style="list-style-type: none"> • R64MTCPU: J1 to J64 • R32MTCPU: J1 to J32 • R16MTCPU: J1 to J16 <p>OFF: Start accept enable ON: Start accept disable</p> <table border="1" style="margin-left: auto; margin-right: auto;"> <thead> <tr> <th></th> <th>b15</th> <th></th> <th>b2</th> <th>b1</th> <th>b0</th> </tr> </thead> <tbody> <tr> <td>20EH(526) address</td> <td>J16</td> <td>••••••••</td> <td></td> <td>J2</td> <td>J1</td> </tr> <tr> <td>20FH(527) address</td> <td>J32</td> <td>••••••••</td> <td></td> <td>J18</td> <td>J17</td> </tr> <tr> <td>210H(528) address</td> <td>J48</td> <td>••••••••</td> <td></td> <td>J34</td> <td>J33</td> </tr> <tr> <td>211H(529) address</td> <td>J64</td> <td>••••••••</td> <td></td> <td>J50</td> <td>J49</td> </tr> </tbody> </table>		b15		b2	b1	b0	20EH(526) address	J16	••••••••		J2	J1	20FH(527) address	J32	••••••••		J18	J17	210H(528) address	J48	••••••••		J34	J33	211H(529) address	J64	••••••••		J50	J49
	b15		b2	b1	b0																										
20EH(526) address	J16	••••••••		J2	J1																										
20FH(527) address	J32	••••••••		J18	J17																										
210H(528) address	J48	••••••••		J34	J33																										
211H(529) address	J64	••••••••		J50	J49																										

Operation error

- The abnormal completion in the case shown below, and the error code is stored in the device specified with the complete status storage device (D2). If the complete status storage device (D2) is omitted, an error is not detected and operation becomes "No operation".

Complete status*1 (Error code) (H)	Error factor	Corrective action
0010	Instruction request to Motion CPU from PLC CPU exceeds the permissible value.	Check the sequence program, and correct it.
2100	There are 257 or more simultaneous M(P).SVST/D(P).SVST/M(P).SVSTD/D(P).SVSTD/M(P).CHGA/D(P).CHGA/M(P).CHGAS/D(P).CHGAS/M(P).MCNST/D(P).MCNST instruction requests to the Motion CPU from the PLC CPU, therefore the Motion CPU cannot process them.	
2207	Axis No. set by M(P).CHGAS/D(P).CHGAS instruction is wrong.	

*1 0000H (Normal)

- An operation error occurs, "Latest self-diagnosis error detection (SM0)" is turned on, and an error code is stored in "Latest self-diagnosis error (SD0)" in the cases shown below.

Error code (H)*1	Error factor	Corrective action
2800	The start I/O number (the first 3 digits when expressed in 4-digit hexadecimal) of the specified other CPU module is outside the range of 3E0H to 3E3H.	Check the sequence program, and correct it.
2801	The specified other CPU module is wrong. <ul style="list-style-type: none"> • The reserved CPU is specified. • The uninstalled CPU is specified. 	

*1 0000H (Normal)

Program example

■ Program which changes the current value to 10 for Axis 1 of the Motion CPU (CPU No.2), when M0 turned ON.



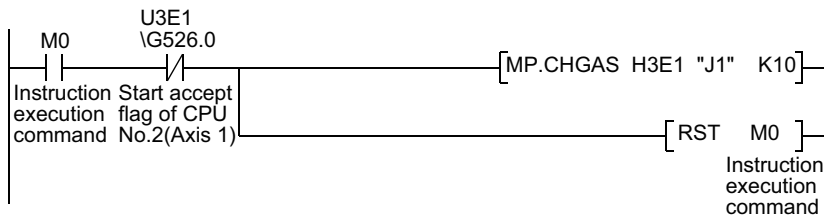

- (Example 1) Program which omits the complete device and complete status.

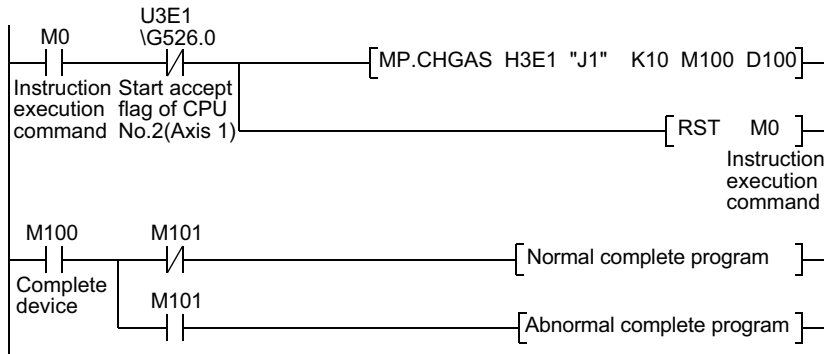

- (Example 2) Program which uses complete device and complete status.

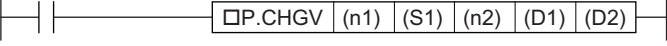

Speed change instruction from the PLC CPU to the Motion CPU: M(P).CHGV/D(P).CHGV

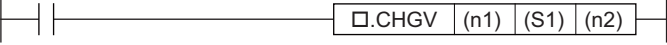
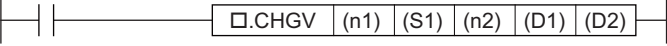
Instruction	Condition	Sequence program*1
MP.CHGV DP.CHGV		Command  Command 
M.CHGV D.CHGV		Command  Command 

*1 □: Instruction (M(P).CHGV: M, D(P).CHGV: D)

Setting data

■Usable devices

○: Usable, △: Usable partly

Setting data*3	Usable devices											
	Internal devices (System, User)		File register		Link direct device J□\□		Module access device U□\G□		Index register Z□	Constant		Others
	Bit	Word	Bit	Word	Bit	Word	Bit	Word		Decimal K, Hexadecimal H	Real character string	
(n1)		○		○						○		
(S1)		○		○							○	
(n2)		○		○						○		
(D1)*1	△*2		△*2									
(D2)*1		△*2		△*2								

*1 Omission possible with both of (D1) and (D2) omission.

*2 Local devices cannot be used.

*3 Setting data (n1) to (D2): Index qualification possible (except constant)

■Description, range, setting side, data type

Setting data	Description	Setting range	Set by	Data type
(n1)	(First I/O No. of the target CPU)/16 Value to specify actually is the following.*2 CPU No.2: 3E1H, CPU No.3: 3E2H, CPU No.4: 3E3H	3E1H to 3E3H	User	16-bit binary
(S1)	Axis No. ("Jn")*3 to execute the speed change. R64MTCPU: J1 to J64 R32MTCPU: J1 to J32 R16MTCPU: J1 to J16	1 to 64	User	Character string
(n2)	Speed to change	*4	User	32-bit binary
(D1)*1	Complete devices • (D1+0): Device which make turn on for one scan at accept completion of instruction. • (D1+1): Device which make turn on for one scan at accept abnormal completion of instruction. ("D1+0" also turns on at the abnormal completion.)	—	System	Bit
(D2)*1	Complete status storage device	—	System	Word

*1 Omission possible with both of (D1) and (D2) omission.

*2 Motion CPU cannot be set as CPU No.1 in the Multiple CPU configuration.

*3 "n" shows the numerical value correspond to axis No. (n=1 to 64)

*4 The setting range of each setting unit for (n2) is shown below.

Unit	(n2) usable range
mm	-600000000 to 600000000 ($\times 10^{-2}$ [mm/min])
inch	-600000000 to 600000000 ($\times 10^{-3}$ [inch/min])
degree	-2147483647 to 2147483647 ($\times 10^{-3}$ [degree/min])*5
pulse	-2147483647 to 2147483647[pulse/s]

*5 When the "speed control 10 × multiplier setting for degree axis" is set to "valid", the setting range is -2147483647 to 2147483647 ($\times 10^{-2}$ [degree/min]).

Processing details

■Controls

- The speed of axis specified with (S1) is changed to the speed specified with (n2) during positioning or JOG operating.
- There is not an interlock signal on the buffer memory during speed change. When the multiple instructions are executed toward the same axis of same Motion CPU, the speed is changed to specified value by last instruction.
- Acceleration/deceleration time at speed change can be changed by setting the acceleration/deceleration time change parameter of the axis specified with (S1). Refer to the following for acceleration/deceleration time change parameter and acceleration/deceleration time change function.

 MELSEC iQ-R Motion controller Programming Manual (Positioning Control)

■ Operation

Outline operation between CPUs at the MP.CHGV and DP.CHGV instruction execution is shown below.

• MP.CHGV instruction

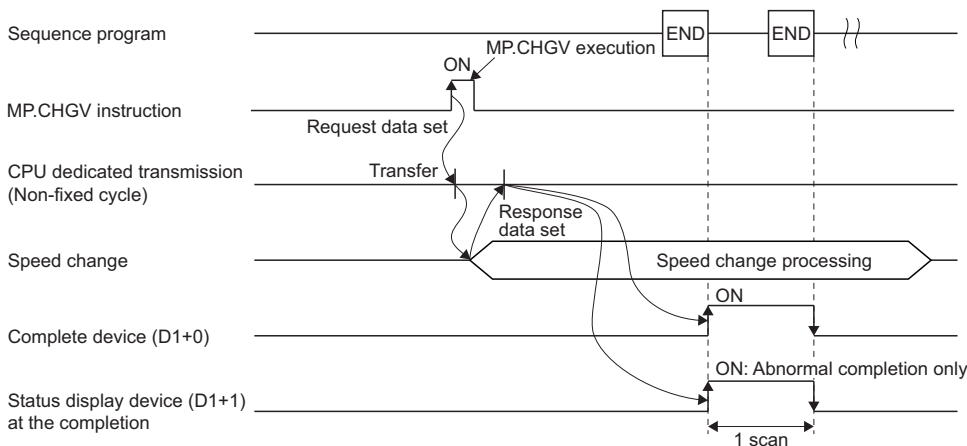

• DP.CHGV instruction

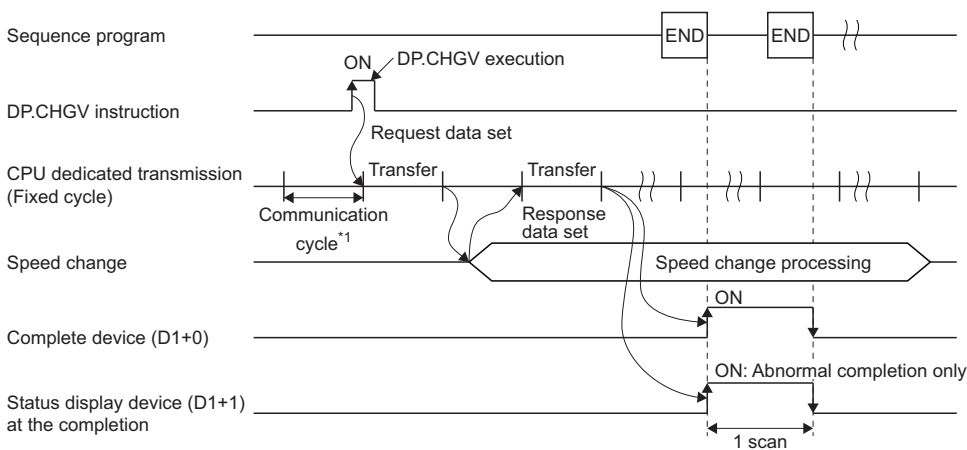

*1 Set in [System Parameter] ⇒ [Multiple CPU settings] in GX Works3

■ Setting of axis to execute the speed change

The axis to execute the speed change set as (S1) sets J + axis No. in a character " ".

Motion CPU	(S1) usable range
R64MTCPU	1 to 64
R32MTCPU	1 to 32
R16MTCPU	1 to 16

The number of axes which can set are only 1 axis. Set "J" in a capital letter or small letter and use the axis No. set in the servo network setting as the axis No. to start. Refer to the following for servo network settings.

📖 MELSEC iQ-R Motion controller Programming Manual (Common)

Operation error

- The abnormal completion in the case shown below, and the error code is stored in the device specified with the complete status storage device (D2). If the complete status storage device (D2) is omitted, an error is not detected and operation becomes "No operation".

Complete status* ¹ (Error code) (H)	Error factor	Corrective action
0010	Instruction request to Motion CPU from PLC CPU exceeds the permissible value.	Check the sequence program, and correct it.
2204	Axis No. set by M(P).CHGV/D(P).CHGV instruction is wrong.	

*1 0000H (Normal)

- An operation error occurs, "Latest self-diagnosis error detection (SM0)" is turned on, and an error code is stored in "Latest self-diagnosis error (SD0)" in the cases shown below.

Error code (H)* ¹	Error factor	Corrective action
2800	The start I/O number (the first 3 digits when expressed in 4-digit hexadecimal) of the specified other CPU module is outside the range of 3E0H to 3E3H.	Check the sequence program, and correct it.
2801	The specified other CPU module is wrong. <ul style="list-style-type: none"> The reserved CPU is specified. The uninstalled CPU is specified. 	

*1 0000H (Normal)

Program example

■Program which changes the positioning speed to 20000 for Axis 1 of the Motion CPU (CPU No.2), when M0 turned ON.

- (Example 1) Program which omits the complete device and complete status.

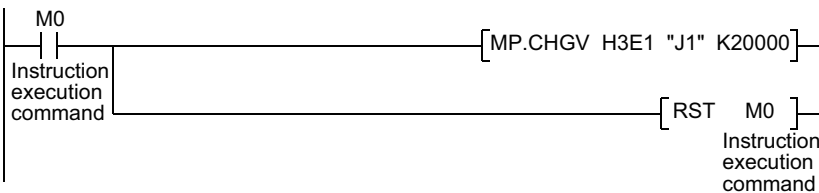

- (Example 2) Program which uses the complete device and complete status.

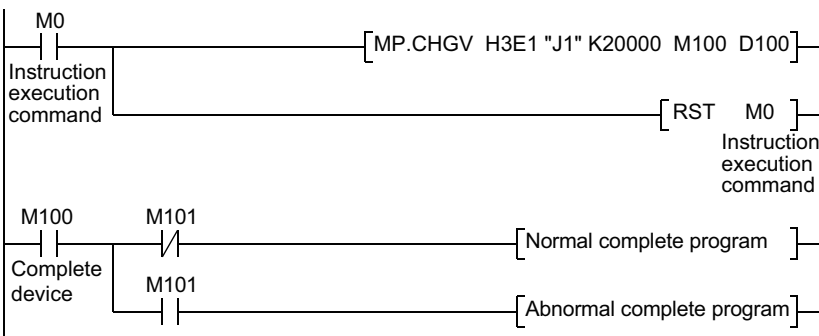

■ Program which changes the positioning speed to 200000 for Axis 1 of the Motion CPU (CPU No.2), when M0 that sets Axis No. as indirect setting method turned ON, and then changes the positioning speed to 50000 for Axis 2, M1 turned ON

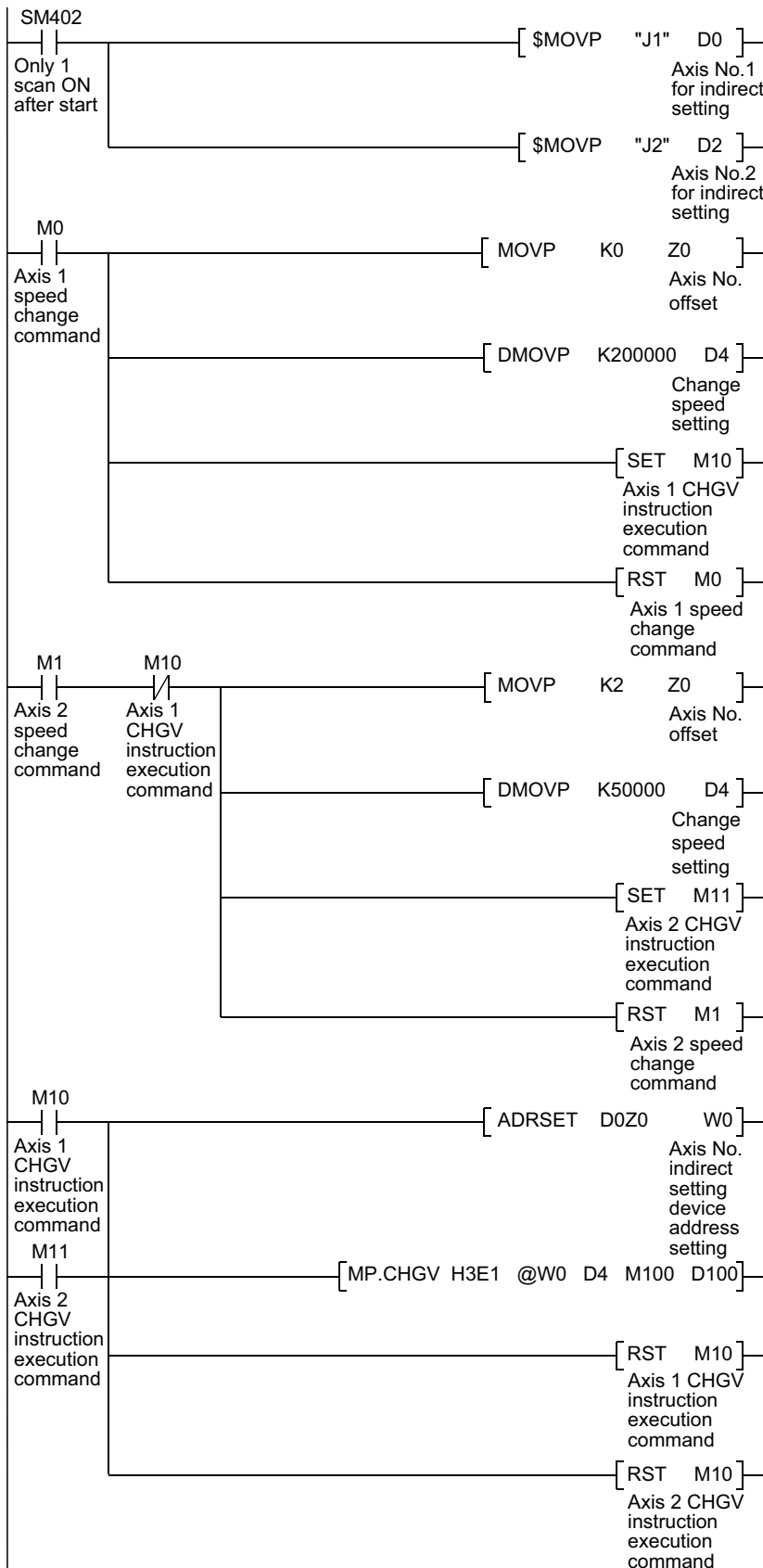

Speed change instruction of command generation axis from the PLC CPU to the Motion CPU: M(P).CHGVS/D(P).CHGVS

Instruction	Condition	Sequence program ^{*1}
MP.CHGVS DP.CHGVS		Command Command
M.CHGVS D.CHGVS		Command Command

*1 □: Instruction (M(P).CHGVS: M, D(P).CHGVS: D)

Setting data

Usable devices

○: Usable, △: Usable partly

Setting data ^{*3}	Usable devices											
	Internal devices (System, User)		File register		Link direct device J□\□		Module access device U□\G□		Index register Z□	Constant		Others
	Bit	Word	Bit	Word	Bit	Word	Bit	Word		Decimal K, Hexadecimal H	Real character string	
(n1)		○		○						○		
(S1)		○		○							○	
(n2)		○		○						○		
(D1) ^{*1}	△ ^{*2}		△ ^{*2}									
(D2) ^{*1}		△ ^{*2}		△ ^{*2}								

*1 Omission possible with both of (D1) and (D2) omission.

*2 Local devices cannot be used.

*3 Setting data (n1) to (D2): Index qualification possible (except constant)

■Description, range, setting side, data type

Setting data	Description	Setting range	Set by	Data type
(n1)	(First I/O No. of the target CPU)/16 Value to specify actually is the following.*2 CPU No.2: 3E1H, CPU No.3: 3E2H, CPU No.4: 3E3H	3E1H to 3E3H	User	16-bit binary
(S1)	Axis No. ("Jn")*3 to execute the speed change. R64MTCPU: J1 to J64 R32MTCPU: J1 to J32 R16MTCPU: J1 to J16	1 to 64	User	Character string
(n2)	Speed to change	*4	User	32-bit binary
(D1)*1	Complete devices • (D1+0): Device which make turn on for one scan at accept completion of instruction. • (D1+1): Device which make turn on for one scan at accept abnormal completion of instruction. ("D1+0" also turns on at the abnormal completion.)	—	System	Bit
(D2)*1	Complete status storage device	—	System	Word

*1 Omission possible with both of (D1) and (D2) omission.

*2 Motion CPU cannot be set as CPU No.1 in the Multiple CPU configuration.

*3 "n" shows the numerical value correspond to axis No. (n=1 to 64)



*4 The setting range of each setting unit for (n2) is shown below.

Unit	(n2) usable range
mm	-600000000 to 600000000 ($\times 10^{-2}$ [mm/min])
inch	-600000000 to 600000000 ($\times 10^{-3}$ [inch/min])
degree	-2147483647 to 2147483647 ($\times 10^{-3}$ [degree/min])*5
pulse	-2147483647 to 2147483647[pulse/s]

*5 When the "speed control 10 × multiplier setting for degree axis" is set to "valid", the setting range is -2147483647 to 2147483647 ($\times 10^{-2}$ [degree/min]).

Processing details

■Controls

- The speed of command generation axis specified with (S1) is changed to the speed specified with (n2) during positioning or JOG operating.
- There is not an interlock signal on the buffer memory during speed change. When the multiple instructions are executed toward the same axis of same Motion CPU, the speed is changed to specified value by last instruction.
- Acceleration/deceleration time at speed change can be changed by setting the acceleration/deceleration time change parameter of the axis specified with (S1). Refer to the following for acceleration/deceleration time change parameter.
 MELSEC iQ-R Motion controller Programming Manual (Advanced Synchronous Control) Refer to the following for acceleration/deceleration time change function.
 MELSEC iQ-R Motion controller Programming Manual (Positioning Control)

■Operation

Outline operation between CPUs at the MP.CHGVS and DP.CHGVS instruction execution is shown below.

• MP.CHGVS instruction

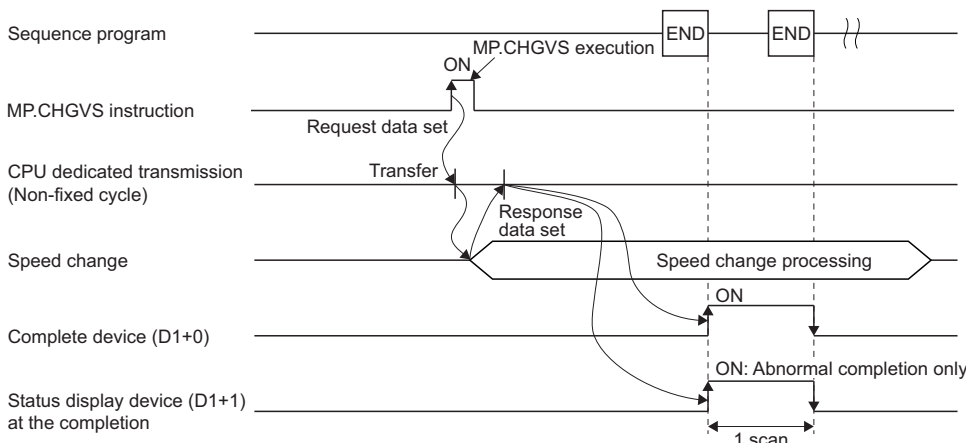

• DP.CHGVS instruction

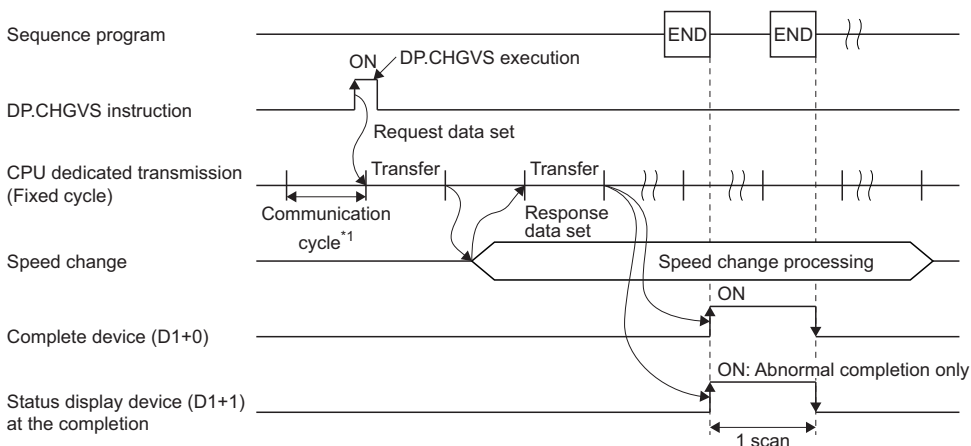

*1 Set in [System Parameter] ⇒ [Multiple CPU settings] in GX Works3

■Setting of axis to execute the speed change

The axis to execute the speed change set as (S1) sets J + axis No. in a character string " ".

Motion CPU	(S1) usable range
R64MTCPU	1 to 64
R32MTCPU	1 to 32
R16MTCPU	1 to 16

The number of axes which can set are only 1 axis. Set "J" in a capital letter or small letter and use the axis No. set in the command generation axis parameter as the axis No. to start. Refer to the following for command generation axis parameter.

📖MELSEC iQ-R Motion controller Programming Manual (Advanced Synchronous Control)

Operation error

- The abnormal completion in the case shown below, and the error code is stored in the device specified with the complete status storage device (D2). If the complete status storage device (D2) is omitted, an error is not detected and operation becomes "No operation".

Complete status* ¹ (Error code) (H)	Error factor	Corrective action
0010	Instruction request to Motion CPU from PLC CPU exceeds the permissible value.	Check the sequence program, and correct it.
2208	Axis No. set by M(P).CHGVS/D(P).CHGVS instruction is wrong.	

*1 0000H (Normal)

- An operation error occurs, "Latest self-diagnosis error detection (SM0)" is turned on, and an error code is stored in "Latest self-diagnosis error (SD0)" in the cases shown below.

Error code (H)* ¹	Error factor	Corrective action
2800	The start I/O number (the first 3 digits when expressed in 4-digit hexadecimal) of the specified other CPU module is outside the range of 3E0H to 3E3H.	Check the sequence program, and correct it.
2801	The specified other CPU module is wrong. <ul style="list-style-type: none"> The reserved CPU is specified. The uninstalled CPU is specified. 	

*1 0000H (Normal)

Program example

■ Program which changes the positioning speed of 20000 for Axis 1 of the Motion CPU (CPU No.2), when M0 turned ON

- (Example 1) Program which omits the complete device and complete status.

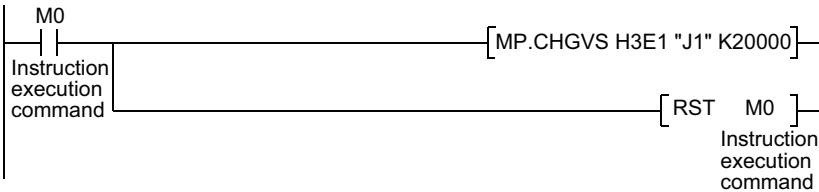

- (Example 2) Program which uses the complete device and complete status.

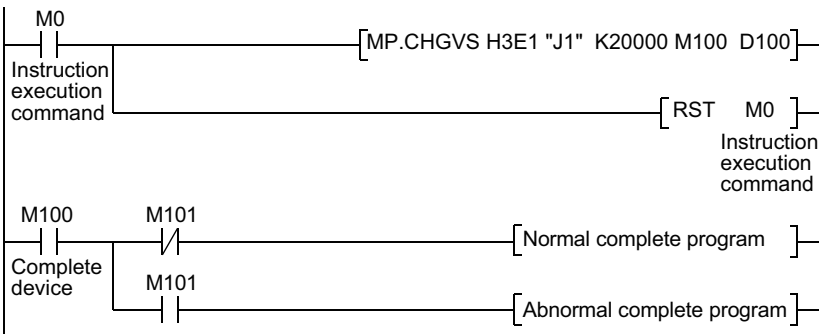

■ Program which changes the positioning speed to 200000 for Axis 1 of the Motion CPU (CPU No.2), when M0 that sets Axis No. as indirect setting method turned ON, and then changes the positioning speed to 50000 for Axis 2, when M1 turned ON

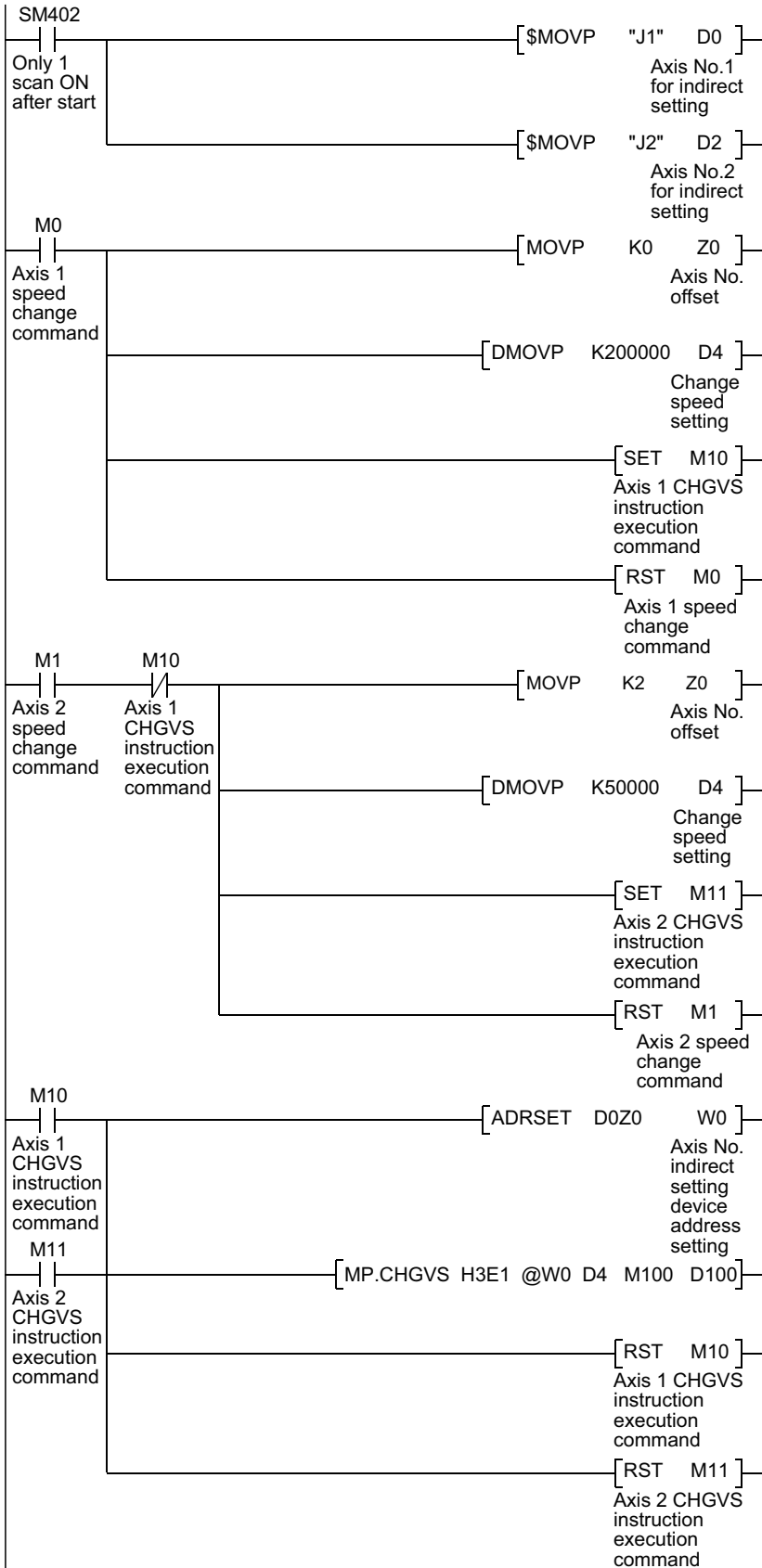

Torque limit value change request instruction from the PLC CPU to the Motion CPU: M(P).CHGT/D(P).CHGT

Instruction	Condition	Sequence program*1
MP.CHGT DP.CHGT		Command Command
M.CHGT D.CHGT		Command Command

*1 □: Instruction (M(P).CHGT: M, D(P).CHGT: D)

Setting data

Usable devices

○: Usable, △: Usable partly

Setting data*3	Usable devices											
	Internal devices (System, User)		File register		Link direct device J□\□		Module access device U□\G□		Index register Z□	Constant		Others
	Bit	Word	Bit	Word	Bit	Word	Bit	Word		Decimal K, Hexadecimal H	Real character string	
(n1)		○		○						○		
(S1)		○		○							○	
(n2)		○		○						○		
(n3)		○		○						○		
(D1)*1	△*2		△*2									
(D2)*1		△*2		△*2								

*1 Omission possible with both of (D1) and (D2) omission.

*2 Local devices cannot be used.

*3 Setting data (n1) to (D2): Index qualification possible (except constant)

Description, range, setting side, data type

Setting data	Description	Setting range	Set by	Data type
(n1)	(First I/O No. of the target CPU)/16 Value to specify actually is the following.*3 CPU No.2: 3E1H, CPU No.3: 3E2H, CPU No.4: 3E3H	3E1H to 3E3H	User	16-bit binary
(S1)	Axis No. ("Jn")*4 to execute the torque limit value change. R64MTCPU: J1 to J64 R32MTCPU: J1 to J32 R16MTCPU: J1 to J16	1 to 64	User	Character string
(n2)*1	Positive direction torque limit value to change (×0.1[%])	1 to 10000 (×0.1[%])	User	16-bit binary
(n3)*1	Negative direction torque limit value to change (×0.1[%])	1 to 10000 (×0.1[%])	User	16-bit binary
(D1)*2	Complete devices • (D1+0): Device which make turn on for one scan at accept completion of instruction. • (D1+1): Device which make turn on for one scan at accept abnormal completion of instruction. ("D1+0" also turns on at the abnormal completion.)	—	System	Bit
(D2)*2	Complete status storage device	—	System	Word

*1 When changing the positive direction/negative direction torque limit value is not necessary, the previous torque limit value can be continued for the set direction by setting -1.

*2 Omission possible with both of (D1) and (D2) omission.

*3 Motion CPU cannot be set as CPU No.1 in the Multiple CPU configuration.

*4 "n" shows the numerical value correspond to axis No. (n=1 to 64)

Processing details

■Controls

- The torque limit value of axis specified with (S1) is changed to the positive direction torque limit value specified with (n2) and negative direction torque limit value specified with (n3) regardless of while being operating or stopping.
- There is not an interlock signal for status of axis torque change. When the multiple instructions are executed toward the same axis of same Motion CPU, the torque is changed to specified value by last instruction.
- Refer to the following for relation between torque limit value specified with servo program and torque limit value change instruction.

📖MELSEC iQ-R Motion controller Programming Manual (Positioning Control)

■Operation

Outline operation between CPUs at the MP.CHGT and DP.CHGT instruction execution is shown below.

- MP.CHGT instruction

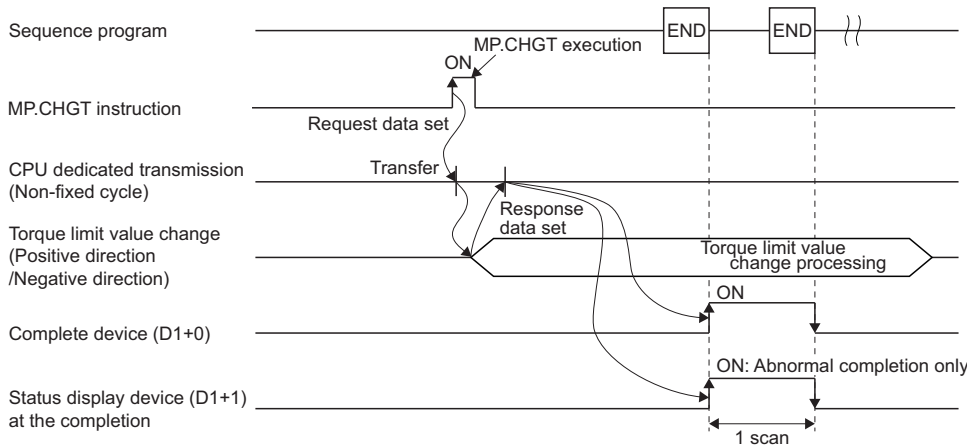

- DP.CHGT instruction

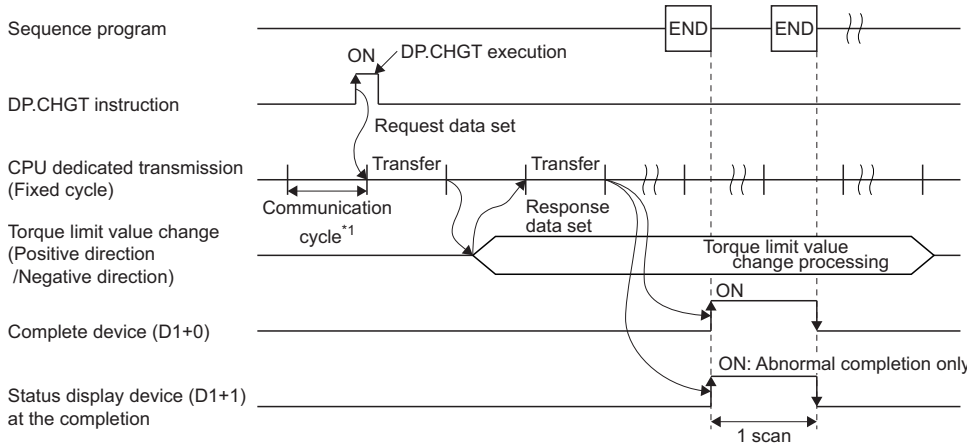

*1 Set in [System Parameter] ⇒ [Multiple CPU settings] in GX Works3

■Setting of axis to execute the torque limit value change

The axis to execute the torque limit change set as (S1) sets J + axis No. in a character string " ".

Motion CPU	(S1) usable range
R64MTCPU	1 to 64
R32MTCPU	1 to 32
R16MTCPU	1 to 16

The number of axes which can set are only 1 axis. Set "J" in a capital letter or small letter and use the axis No. set in the servo network setting as the axis No. to start. Refer to the following for servo network settings.

📖MELSEC iQ-R Motion controller Programming Manual (Common)

Operation error

- The abnormal completion in the case shown below, and the error code is stored in the device specified with the complete status storage device (D2). If the complete status storage device (D2) is omitted, an error is not detected and operation becomes "No operation".

Complete status*1 (Error code) (H)	Error factor	Corrective action
0010	Instruction request to Motion CPU from PLC CPU exceeds the permissible value.	Check the sequence program, and correct it.
2205	Axis No. set by M(P).CHGT/D(P).CHGT instruction is wrong.	

*1 0000H (Normal)

- An operation error occurs, "Latest self-diagnosis error detection (SM0)" is turned on, and an error code is stored in "Latest self-diagnosis error (SD0)" in the cases shown below.

Error code (H)*1	Error factor	Corrective action
2800	The start I/O number (the first 3 digits when expressed in 4-digit hexadecimal) of the specified other CPU module is outside the range of 3E0H to 3E3H.	Check the sequence program, and correct it.
2801	The specified other CPU module is wrong. <ul style="list-style-type: none"> The reserved CPU is specified. The uninstalled CPU is specified. 	

*1 0000H (Normal)

Program example

■ Program which changes the positive torque limit value to 10.0[%] and negative torque limit value to 20.0[%] for Axis 1 of the Motion CPU (CPU No.2), when M0 turned ON

- (Example 1) Program which omits the complete device and complete status.

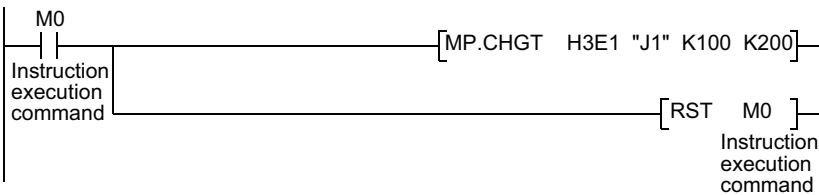

- (Example 2) Program which uses the complete device and complete status.

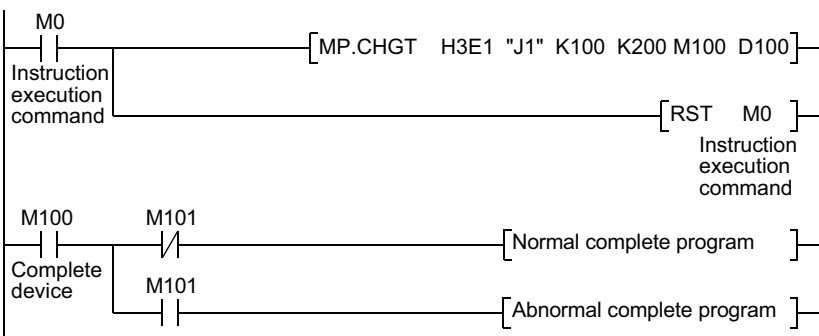

Machine program operation start request from the PLC CPU to the Motion CPU: M(P).MCNST/D(P).MCNST

Instruction	Condition	Sequence program ^{*1}
MP.MCNST		Command
DP.MCNST		
M.MCNST		Command
D.MCNST		

*1 □: Instruction (M(P).MCNST: M, D(P).MCNST: D)

Setting data

■Usable devices

○: Usable, △: Usable partly

Setting data ^{*2}	Usable devices											
	Internal devices (System, User)		File register		Link direct device J□\□		Module access device U□\G□		Index register Z□	Constant		Others
	Bit	Word	Bit	Word	Bit	Word	Bit	Word		Decimal K, Hexadecimal H	Real character string	
(n1)		○		○						○		
(S1)		△ ^{*1}		△ ^{*1}								
(S2)		○		○								
(D1)	△ ^{*1}		△ ^{*1}									

*1 Local devices cannot be used.

*2 Setting data (n1) to (D1): Index qualification possible (except constant)

■Description, range, setting side, data type

Setting data	Description	Setting range	Set by	Data type
(n1)	(First I/O No. of the target CPU)/16 Value to specify actually is the following. ^{*1} CPU No.2: 3E1H, CPU No.3: 3E2H, CPU No.4: 3E3H	3E1H to 3E3H	User	16-bit binary
(S1)	First device of the self CPU where the control data is stored.	—	User	Word
(S2)	First device of the self CPU where the machine positioning data area is stored.	—	User	Word
(D1)	Complete devices • (D1+0): Device which make turn on for one scan at accept completion of instruction. • (D1+1): Device which make turn on for one scan at accept abnormal completion of instruction. ("D2+0" also turns on at the abnormal completion.)	—	System	Bit

*1 Motion CPU cannot be set as CPU No.1 in the Multiple CPU configuration.

■Control data

Device (S1)	Item	Setting data	Setting range	Set by
+0	Complete status	The status at the instruction completion is stored. 0: No error (Normal completion) Except 0: Error code	—	System
+1	Number of machine positioning data points	Set the size of the machine positioning data area in units of words.	78 to 5444	User

■Machine positioning data area

Refer to the following for the machine positioning data area.

📖 MELSEC iQ-R Motion Controller Programming Manual (Machine Control)

Processing details

■ Controls

- Request a machine program operation start to the Motion CPU from the data stored in the machine positioning data area of the device of the self CPU specified with (S2) and after.
- It is necessary to take an inter-lock by the start accept flag of CPU buffer memory and user device so that multiple instructions may not be executed toward the same axis of the same Motion CPU No.

Point

Refer to the start accept flag (system area) for details of the start accept flag. (☞ Page 83 Start accept flag (System area))

■ Operation

Outline operation between CPUs at the MP.MCNST and DP.MCNST instruction execution is shown below.

- MP.MCNST instruction

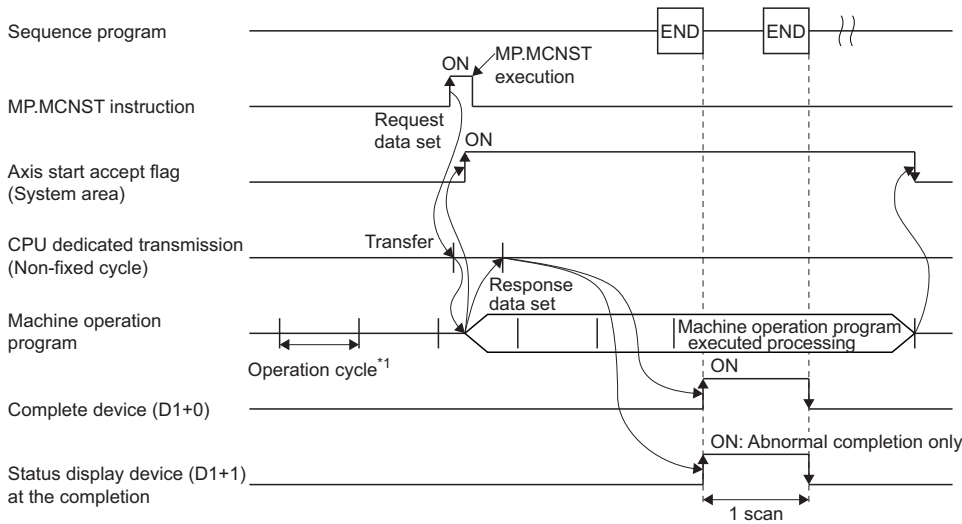

*1 Set in [Motion CPU Common parameter] ⇨ [Basic Setting]

- DP.MCNST instruction

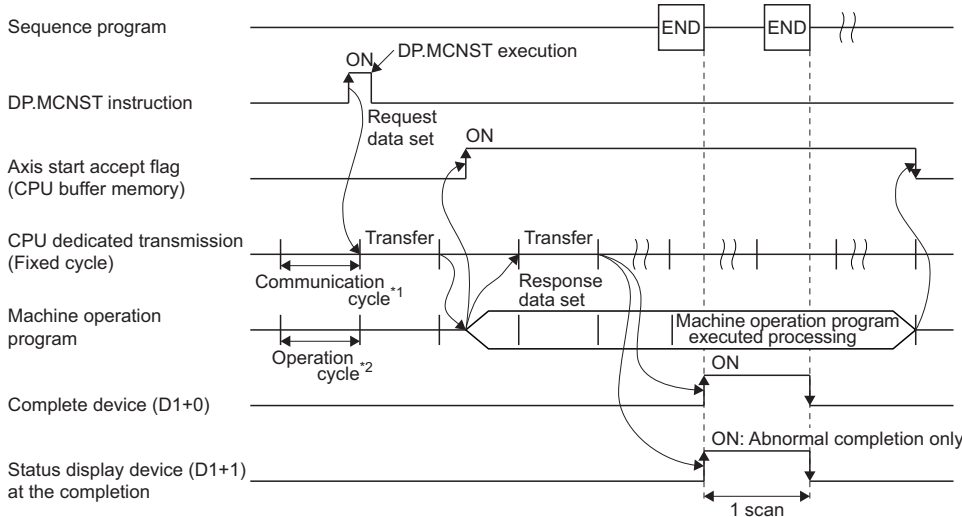

*1 Set in [System Parameter] ⇨ [Multiple CPU settings] in GX Works3

*2 Set in [Motion CPU Common parameter] ⇨ [Basic Setting]

■ Start accept flag (System area)

The complete status of start accept flag is stored in the address of start accept flag in the CPU buffer memory for target CPU.

CPU buffer memory address () is decimal address	Description																									
204H(516) 205H(517) 206H(518) 207H(519)	<p>The start accept flag for 64 axes are stored corresponding to each bit. Bits are actually set as the following:</p> <ul style="list-style-type: none"> • R64MTCPU: J1 to J64 • R32MTCPU: J1 to J32 • R16MTCPU: J1 to J16 <p>OFF: Start accept enable ON: Start accept disable</p> <table border="1"> <thead> <tr> <th></th> <th>b15</th> <th>b2</th> <th>b1</th> <th>b0</th> </tr> </thead> <tbody> <tr> <td>204H(516) address</td> <td>J16</td> <td>••••••••</td> <td>J2</td> <td>J1</td> </tr> <tr> <td>205H(517) address</td> <td>J32</td> <td>••••••••</td> <td>J18</td> <td>J17</td> </tr> <tr> <td>206H(518) address</td> <td>J48</td> <td>••••••••</td> <td>J34</td> <td>J33</td> </tr> <tr> <td>207H(519) address</td> <td>J64</td> <td>••••••••</td> <td>J50</td> <td>J49</td> </tr> </tbody> </table>		b15	b2	b1	b0	204H(516) address	J16	••••••••	J2	J1	205H(517) address	J32	••••••••	J18	J17	206H(518) address	J48	••••••••	J34	J33	207H(519) address	J64	••••••••	J50	J49
	b15	b2	b1	b0																						
204H(516) address	J16	••••••••	J2	J1																						
205H(517) address	J32	••••••••	J18	J17																						
206H(518) address	J48	••••••••	J34	J33																						
207H(519) address	J64	••••••••	J50	J49																						

Operation error

- The abnormal completion in the case shown below, and the error code is stored in the device specified with the complete status storage device (S1+0).

Complete status* ¹ (Error code) (H)	Error factor	Corrective action
0010	Instruction request to Motion CPU from PLC CPU exceeds the permissible value.	Check the sequence program, and correct it.
2100	There are 257 or more simultaneous M(P).SVST/D(P).SVST/M(P).SVSTD/D(P).SVSTD/M(P).CHGA/D(P).CHGA/M(P).CHGAS/D(P).CHGAS/M(P).MCNST/D(P).MCNST instruction requests to the Motion CPU from the PLC CPU, therefore the Motion CPU cannot process them.	
2240	Instruction area for M(P).MCNST/D(P).MCNST instructions is not enough. (There are 9 or more instructions in operation by the Motion dedicated PLC instructions (M(P).MCNST/D(P).MCNST) and Motion dedicated function (MCNST))	
2241	The machine positioning data area setting for M(P).MCNST/D(P).MCNST instruction is wrong.	
2242	The control method for each point of the M(P).MCNST/D(P).MCNST instruction is wrong. (Includes when the control method for every point is NOP only)	
2243	Machine No. set by M(P).MCNST/D(P).MCNST instruction is wrong.	

*1 0000H (Normal)

- An operation error occurs, "Latest self-diagnosis error detection (SM0)" is turned on, and an error code is stored in "Latest self-diagnosis error (SD0)" in the cases shown below.

Error code (H)* ¹	Error factor	Corrective action
2800	The start I/O number (the first 3 digits when expressed in 4-digit hexadecimal) of the specified other CPU module is outside the range of 3E0H to 3E3H.	Check the sequence program, and correct it.
2801	The specified other CPU module is wrong. <ul style="list-style-type: none"> • The reserved CPU is specified. • The uninstalled CPU is specified. 	
2802	The other CPU module does not support M(P).MCNST/D(P).MCNST instructions.	

*1 0000H (Normal)

Program example

■ Program for machine program start request which performs linear interpolation to positioning point P100 at a command speed of 10000 for the machine 1 that consists of axis 1 and axis 2, by the Motion CPU (CPU No.2), when M0 turned ON

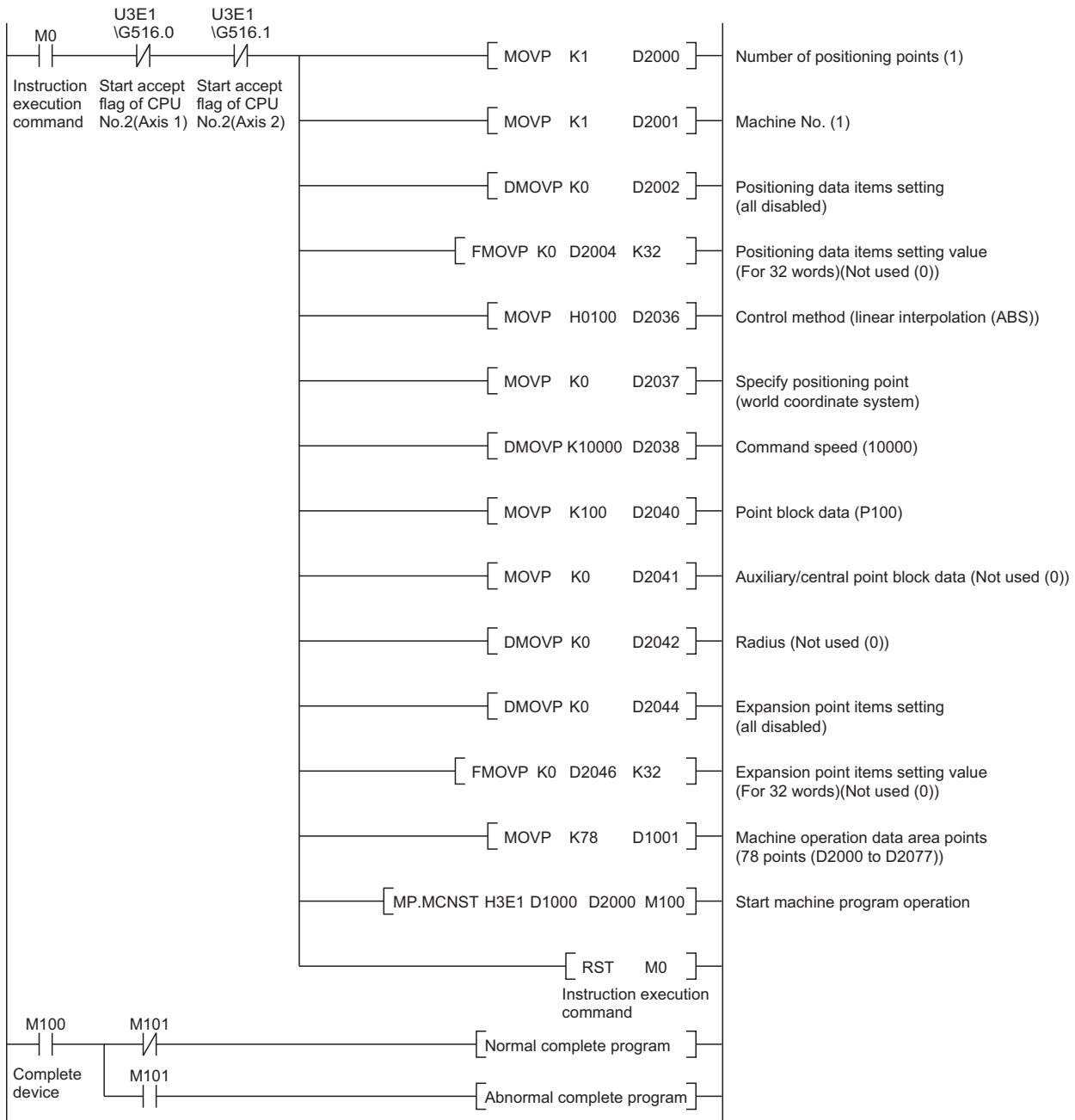

Write bit device to the Motion CPU: M(P).BITWR/D(P).BITWR

Instruction	Condition	Sequence program*1
MP.BITWR DP.BITWR		Command Command
M.BITWR D.BITWR		Command Command

*1 □: Instruction (M(P).BITWR: M, D(P).BITWR: D)

Setting data

Usable devices

○: Usable, △: Usable partly

Setting data*3	Usable devices											
	Internal devices (System, User)		File register		Link direct device J□\□		Module access device U□\G□		Index register Z□	Constant		Others
	Bit	Word	Bit	Word	Bit	Word	Bit	Word		Decimal K, Hexadecimal H	Real character string	
(n1)		○		○						○		
(D1)		○		○							○	
(n2)		○		○						○		
(D2)*1	△*2		△*2									
(D3)*1		△*2		△*2								

*1 Omission possible with both of (D2) and (D3) omission.

*2 Local devices cannot be used.

*3 Setting data (n1) to (D3): Index qualification possible (except constant)

Description, range, setting side, data type

Setting data	Description	Setting range	Set by	Data type
(n1)	(First I/O No. of the target CPU)/16 Value to specify actually is the following.*2 CPU No.2: 3E1H, CPU No.3: 3E2H, CPU No.4: 3E3H	3E1H to 3E3H	User	16-bit binary
(D1)	Bit device of the target Motion CPU that conducts the bit operation (includes word device bit specification)	—	User	Character string
(n2)	Bit operation Value to specify actually is the following. OFF: 0 ON: 1	0 to 1	User	16-bit binary
(D2)*1	Complete devices • (D2+0): Device which make turn on for one scan at accept completion of instruction. • (D2+1): Device which make turn on for one scan at accept abnormal completion of instruction. ("D2+0" also turns on at the abnormal completion.)	—	System	Bit
(D3)*1	Complete status storage device	—	System	Word

*1 Omission possible with both of (D2) and (D3) omission.

*2 Motion CPU cannot be set as CPU No.1 in the Multiple CPU configuration.

Processing details

■Controls

- For a Multiple CPU system configuration, the bit device specified with (D1) of the target CPU (n1) turns ON or OFF with the bit operation of (n2).

Point

If reading a bit device of the target CPU, use the M(P).DDR/D(P).DDR instructions. Refer to the following for details on the M(P).DDR/D(P).DDR instructions.

📖 MELSEC iQ-R Programming Manual (Instructions, Standard Functions/Function Blocks)

■Operation

Outline operation between CPUs at the MP.BITWR and DP.BITWR instruction execution is shown below.

- MP.BITWR instruction

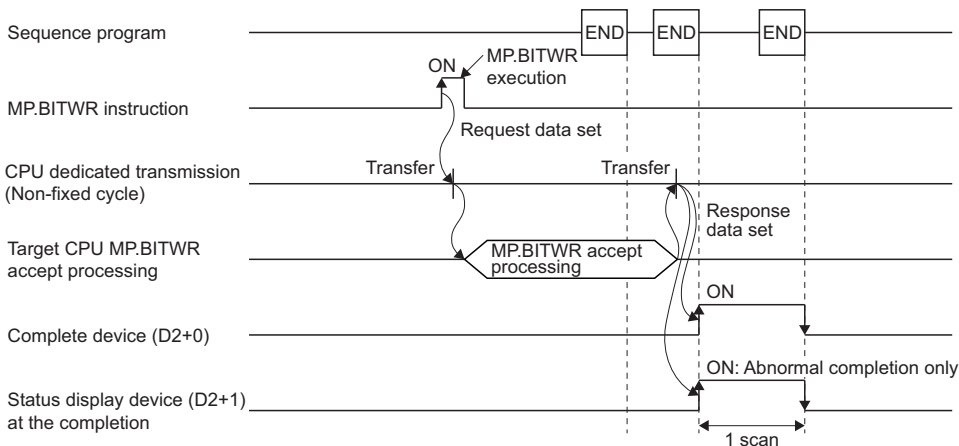

- DP.BITWR instruction

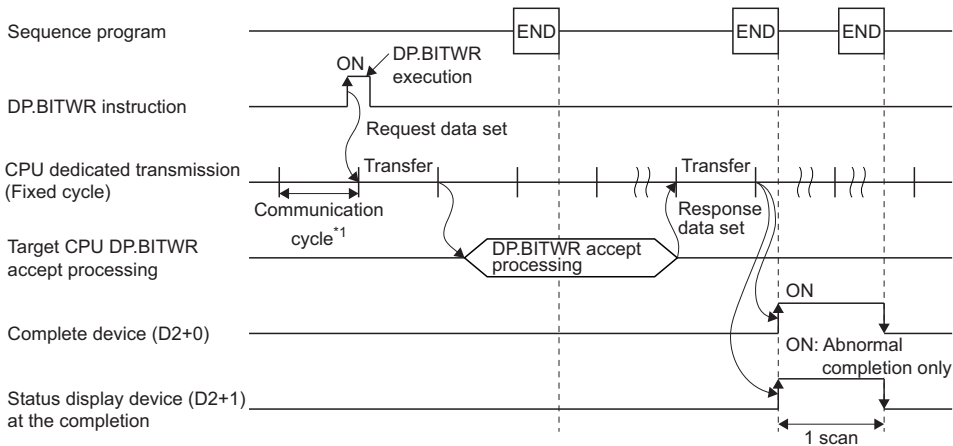

*1 Set in [System Parameter] ⇒ [Multiple CPU settings] in GX Works3

Operation error

- The abnormal completion in the case shown below, and the error code is stored in the device specified with the complete status storage device (D3). If the complete status storage device (D3) is omitted, an error is not detected and operation becomes "No operation".

Complete status*1 (Error code) (H)	Error factor	Corrective action
0010	Instruction request to Motion CPU from PLC CPU exceeds the permissible value.	Check the sequence program, and correct it.
2230	Character string data (D1) is wrong in M(P).BITWR/D(P).BITWR instructions.	
2231	The bit operation set in the M(P).BITWR/D(P).BITWR instruction is outside the range of 0 to 1.	

*1 0000H (Normal)

- An operation error occurs, "Latest self-diagnosis error detection (SM0)" is turned on, and an error code is stored in "Latest self-diagnosis error (SD0)" in the cases shown below.

Error code (H)*1	Error factor	Corrective action
2800	The start I/O number (the first 3 digits when expressed in 4-digit hexadecimal) of the specified other CPU module is outside the range of 3E0H to 3E3H.	Check the sequence program, and correct it.
2801	The specified other CPU module is wrong. <ul style="list-style-type: none"> The reserved CPU is specified. The uninstalled CPU is specified. 	
2802	The other CPU module does not support M(P).BITWR/D(P).BITWR instructions.	

*1 0000H (Normal)

Program example

■ Program which turns ON M2042 of the Motion CPU (CPU No.2), when M0 turned ON

- (Example 1) Program which omits the complete device and complete status.

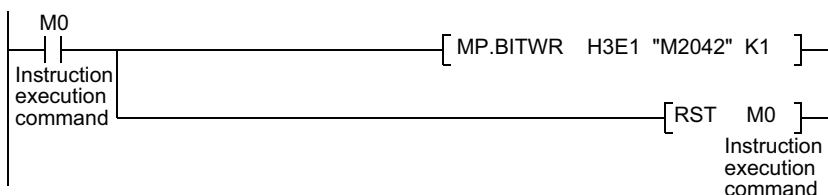

- (Example 2) Program which uses the complete device and complete status.

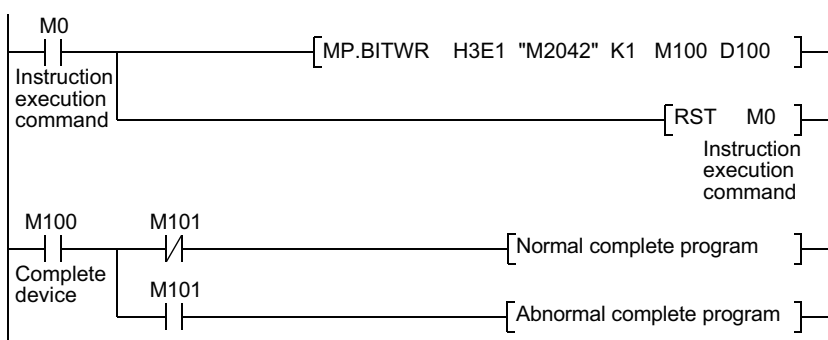

Interrupt instruction to the other CPU: M(P).GINT/D(P).GINT

Instruction	Condition	Sequence program*1
MP.GINT DP.GINT		Command Command
M.GINT D.GINT		Command Command

*1 □: Instruction (M(P).GINT: M, D(P).GINT: D)

Setting data

Usable devices

○: Usable, △: Usable partly

Setting data*3	Usable devices											
	Internal devices (System, User)		File register		Link direct device J□\□		Module access device U□\G□		Index register Z□	Constant		Others
	Bit	Word	Bit	Word	Bit	Word	Bit	Word		Decimal K, Hexadecimal H	Real character string	
(n1)		○		○							○	
(n2)		○		○							○	
(D1)*1	△*2			△*2								
(D2)*1		△*2		△*2								

*1 Omission possible with both of (D1) and (D2) omission.

*2 Local devices cannot be used.

*3 Setting data (n1) to (D2): Index qualification possible (except constant)

Description, range, setting side, data type

Setting data	Description	Setting range	Set by	Data type
(n1)	(First I/O No. of the target CPU)/16 Value to specify actually is the following.*2 CPU No.2: 3E1H, CPU No.3: 3E2H, CPU No.4: 3E3H	3E1H to 3E3H	User	16-bit binary
(n2)	Interrupt instruction No.	0 to 15	User	16-bit binary
(D1)*1	Complete devices • (D1+0): Device which make turn on for one scan at accept completion of instruction. • (D1+1): Device which make turn on for one scan at accept abnormal completion of instruction. ("D1+0" also turns on at the abnormal completion.)	—	System	Bit
(D2)*1	Complete status storage device	—	System	Word

*1 Omission possible with both of (D1) and (D2) omission.

*2 Motion CPU cannot be set as CPU No.1 in the Multiple CPU configuration.

Processing details

Controls

- Generate a "PLC interrupt event task" for the number specified by (n2) of the PLC CPU, to the Motion CPU specified by (n1).
- Event processing is not executed when the Motion CPU side is DI (interrupt disable). Execute the EI (interrupt enable) instruction before event processing.

■ Operation

Outline operation between CPUs at the MP.GINT and DP.GINT instruction execution is shown below.

• MP.GINT instruction

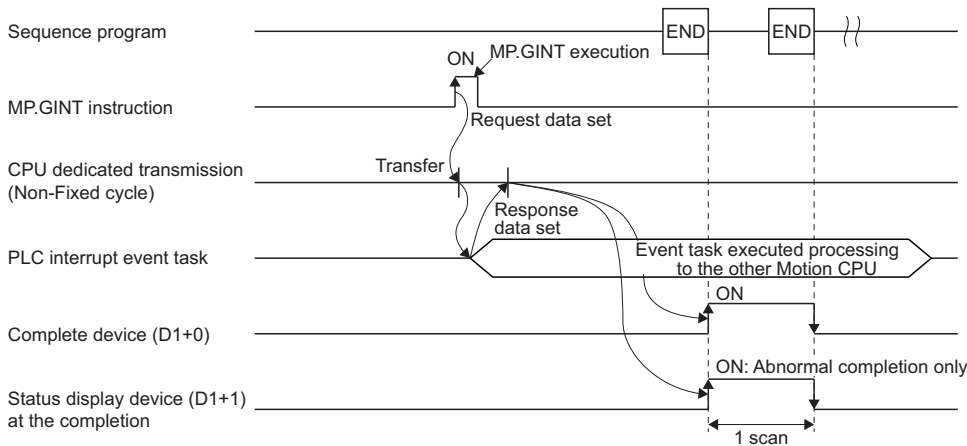

• DP.GINT instruction

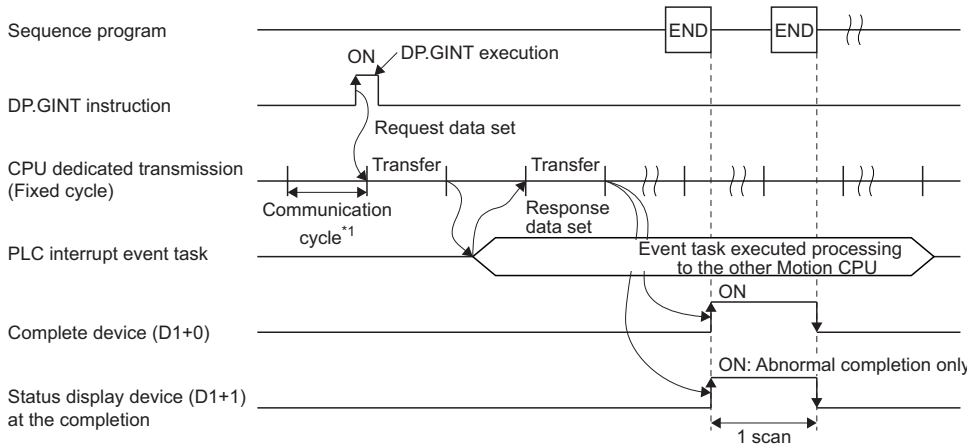

*1 Set in [System Parameter] ⇒ [Multiple CPU settings] in GX Works3

Operation error

- The abnormal completion in the case shown below, and the error code is stored in the device specified with the complete status storage device (D2). If the complete status storage device (D2) is omitted, an error is not detected and operation becomes "No operation".

Complete status*1 (Error code) (H)	Error factor	Corrective action
0010	Instruction request to Motion CPU from PLC CPU exceeds the permissible value.	Check the sequence program, and correct it.
2282	The interrupt pointer No. set in the M(P).GINT/D(P).GINT instruction is outside the range of 0 to 15.	

*1 0000H (Normal)

- An operation error occurs, "Latest self-diagnosis error detection (SM0)" is turned on, and an error code is stored in "Latest self-diagnosis error (SD0)" in the cases shown below.

Error code (H)*1	Error factor	Corrective action
2800	The start I/O number (the first 3 digits when expressed in 4-digit hexadecimal) of the specified other CPU module is outside the range of 3E0H to 3E3H.	Check the sequence program, and correct it.
2801	The specified other CPU module is wrong. <ul style="list-style-type: none"> The reserved CPU is specified. The uninstalled CPU is specified. 	

*1 0000H (Normal)

Program example

■ Program which generates interrupt of interrupt pointer number 10 toward the Motion CPU (CPU No.2), when M0 turned ON

- (Example 1) Program which omits the complete device and complete status.

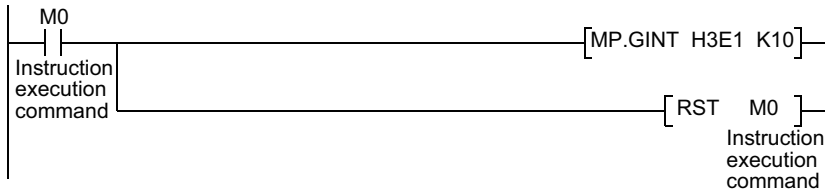

- (Example 2) Program which uses the complete device and complete status.

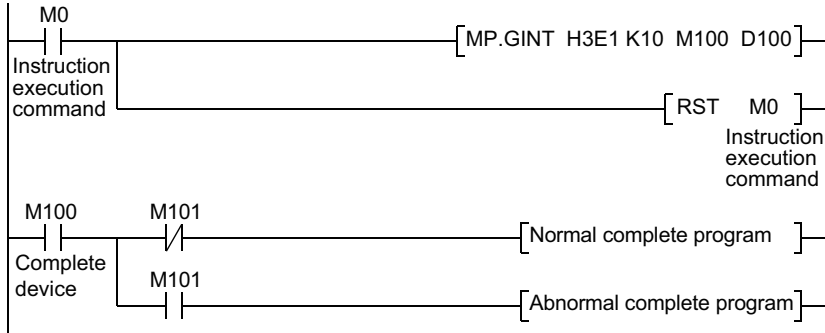

2.3 Precautions

CPU buffer memory address used in Motion dedicated instruction

Information corresponding to positioning dedicated signal is output to the system area on the CPU buffer memory (U3E□\G0 to 2k points) of the Motion CPU. When executing Motion dedicated PLC instructions, interlock the signals of this area.

2

Start accept flag (System area)

The status of each flag is stored in the following address.

CPU buffer memory address () is decimal address	Description																														
204H(516) 205H(517) 206H(518) 207H(519)	<p>The start accept flag for 64 axes are stored corresponding to each bit. Bits are actually set as the following:</p> <ul style="list-style-type: none"> • R64MTCPU: J1 to J64 • R32MTCPU: J1 to J32 • R16MTCPU: J1 to J16 <p>OFF: Start accept enable ON: Start accept disable</p> <table border="1"> <thead> <tr> <th></th> <th>b15</th> <th></th> <th>b2</th> <th>b1</th> <th>b0</th> </tr> </thead> <tbody> <tr> <td>204H(516) address</td> <td>J16</td> <td>••••••••</td> <td>J2</td> <td>J1</td> <td></td> </tr> <tr> <td>205H(517) address</td> <td>J32</td> <td>••••••••</td> <td>J18</td> <td>J17</td> <td></td> </tr> <tr> <td>206H(518) address</td> <td>J48</td> <td>••••••••</td> <td>J34</td> <td>J33</td> <td></td> </tr> <tr> <td>207H(519) address</td> <td>J64</td> <td>••••••••</td> <td>J50</td> <td>J49</td> <td></td> </tr> </tbody> </table>		b15		b2	b1	b0	204H(516) address	J16	••••••••	J2	J1		205H(517) address	J32	••••••••	J18	J17		206H(518) address	J48	••••••••	J34	J33		207H(519) address	J64	••••••••	J50	J49	
	b15		b2	b1	b0																										
204H(516) address	J16	••••••••	J2	J1																											
205H(517) address	J32	••••••••	J18	J17																											
206H(518) address	J48	••••••••	J34	J33																											
207H(519) address	J64	••••••••	J50	J49																											
20EH(526) 20FH(527) 210H(528) 211H(529)	<p>The command generation axis start accept flag for 64 axes are stored corresponding to each bit. Bits are actually set as the following:</p> <ul style="list-style-type: none"> • R64MTCPU: J1 to J64 • R32MTCPU: J1 to J32 • R16MTCPU: J1 to J16 <p>OFF: Start accept enable ON: Start accept disable</p> <table border="1"> <thead> <tr> <th></th> <th>b15</th> <th></th> <th>b2</th> <th>b1</th> <th>b0</th> </tr> </thead> <tbody> <tr> <td>20EH(526) address</td> <td>J16</td> <td>••••••••</td> <td>J2</td> <td>J1</td> <td></td> </tr> <tr> <td>20FH(527) address</td> <td>J32</td> <td>••••~•••</td> <td>J18</td> <td>J17</td> <td></td> </tr> <tr> <td>210H(528) address</td> <td>J48</td> <td>••••~•••</td> <td>J34</td> <td>J33</td> <td></td> </tr> <tr> <td>211H(529) address</td> <td>J64</td> <td>••••~•••</td> <td>J50</td> <td>J49</td> <td></td> </tr> </tbody> </table>		b15		b2	b1	b0	20EH(526) address	J16	••••••••	J2	J1		20FH(527) address	J32	••••~•••	J18	J17		210H(528) address	J48	••••~•••	J34	J33		211H(529) address	J64	••••~•••	J50	J49	
	b15		b2	b1	b0																										
20EH(526) address	J16	••••••••	J2	J1																											
20FH(527) address	J32	••••~•••	J18	J17																											
210H(528) address	J48	••••~•••	J34	J33																											
211H(529) address	J64	••••~•••	J50	J49																											

The start accept flag is set after instruction acceptance of by the Motion CPU as follows.

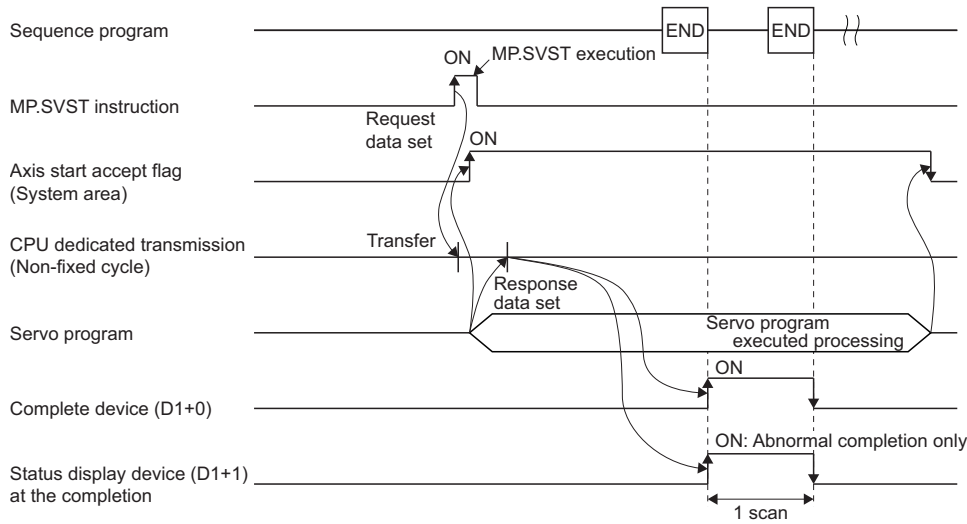

The start accept flag does not turn ON until the instruction accepting of instruction is completed by the Motion CPU after instruction execution by the PLC CPU. Therefore, use a user device created interlock as required to prevent the execution of the next Motion dedicated PLC instruction and avoid a same axis double start error.

Program example

- Program which executes continuous start of servo program No. 11 for Axis 1 of the Motion CPU (CPU No.2), while X0 is ON.

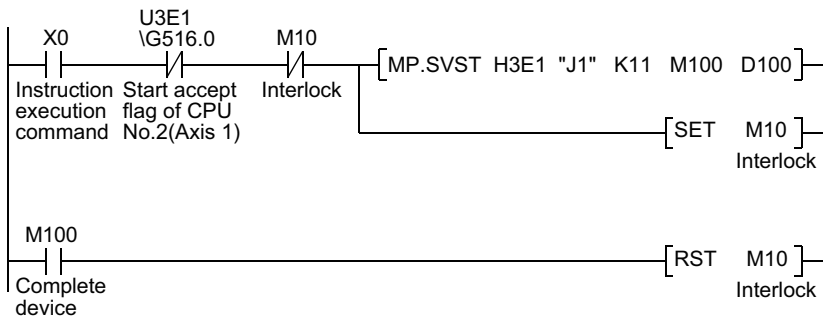

Number of blocks used for Motion dedicated PLC instruction

Number of blocks for Multiple CPU dedicated instruction transmission area

■Number of CPU dedicated instruction transmission area

The Multiple CPU dedicated instruction transmission area used by Motion dedicated PLC instructions is managed in blocks with a minimum unit of 16 words. The number of blocks used by each CPU is shown in the table below.

Number of Multiple CPU modules	Number of CPU dedicated instruction transmission area for each target CPU
2	599 blocks
3	299 blocks
4	199 blocks

■Number of blocks used for Motion dedicated PLC instruction

Each Motion dedicated PLC instruction uses a certain number of blocks in the CPU dedicated instruction transmission area until the "complete device" turns on by the PLC CPU after instruction execution. The number of blocks used by Motion dedicated PLC instructions is shown in the table below.

Instructions	Number of blocks used
M(P).SFCS/D(P).SFCS	1
M(P).SVST/D(P).SVST	$1 + \lceil (1 + \lceil j / 2 \rceil) / 16 \rceil^{-1}$
M(P).SVSTD/D(P).SVSTD	$1 + \lceil (n + \lceil m / 2 \rceil + 1) / 16 \rceil^{-1}$
M(P).CHGA/D(P).CHGA	2
M(P).CHGAS/D(P).CHGAS	2
M(P).CHGV/D(P).CHGV	2
M(P).CHGVS/D(P).CHGVS	2
M(P).CHGT/D(P).CHGT	2
M(P).MCNST/D(P).MCNST	$1 + \lceil n / 16 \rceil^{-1}$
M(P).DDWR/D(P).DDWR	3^{*2}
M(P).DDR/D(P).DDR	2^{*3}
M(P).BITWR/D(P).BITWR	$1 + \lceil (1 + \lceil j / 2 \rceil) / 16 \rceil^{-1}$
M(P).GINT/D(P).GINT	1

*1 Calculated by the calculation expression

j=Number of characters of the Axis No. specified by (S1)

n=Number of positioning data points specified by (S1+1)

m=Number of characters of the character string data specified by (D1)

inside $\lceil \rceil$ =Round up after the decimal

*2 When the number of writing data is 11 words or less, number of blocks used is 2.

*3 When the number of reading data is 13 words or less, number of blocks used is 2.

■Operation example

Below is an example when 12 M(P).SVST instructions (8 characters) and 12 M(P).DDWR instructions (number of writing data: 12 words) are executed simultaneously.

The number of blocks used is as follows;

12 M(P).SVST instructions issued \times 2 blocks each used + 12 M(P).DDWR instructions issued \times 2 blocks each used
= 48 (Total blocks used)

Number of simultaneous issues for Multiple CPU dedicated instructions

When the number of blocks being used to communicate with each CPU in the Multiple CPU dedicated instruction transmission area exceeds the set value for "maximum number of blocks used for the Multiple CPU dedicated instruction setting" in the Multiple CPU setting (special registers SD796 to SD799 of PLC CPU), the system enters a state where the Motion dedicated PLC instruction is not accepted (permissible number of executions exceeded state). At the time of Motion dedicated instruction execution towards the target CPU, an abnormal complete status "0010H" is set in the complete status device. If the complete device is omitted, no operation occurs at all.

An interlock can be created using special relays containing block-use information (SM796 to SM799 of the PLC CPU) so that the permissible number of executions is not exceeded.

- Special relay of PLC CPU

Device No.	Name	Meaning	Explanation	Set by
SM796	Block information using Multiple CPU dedicated instruction (For CPU No.1)	OFF: Block is secured ON: Block set by SD796 cannot be secured	Turns ON when the number of the remaining blocks of the dedicated instruction transmission area used for the Multiple CPU dedicated instruction is less than the number of blocks specified by "SD796 to SD799". Turns ON at instruction execution. Turns OFF when empty area exists at END processing.	System (When instruction/END processing executed)
SM797	Block information using Multiple CPU dedicated instruction (For CPU No.2)	OFF: Block is secured ON: Block set by SD797 cannot be secured		
SM798	Block information using Multiple CPU dedicated instruction (For CPU No.3)	OFF: Block is secured ON: Block set by SD798 cannot be secured		
SM799	Block information using Multiple CPU dedicated instruction (For CPU No.4)	OFF: Block is secured ON: Block set by SD799 cannot be secured		

- Special register of PLC CPU

Device No.	Name	Meaning	Explanation	Set by
SD796	Maximum number of blocks used for the Multiple CPU dedicated instruction setting (For CPU No.1)	Maximum number of blocks range for dedicated instructions depends on the number of CPUs in the Multiple CPU system configuration.*1 2 CPU configuration: 2 to 599 3 CPU configuration: 2 to 299 4 CPU configuration: 2 to 199 (Default: 2)	Specifies the maximum number of blocks used for the Multiple CPU dedicated instruction. When the dedicated instruction of Multiple CPU is executed to the target CPU, and the number of empty blocks of the dedicated instruction transmission area is less than the setting value of this register, "SM796 to SM799" is turned ON, which is used as the interlock signal for consecutive execution of the dedicated instruction of Multiple CPU.	User (At 1 scan after RUN)
SD797	Maximum number of blocks used for the Multiple CPU dedicated instruction setting (For CPU No.2)			
SD798	Maximum number of blocks used for the Multiple CPU dedicated instruction setting (For CPU No.3)			
SD799	Maximum number of blocks used for the Multiple CPU dedicated instruction setting (For CPU No.4)			

*1 When setting a value outside the range, the register operates as the maximum value for the range of the Multiple CPU system configuration.

Point

When

Maximum number of blocks used for the Multiple CPU dedicated instruction setting (SD796 to 799) ≤ Number of empty blocks of the dedicated instruction transmission area < number of blocks used by the instruction

at the execution of a Motion dedicated PLC instruction, the instruction is not executed (it is a no operation state) in the current scan, but executed in the next scan.

When inserting an interlock condition by "Block information using Multiple CPU dedicated instruction (SM796 to SM799)", set a value equal to or more than the number of blocks used by the instructions executed in "Maximum number of blocks used for the Multiple CPU dedicated instruction setting (SD796 to SD799)"

■ Operation timing

Operation which executes each Motion dedicated instruction and turns on the Multiple CPU block information.

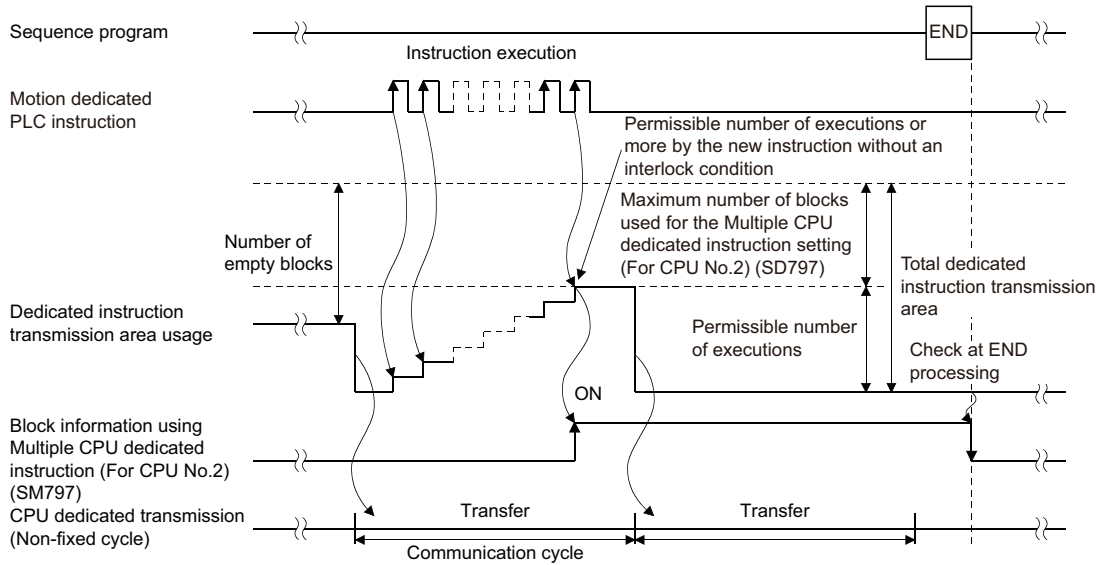

■ Operation example

When multiple D(P).DDWR instructions (80 words) are executed simultaneously before turning on each complete device in the 4 Multiple CPUs.

If the number of blocks used for each item is set as follows,

- Number of CPU dedicated instruction transmission area: 199 blocks (Initial value)
- Maximum number of blocks used for the Multiple CPU dedicated instruction setting (For CPU No.2) (SD797): 2 (Initial value)
- D(P).DDWR number of blocks used: 6

And, when 33 D(P).DDWR instructions are issued within the Multiple CPU fixed cycle transmission cycle (0.888ms), the number of blocks used is as follows.

$$6 \text{ (D(P).DDWR number of blocks)} \times 33 \text{ (D(P).DDWR instructions)} = 198 \text{ (Total blocks used)}$$

Therefore, the number of empty blocks is as follows;

$$199 \text{ (Number of CPU dedicated instruction transmission area)} - 198 \text{ (Total blocks used)} = 1 \text{ (Number of empty blocks)}$$

$$1 \text{ (Number of empty blocks)} < 2 \text{ (Maximum number of blocks used for the Multiple CPU dedicated instruction setting (For CPU No. 2) (SD797))}$$

In the above case, the number of empty blocks is less than the "Maximum number of blocks used for the Multiple CPU dedicated instruction setting (For CPU No. 2) (SD797)", therefore "Block information using Multiple CPU dedicated instruction (For CPU No. 2) (SM797)" turns on.

If a new instruction is executed while in this status, it will be more than the permissible number of executions. However, this can be avoided by using "Block information using Multiple CPU dedicated instruction (For CPU No. 2) (SM797)" as an interlock.

■ Program example

- Program which sets 2 (Initial value) to SD797 and uses SM797 as an interlock when DP.DDWR (Number of blocks used: 2) is executed.

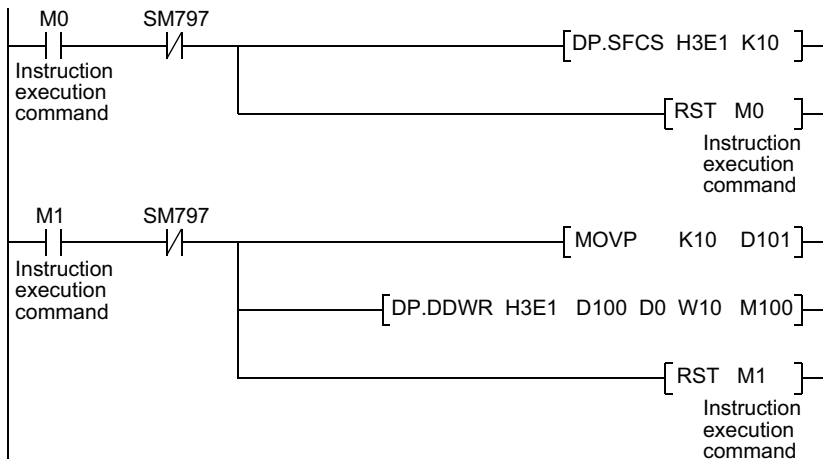

- Program which sets 1 to SD797 and uses SM797 as an interlock condition when D(P).DDWR/D(P).DDR D is not executed.

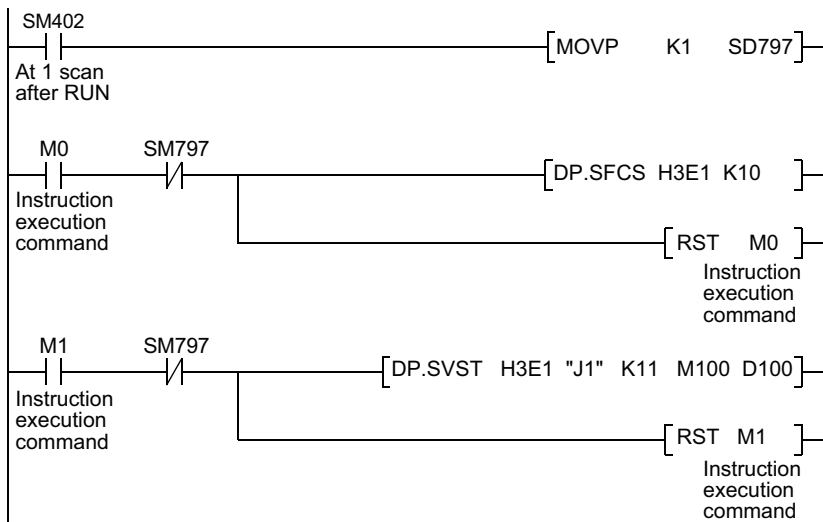

Number of simultaneous acceptances for Multiple CPU dedicated instructions

The number of instructions that can be accepted simultaneously in the Motion CPU is shown in the table below.

Instruction	Number of simultaneous acceptances
M(P).SFCS/D(P).SFCS	64
M(P).SVST/D(P).SVST	256 instructions total
M(P).SVSTD/D(P).SVSTD	
M(P).CHGA/D(P).CHGA	
M(P).CHGAS/D(P).CHGAS	
M(P).MCNST/D(P).MCNST	
M(P).CHGV/D(P).CHGV	No limitation*1 (The command speed and torque limit value of the instructions last executed is valid)
M(P).CHGVS/D(P).CHGVS	
M(P).CHGT/D(P).CHGT	
M(P).DDWR/D(P).DDWR	No limitation*1 (Processed in the order of issue)
M(P).DDRD/D(P).DDRD	
M(P).BITWR/D(P).BITWR	
M(P).GINT/D(P).GINT	

*1 The number of simultaneous executions is dependent on the number of CPU dedicated instruction empty blocks on the PLC CPU side.

When more than the above number of instructions are executed by the PLC CPU, even if there is enough area in the CPU dedicated instruction transmission area, the Motion CPU cannot accept it. In this case, 2100H is set to the complete status information and abnormal completion occurs.

Execution of Motion dedicated PLC instruction

- Motion dedicated PLC instruction can be executed with a fixed cycle execute type program and interrupt program. However, the complete device is a pulse-type. If the complete device (M100 in below example) is set, it may not be recognized during the PLC scan. Therefore, the sequence program should scan for completion of the device and use a set bit to execute the Motion instruction string.

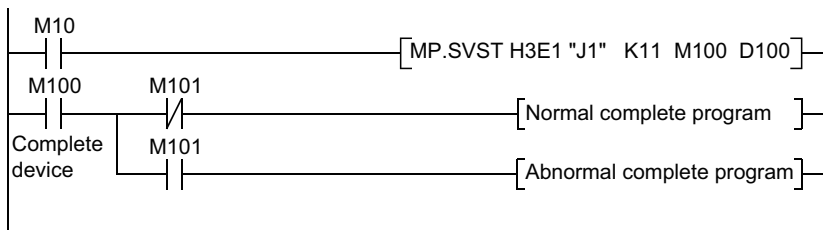

- The below devices cannot be used as program file registers or local devices.
 - Each instruction's complete device and complete status
 - M(P).DDRD/D(P).DDRD instruction of D1 (First device of the self CPU where the reading data is stored.)
- When using the Motion dedicated function of the operation control step (Fn/FSn) and servo program (Kn) in Motion CPU, it is necessary to create a user-defined interlock using WAIT transition (Gn) as shown below.

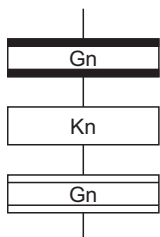

Complete status information

The codes stored in complete status at the completion of Motion dedicated PLC instruction are shown below. If the complete status storage device is omitted, an error is not detected and operation becomes "No operation".

Complete status (Error code) (H)	Error factor
0	Normal completion
0010	Instruction request to Motion CPU from PLC CPU exceeds the permissible value.*2
1001*1	The specified device cannot be used in the CPU, or it is outside the device range.
1080*1	Number of writing data points set by M(P).DDWR/D(P).DDWR instruction is wrong.
1081*1	Number of reading data points set by M(P).DDWR/D(P).DDR instruction is wrong.
2000*1	Command that cannot be decoded in the Motion CPU was specified.
2100*1	<p>■M(P).SFCS/D(P).SFCS instruction use There are 65 or more simultaneous M(P).SFCS/D(P).SFCS instruction requests to the Motion CPU from the PLC CPU, therefore the Motion CPU cannot process them.</p> <p>■M(P).SVST/D(P).SVST/M(P).SVSTD/D(P).SVSTD/M(P).CHGA/D(P).CHGA/M(P).CHGAS/D(P).CHGAS/M(P).MCNST/D(P).MCNST instruction use There are 257 or more simultaneous M(P).SVST/D(P).SVST/M(P).SVSTD/D(P).SVSTD/M(P).CHGA/D(P).CHGA/M(P).CHGAS/D(P).CHGAS/M(P).MCNST/D(P).MCNST instruction requests to the Motion CPU from the PLC CPU, therefore the Motion CPU cannot process them.</p>
2200*1	The starting Motion SFC program No. is outside the range of 0 to 511 (for operating system software version "09" or earlier, 0 to 255).
2201*1	The servo program No. to execute is outside the range of 0 to 8191 (for operating system software version "09" or earlier, 0 to 4095).
2202*1	Axis No. set by M(P).SVST/D(P).SVST instruction is wrong.
2203*1	Axis No. set by M(P).CHGA/D(P).CHGA instruction is wrong.
2204*1	Axis No. set by M(P).CHGV/D(P).CHGV instruction is wrong.
2205*1	Axis No. set by M(P).CHGT/D(P).CHGT instruction is wrong.
2207*1	Axis No. set by M(P).CHGAS/D(P).CHGAS instruction is wrong.
2208*1	Axis No. set by M(P).CHGVS/D(P).CHGVS instruction is wrong.
2209*1	Axis No. set by M(P).SVSTD/D(P).SVSTD instruction is wrong.
2220*1	Instruction area for M(P).SVSTD/D(P).SVSTD instructions is not enough. (There are 128 or more instructions in operation by M(P).SVSTD/D(P).SVSTD instructions)
2221*1	The positioning data area points for M(P).SVSTD/D(P).SVSTD instruction is wrong.
2222*1	Instructions for M(P).SVSTD/D(P).SVSTD instructions are only NOP or resting axes.
2224*1	Positioning data items that must be set in instructions by M(P).SVSTD/D(P).SVSTD instructions have not been set.
2225*1	Character string data (D1) is wrong in M(P).SVSTD/D(P).SVSTD instructions.
2230*1	Character string data (D1) is wrong in M(P).BITWR/D(P).BITWR instructions.
2231*1	The bit operation set in the M(P).BITWR/D(P).BITWR instruction is outside the range of 0 to 1.
2240*1	Instruction area for M(P).MCNST/D(P).MCNST instructions is not enough. (There are 9 or more instructions in operation by the Motion dedicated PLC instructions (M(P).MCNST/D(P).MCNST) and Motion dedicated function (MCNST))
2241*1	The machine positioning data area setting for M(P).MCNST/D(P).MCNST instruction is wrong.
2242*1	The control method for each point of the M(P).MCNST/D(P).MCNST instruction is wrong. (Includes when the control method for every point is NOP only)
2243*1	Machine No. set by M(P).MCNST/D(P).MCNST instruction is wrong.
2282*1	The interrupt pointer No. set in the M(P).GINT/D(P).GINT instruction is outside the range of 0 to 15.

*1 The error code is dedicated with the Motion CPU.

*2 Permissible value is different depending on the number of CPU modules.

Order of instruction execution

Methods to control using execution data after it is transmitted from the PLC CPU to the Motion CPU are shown below.

Method to execute after data is written to the CPU buffer memory

Write the data from PLC CPU to the buffer memory (Fixed cycle transmission area) of the self CPU, and then it can be utilized for Motion dedicated PLC instruction execution.

Program example

Program which starts the servo program (positioning) by DP.SVST instruction after the data has been writing to CPU buffer memory (Fixed cycle transmission area (U3E0\HG0 to U3E0\HG3) from PLC CPU (CPU No.1).

Sequence program (PLC CPU side)

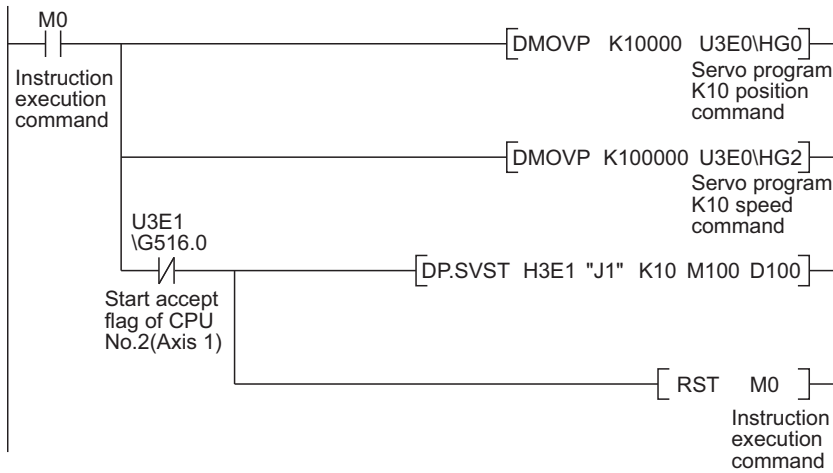

Servo program (Motion CPU side)

[K 10: Real]
1 INC-1
Axis 1, U3E0\GH0 μm
Speed U3E0\HG2 mm/min

Method to execute after data is written by M(P).DDWR/D(P).DDWR instruction

Write the data from the PLC CPU to the Motion CPU by M(P).DDWR/D(P).DDWR instruction, and then it can be utilized for Motion dedicated PLC instruction execution.

Program example

Program which starts the servo program (positioning) by MP.SVST instruction after data is written to D3000 to D3002 of the Motion CPU (CPU No.2) from the PLC CPU (CPU No.1) by MP.DDWR.

Sequence program (PLC CPU side)

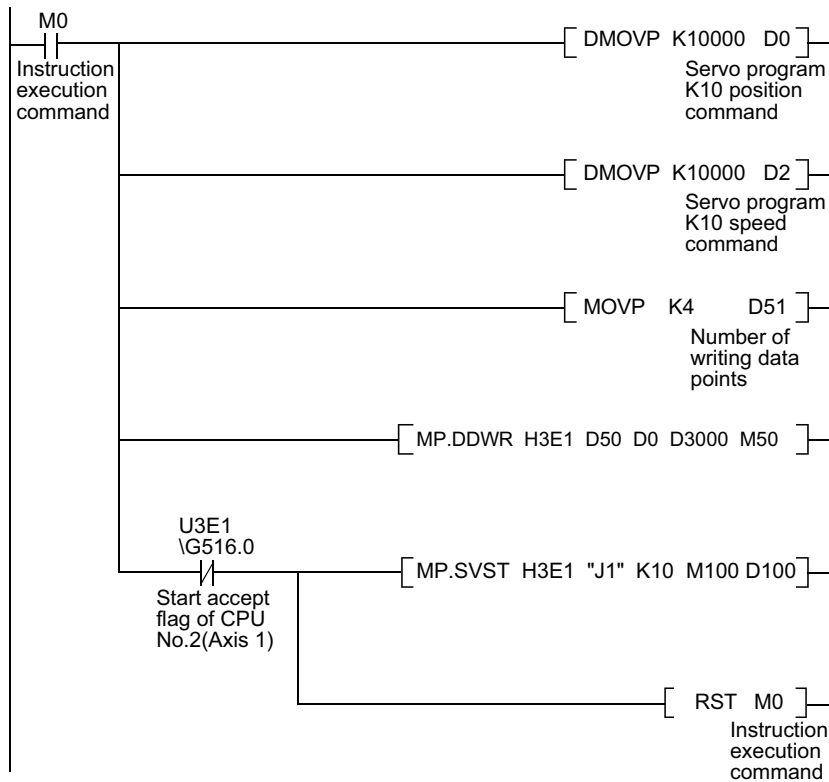

Servo program (Motion CPU side)

[K 10: Real]
1 INC-1
Axis 1, D3000 μm
Speed D3002 mm/min

3 MOTION SFC PROGRAMS

3.1 Motion SFC Program Configuration

The Motion SFC Program is constituted by the combination of start, steps, transitions, end and others are shows below.

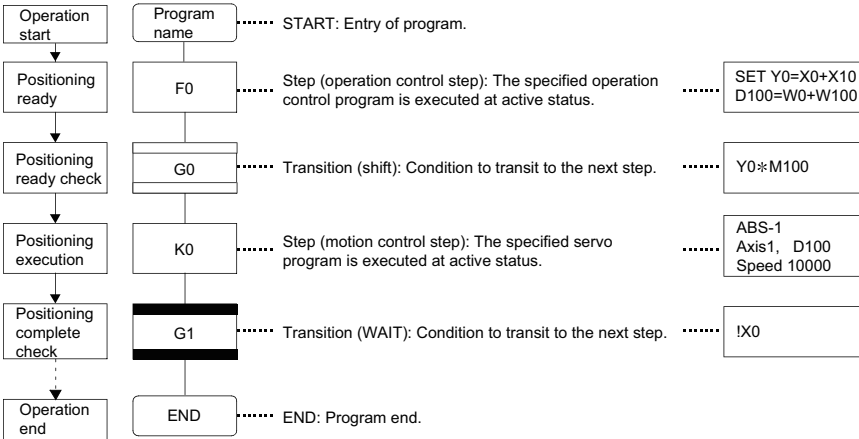

The above Motion SFC program to be started performs the following operations.

1. The step (F0) is activated and the operation specified with the step (F0) is executed (positioning ready). A step in such an active state is called an active step.
2. Whether the condition specified with the transition (G0) has enabled or not (whether the positioning program can be started or not) is checked. The active step (F0) is deactivated at the completion of condition and the next step (K0) is activated. (Servo program (K0) is started)
3. The operating completion of the step (K0) (positioning completion of the servo program K0) is checked, and control transits to the next step at operating completion (completion of condition).
4. With the transition of the active step as described in above 1. to 3., control is executed and ends at END.

Refer to the task operation for details of the execution timing of the Motion SFC program such as above. (☞ Page 286 Task operation)



Point



The combined number of steps for all Motion SFC programs which can be active simultaneously is up to 1024 (for operating system software version "08" or earlier, up to 256). Exceeding 1024 steps will result in the minor error(SFC) (error code: 33FEH). Each symbol of the Motion SFC program is as follows.

F/FS: Operation control, K: Positioning control, G: Judgment

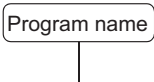
3.2 Motion SFC Chart Symbol List

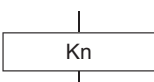
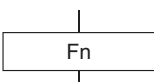
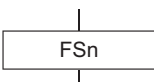
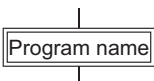
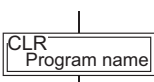
Parts as Motion SFC program components are shown below. The operation sequence or transition control is expressed with connecting these parts by directed lines in the Motion SFC program.

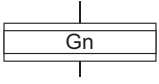
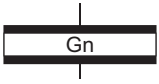
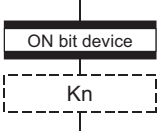
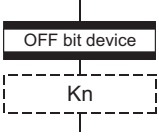
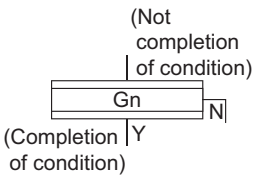
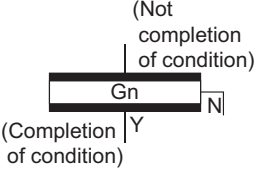
Classification	Name	Symbol (Code size (byte))	Function
Program start/ end	START	 (0)	<ul style="list-style-type: none"> Indicates an entry of program as a program name. Specify this program name at a subroutine call. Only one program name for one program.
	END	 (8)	<ul style="list-style-type: none"> Indicates an end (exit) of program. When a subroutine call was carried out, returns to the call source program. Multiple program names or no symbols for one program.
Step	Motion control step	 (8)	Starts a servo program Kn (K0 to K8191) ^{*1} .
	Once execution type operation control step	 (8)	Execute once the operation control program Fn (F0 to F4095).
	Scan execution type operation control step	 (8)	Repeats an operation control program FSn (FS0 to FS4095) until the next transition condition enables.
	Subroutine call/start step	 (8)	<ul style="list-style-type: none"> When the next of GSUB is WAIT, performs "subroutine call" and transits control to the specified program. Control returns to the call source program at END execution. When the next of GSUB is except WAIT, performs "subroutine start", and starts the specified program and transits to the next (lower part). The start source and destination programs are executed simultaneously, and the call destination program ends at END execution.
	Clear step	 (8)	<ul style="list-style-type: none"> Stops and ends the specified program running. After an end, it is started from the initial (start step) by restarting the program. When the specified program is during "subroutine call", the subroutine program is also stopped to execute. When the specified program is after "subroutine start", the subroutine program is not stopped to execute. When clearing to the subroutine by which the "subroutine call" was executed, the specified subroutine is stopped to execute, returns to the call source program, and transits to the next.

Classification	Name	Symbol (Code size (byte))	Function
Transition	Shift (Pre-read transition)	 (8)	<ul style="list-style-type: none"> When just before is the motion control step, transits to the next step by formation of transition condition Gn (G0 to G4095) without waiting for the motion operating completion. When just before is the operation control step, transits to the next step by the completion of transition condition after operating execution. When just before is subroutine call or starting step, transits to the next step by formation of transition condition without waiting for the operating completion of subroutine.
	WAIT	 (8)	<ul style="list-style-type: none"> When just before is the motion control step, waits for the motion operating completion and then transits to the next step by the completion of transition condition Gn (G0 to G4095). When just before is the operation control step, transits to the next step by formation of transition condition after operating execution. (Same operation as Shift.) When just before is subroutine call or starting step, waits for the operating completion of subroutine and then transits to the next step by the completion of transition condition.
	WAITON	 (14)	<ul style="list-style-type: none"> Prepares for starting of the next motion control step, and issues an instruction immediately when the specified bit device turns ON. Always pair this transition with the motion control step one-for-one.
	WAITOFF	 (14)	<ul style="list-style-type: none"> Prepares for starting of the next motion control step, and issues an instruction immediately when the specified bit device turns OFF. Always pair this transition with the motion control step one-for-one.
	Shift Y/N	 (8)	<ul style="list-style-type: none"> When just before is the motion control step, transits to the next step by formation of transition condition Gn (G0 to G4095) without waiting for the motion operating completion. If not formation of transition condition, transits to the right-connected step. When just before is the operation control step, transits to the next step by the completion of transition condition after operating execution. If not the completion of transition condition, transits to the right-connected step. When just before is "subroutine call" or "starting step", transits to the next step by the completion of transition condition without waiting for the operating of subroutine completion. If not formation of transition condition, transits to the right-connected step.
	WAIT Y/N	 (8)	<ul style="list-style-type: none"> When just before is the motion control step, waits for the motion operating completion and then transits to the next step by formation of transition condition Gn (G0 to G4095). If not completion of transition condition, transits to the right-connected step. When just before is the operation control step, transits to the next step by the completion of transition condition after operating execution. If not the completion of transition condition, transits to the right-connected step. (Same operation as Shift.) When just before is subroutine call or starting step, waits for the operating completion of subroutine, and then transits to the next step by the completion of transition condition. If not formation of transition condition, transits to the right-connected step.
Jump	Jump	 (14)	<p>Jumps to the specified pointer Pn (P0 to P16383) of the self program.</p>
Pointer	Pointer	 (8)	<ul style="list-style-type: none"> Indicates a jump destination pointer (label). This pointer can be set at a step, transition, branch point or coupling point. P0 to P16383 can be set in one program. The same No. may also be used in other programs.

*1 For operating system software version "09" or earlier, K0 to K4095.

3.3 Branch and Coupling Chart List

Branch and coupling patterns which specify step and transition sequences in the Motion SFC charts are shown below.

Classification	Name (Code size (byte))	Motion SFC chart symbol	Function
Basic type	Series transition (Corresponding symbol size)		<ul style="list-style-type: none"> Steps and transitions connected in series are processed in order from top to bottom. Steps and transitions need not be lined up alternately. When a transition is omitted, unconditional shift processing is performed.
	Selective branch ($(\text{Number of branches} + 2) \times 10$)		<ul style="list-style-type: none"> The route which transition condition enables first is executed after executing the step or transition preceding a branch. Selective branch destinations should always be started by transitions, all of which must be Shift or WAIT. (Using Shift and WAIT together will cause a parallel branch.)
	Selective coupling (8)		<ul style="list-style-type: none"> After the route branched by a selective branch has been processed, execution shifts to a coupling point. A coupling may be preceded and followed by either a step or a transition.
	Parallel branch ($\text{Number of branches} \times 22 + \text{number of coupling points} \times 2 + 12$)		<ul style="list-style-type: none"> Multiple routes (steps) connected in parallel are executed simultaneously. Each parallel branch destination may be started by either a step or transition.
	Parallel coupling (8)		<ul style="list-style-type: none"> Execution waits at the coupling point for executions of the routes branched by a parallel branch to be completed, and shifts to the next when executions of all routes are completed. A coupling may be preceded and followed by either a step or a transition. When this coupling is preceded by an FS step, scans are executed during waiting. After waiting is complete, scans are not executed.
	Jump transition (Corresponding symbol size)	<p>[Normal jump]</p> <p>[Coupling jump]</p>	<p>[Normal jump]</p> <ul style="list-style-type: none"> After the step or transition preceding this jump transition is executed, execution shifts to the pointer Pn specified within its own program. The jump destination may either be a step or transition. When a jump takes place from an FS step to a transition, scans are executed during waiting for the completion of transition condition of the jump destination. <p>[Coupling jump]</p> <ul style="list-style-type: none"> When a jump to the other route within a parallel branch takes place after the parallel branch, a "coupling jump" takes place and execution waits at the jump destination.

Combining the basic type branches/couplings provides the following application types, which are defined as in the basic types.

Classification	Name	Motion SFC chart symbol	Function
Application type	Selective branch Parallel branch		After a selective branch, a parallel branch can be performed.
	Parallel coupling Selective coupling		<ul style="list-style-type: none"> The selective coupling point can be the same as the coupling point of a parallel coupling for selective branch → parallel branch. Note that in the Motion SFC chart, this type is displayed in order of a parallel coupling → a selective coupling, as shown on the left. In this case, a pointer (Pn) cannot be set between the parallel coupling point (PAEm) and the selective coupling point (IFE m).
	Parallel branch Selective branch		After a parallel branch, a selective branch can be performed.
	Selective coupling Parallel coupling		<ul style="list-style-type: none"> The parallel coupling point can be the same as the coupling point of a selective coupling for parallel branch → selective branch. Note that in the Motion SFC chart, this type is displayed in order of a selective coupling → a parallel coupling, as shown on the left. In this case, a pointer (Pn) cannot be set between the selective coupling point (IFE m) and the parallel coupling point (PAEm).
	Selective branch Selective branch		After a selective branch, a selective branch can be performed.
	Selective coupling Selective coupling		<ul style="list-style-type: none"> The two selective coupling points for selective branch → selective branch can be the same. Note that in the Motion SFC chart, this type is displayed in order of a selective coupling → a selective coupling, as shown on the left. In this case, a pointer (Pn) cannot be set between the selective coupling point (IFE m+1) and the selective coupling point (IFE m).
	Parallel branch Parallel branch		<ul style="list-style-type: none"> After a parallel branch, a parallel branch can be performed. A parallel branch can be nested up to four levels.

Classification	Name	Motion SFC chart symbol	Function
Application type	Parallel coupling Parallel coupling		<ul style="list-style-type: none"> The two parallel coupling points for parallel branch parallel branch can be the same. Note that in the Motion SFC chart, this type is displayed in order of a parallel coupling → a parallel coupling, as shown on the left. In this case, a pointer (Pn) cannot be set between the parallel coupling point (PAEm+1) and the parallel coupling point (PAEm).
	Selective coupling Parallel branch		<ul style="list-style-type: none"> The selective coupling point and parallel branch point can be the same. Note that in the Motion SFC chart, this type is displayed in order of a selective coupling → a parallel branch, as shown on the left. In this case, a pointer (Pn) cannot be set between the selective coupling point (IFEm) and the parallel branch point (PABm).
	Parallel coupling Selective branch		<ul style="list-style-type: none"> The parallel coupling point and selective branch point can be the same. Note that in the Motion SFC chart, this type is displayed in order of a parallel coupling → a selective branch, as shown on the left. Execution waits at the parallel coupling point and shifts to the selective branch. In this case, a pointer (Pn) cannot be set between the parallel coupling point (PAEm) and the selective branch point (IFBm).
	Selective coupling Selective branch		<ul style="list-style-type: none"> The selective coupling point and selective branch point can be the same. Note that in the Motion SFC chart, this type is displayed in order of a selective coupling → a selective branch, as shown on the left. In this case, a pointer (Pn) cannot be set between the selective coupling point (IFEm) and the selective branch point (IFBm+1).
	Parallel coupling Parallel branch		<ul style="list-style-type: none"> The parallel coupling point and parallel branch point can be the same. Note that in the Motion SFC chart, this type is displayed in order of a parallel coupling → a parallel branch, as shown on the left. Execution waits at the parallel coupling point and shifts to the parallel branch. In this case, a pointer (Pn) cannot be set between the parallel coupling point (PAEm) and the parallel branch point (PABm+1).

3.4 Motion SFC Program Name

Set the "Motion SFC program name" to the Motion SFC program No.0 to No.511 (for operating system software version "09" or earlier, No.0 to No.255) individually. Set the Motion SFC program name within 16 characters. Specify this Motion SFC program name for a "subroutine call/start step (GSUB)" and "clear step (CLR)".

Point

- The Motion SFC program can be set to any No. from No.0 to No.511. There are no specific programs which have special roles.
 - "\$" cannot be used in the first character of the Motion SFC program name.
 - "\ / : ; , . * ? " < > |" cannot be used in Motion SFC program name.
-

3.5 Steps

Motion control step

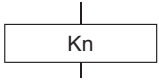
Name	Symbol	Setting range
Motion control step		K0 to K8191 ^{*1}

*1 For operating system software version "09" or earlier, K0 to K4095.

Processing details

- Turns on the start accept flag of the axis specified with the specified servo program Kn running.
- Starts the specified servo program Kn.

■ Execution timing

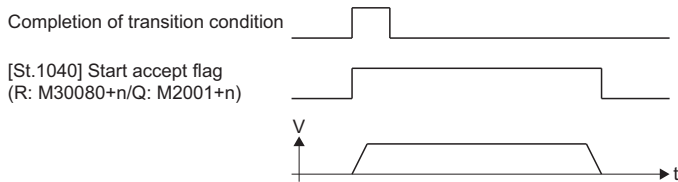

Operation error

When the specified servo program Kn does not exist, the minor error (SFC) (error code: 31F0H) will occur and stops to execute the Motion SFC program at the error detection.

Precautions

- When the current value change is executed in the Motion SFC program running, specify the CHGA instruction in the servo program and call it at the motion control step.
- If the servo program has stopped due to a minor error which occurred at or during a start of the servo program specified with the motion control step, the Motion SFC program continues executing. When the Motion SFC program is stopped at error detection, provide an error detection condition at the transition (transition condition).
- Refer to the following for servo programs that can be described in Motion control steps.
 MELSEC iQ-R Motion Controller Programming Manual (Positioning Control)

Operation control step

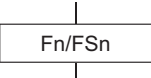
Name	Symbol	Setting range
Operation control step		F0 to F4095/FS0 to FS4095

Processing details

■ Once execution type operation control step Fn

In the case of Fn, executes the specified operation control program Fn once.

■ Scan execution type operation control step FSn

In the case of FSn, repeats the specified operation control program FSn until the next transition condition enables.

Operation error

When the specified operation control program Fn/FSn does not exist, the minor error (SFC) (error code: 31F1H) will occur and stops to execute the Motion SFC program at the error detection.

Precautions

- Refer to the operation control programs for operation expressions that may be described in operation control programs.
( Page 118 OPERATION CONTROL PROGRAMS)
- If an operation or similar error occurs the operation control program running, the Motion SFC program continues executing.

Subroutine call/start step

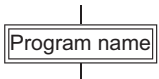
Name	Symbol	Setting range
Subroutine call/start step		The registered program name

Processing details

- Calls/starts the Motion SFC program of the specified program name.
- Control varies with the type of the transition coupled next to the subroutine call/start step.

■WAIT (Subroutine Call)

When the subroutine call step is executed, control transits to the specified program as shown below, and when END of the called program is executed, control returns to the call source program.

■Except WAIT (Subroutine Start)

When the subroutine start step is executed, control starts the specified program and then shifts to the next as shown below. Since, the start source and destination Motion SFC programs are executed in parallel. The started program ends at END execution.

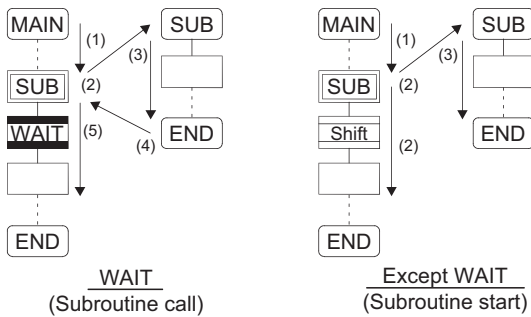

Operation error

- When the specified Motion SFC program does not exist at a subroutine call/start, the minor error (SFC) (error code: 32F5H) will occur and stops to execute the Motion SFC program at the error detection.
- When the called/started Motion SFC program is already starting at a subroutine call/start, the minor error (SFC) (error code: 32F6H) will occur and stops to execute the Motion SFC program at the error detection.
- When the self program is started at a subroutine call/start, the minor error (SFC) (error code: 33FAH) will occur and stops to execute the Motion SFC program at the error detection.
- When the subroutine to be called/started at a subroutine call/start in the Motion SFC program 2 running which was called/started from the Motion SFC program 1 is the Motion SFC program 1 (call source/start program), the minor error (SFC) (error code: 33FBH) will occur and the call/start source Motion SFC program 2 running is stopped at the point of error detection.

Precautions

- There are no restrictions on the depth of subroutine call/start nesting.
- For a subroutine start, the start source Motion SFC program continues processing if the start destination Motion SFC program stops due to an error.
- For a subroutine call, the call source Motion SFC program stops running as soon as the call destination Motion SFC program stops due to an error.

Clear step

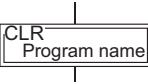
Name	Symbol	Setting range
Clear step		The registered program name

Processing details

- Stops the specified Motion SFC program running.
- The clear-specified Motion SFC program will not start automatically after stopped if it has been set to start automatically.
- The specified program may be its self program.
- If the specified program is being subroutine called, the subroutine program called is also stopped. (Shown below)

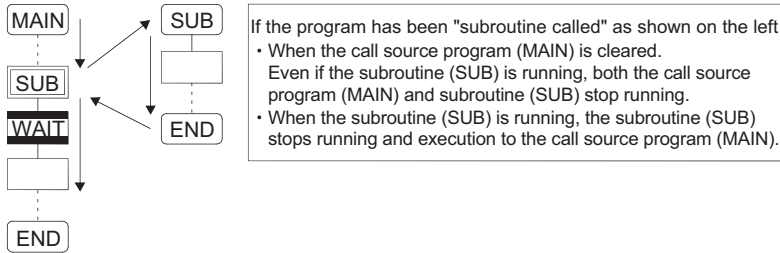

- When the specified program has been subroutine started, the subroutine program started continues processing. (Shown below)

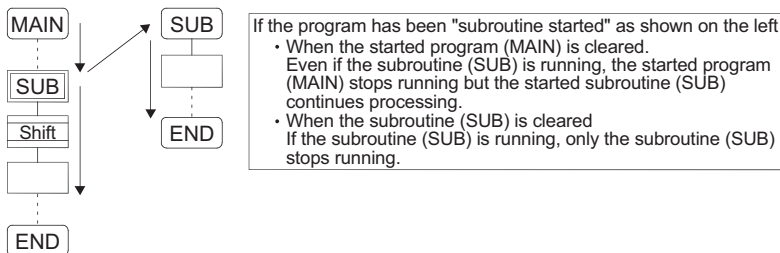

- When the servo program started from the specified program is starting, the servo program continues processing.
- The servo program is executed after waiting completion of condition in "WAITON/WAITOFF + motion control step". Input the stop command of target axis in addition not to execute the servo program.

Operation error

When a SFC program that does not exist is specified by clear step, an error occurs if the Motion SFC program is converted in MT Developer2.

Precautions

- When the Motion SFC program specified with the clear step is not starting, an error does not occur specifically and this step is ignored.
- If the Motion SFC program running is stopped by the clear step, the output is held.
- Input the stop command of target axis in addition to stop an operating axis with the clear step execution.

3.6 Transitions

You can describe conditional and operation expressions at transitions. The operation expression described here is repeated until the transition condition enables, as at the scan execution type operation step. Refer to the transition programs for the conditional/operation expressions that can be described in transition conditions. ( Page 283 TRANSITION PROGRAMS)

Combinations with motion control steps

Processing details

■ Motion control step + Shift

- Transits to the next step by formation of transition condition Gn without waiting for the operating completion of the servo program Kn started at the motion control step.

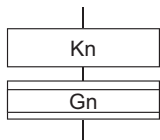

■ Motion control step + WAIT

- Waits for the operating completion of the servo program Kn started at the motion control step, and then transits to the next step by formation of transition condition Gn.
- The operation completion condition of the servo program Kn is not needed in the transition condition Gn.
- An error stop of the started servo program Kn at/during a start is also regarded as an operation completion.

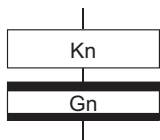

■ WAITON/WAITOFF + Motion control step

- Prepares for the start of the motion control step next to WAITON/WAITOFF, and makes a start immediately when the specified bit device turns ON/OFF. When the motion control step is executed without being used with WAITON/WAITOFF, preparations for a start are made after the transition condition preceding the motion control step enables. This will cause a variation of delay/starting time between when the transition condition is completed and when a start is made, but a combination with WAITON/WAITOFF can eliminate the variation of the above delay/starting time.
- Refer to the following for details of bit devices which can be set to WAITON/WAITOFF.

 MELSEC iQ-R Motion Controller Programming Manual (Common)

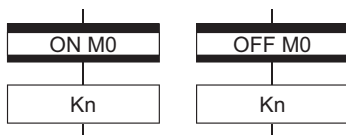

Precautions

- Always pair a transition with a motion control step one-for-one. If the step following WAITON/WAITOFF is not a motion control step, the minor error (SFC) (error code:33F2H) will occur and the Motion SFC program running will stop at the error detection.
- An error will not occur if the jump destination immediately after WAITON/WAITOFF is a motion control step. (Left below)
- A pointer may exist immediately after WAITON/WAITOFF. (Right below)

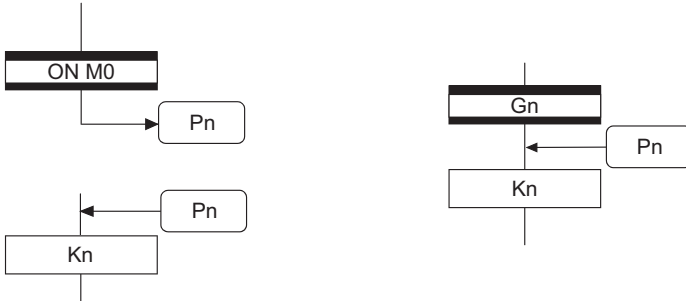

- If the servo program specified with a motion control step could not be started due to minor error, the Motion SFC program continues running and execution shifts to the next, independently of the WAITON/WAITOFF bit device status. To stop the Motion SFC program at error detection, provide an error detection condition at the next transition (transition condition).
- The following instructions can be used in the motion control step used combining the WAITON/WAITOFF. (Linear interpolation control, circular interpolation control, helical interpolation, position follow-up control, continuous trajectory control, high speed oscillation and speed control with fixed position stop.)

Combination with operation control step

Processing details

- At an operation control step, both Shift and WAIT perform the same operation, and after executing of the operation control program Fn, transits to the next step by formation of transition condition Gn.

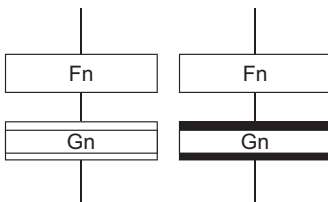

Combination with subroutine call/start step

Refer to the subroutine call/start step for the combination with subroutine call/start step. (☞ Page 102 Subroutine call/start step)

3.7 Jump, Pointer

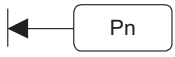
Name	Symbol	Setting range
Jump		P0 to P16383
Pointer		P0 to P16383

Processing details

- Setting a jump will cause a jump to the specified pointer Pn of the self program.
- You can set pointers at steps, transitions, branch points and coupling points.
- You can set pointers Pn at P0 to P16383 in one program.

Precautions

- You cannot make a jump setting which will exit from within parallel branch-parallel coupling. Connect directly. (Bad example 1 given below)
- You cannot make a jump setting from outside parallel branch-parallel coupling to within parallel branch-parallel coupling. (Bad example 2 given below)
- You cannot make a setting where a label and a jump will continue. (Bad example 3 given below)

Bad example 1

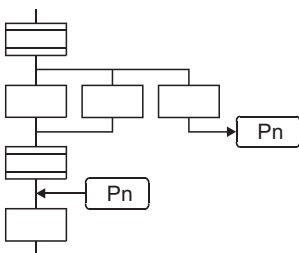

Bad example 2

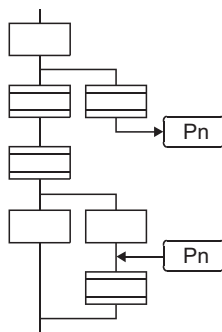

Bad example 3

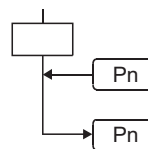

3.8 END

Name	Symbol	Setting range
END		—

Processing details

- Ends a program. (In this case of an event task or NMI task, operation changes with end operation setting of the program parameter. (📖 Page 295 Program Parameters)
- Making a subroutine call will return to the call source Motion SFC program.

Precautions

- END may be set a multiple number of times in one program.
- END cannot be set between a parallel branch and a parallel coupling.
- The output is held after the Motion SFC program is ended by END.

3.9 Branches, Couplings

Series transition

Transits execution to the subsequent step or transition connected in series. To start a servo program or subroutine and transit to the next step, set a shift, or a WAIT at a transition.

To transit to the next step without waiting for operation completion

Set Shift at a transition. In this case, the transition (shift) may be omitted. When you omitted the transition, an unconditional shift transition is performed.

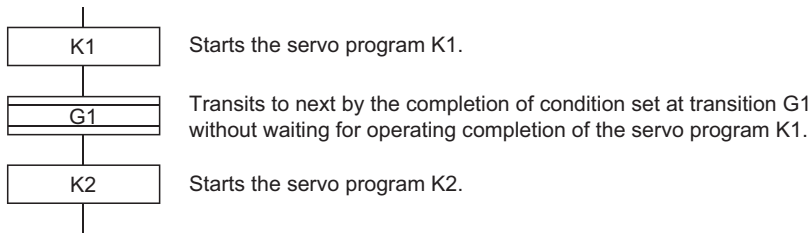

Point

For a subroutine start, self program and a subroutine program are processed in parallel.

To proceed to the next step on operation completion

Set WAIT at a transition.

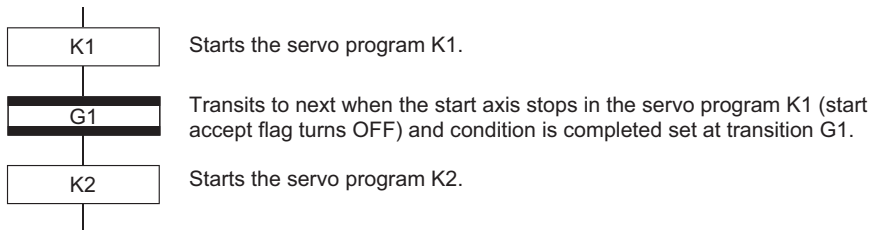

Point

- The above start accept flag of the axis started in the next servo program K2 is not included in interlocks. To use it as an interlock, the user should set it in the transition condition G1.
- WAIT must be set to proceed to the next step on operation completion. However, when there are specifically no conditions to be set as interlocks, set "NOP (No Operation)" in the transition program (Gn).

Selective branch, selective coupling

Selective branch

Executes only the route which condition was judged to have enabled first among the conditions of multiple transitions connected in parallel. Transitions must be all Shifts or WAITs.

Ex.
WAIT

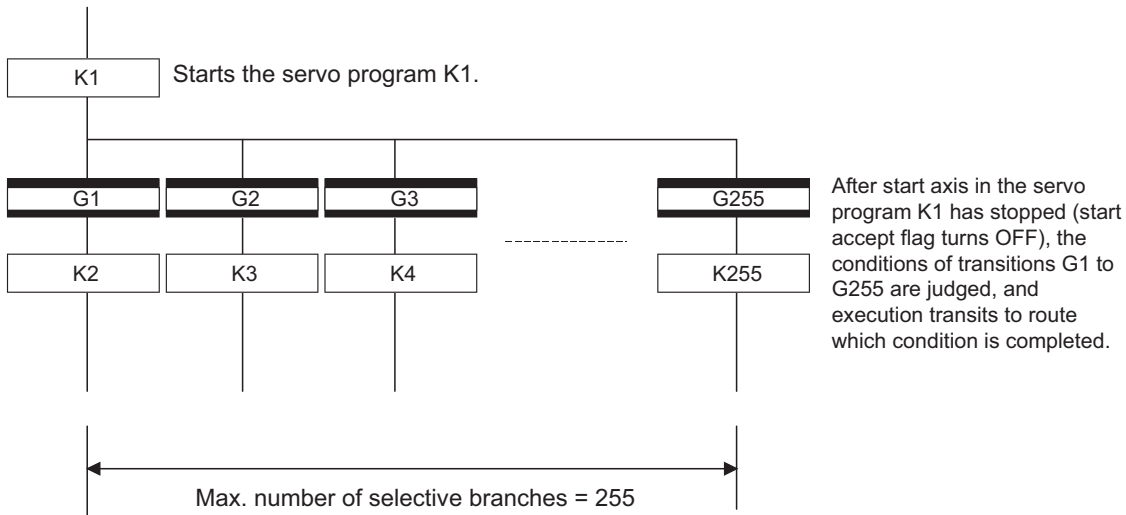

Point

- Transition condition judgment is not always executed from left to right.
- Using Shift and WAIT together will cause a parallel branch.
- When judging transition condition by selective branch, the number of multi active steps is "number of selective branches + 1". If the number of selective branches is 255, the number of multi active steps is 256.

Selective coupling

Recoupling of routes into a single route after their processing completions following a selective branch will be a selective coupling. However, you can also make a setting where no coupling will be made as shown below.

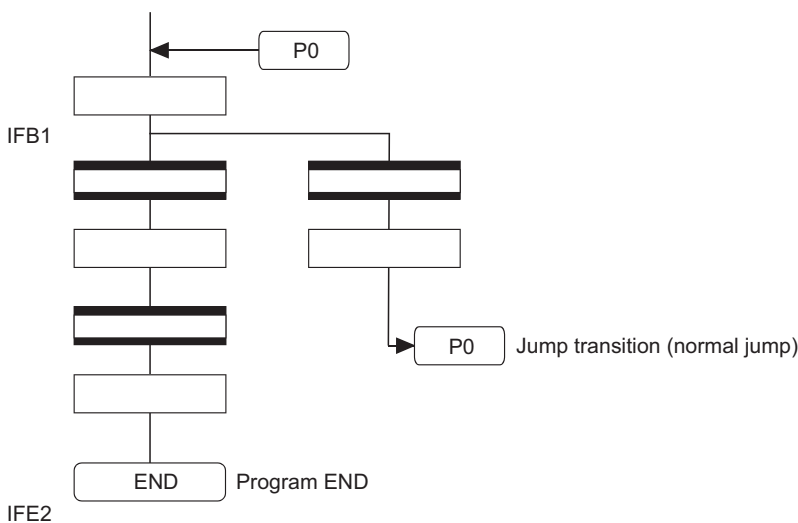

Parallel branch, parallel coupling

Parallel branch

Multiple routes connected in parallel are executed simultaneously. Each parallel branch destination may be started by either a step or a transition.

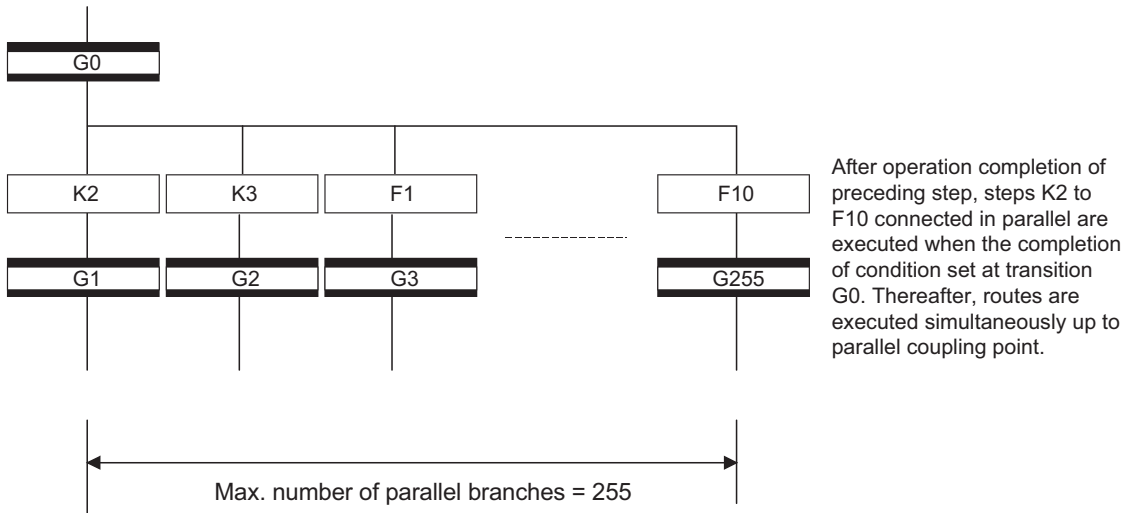

Point

"Shift" or "WAIT" can be set to a transition preceding a parallel branch. "WAITON" and "WAITOFF" cannot be set.

Parallel coupling

A parallel branch must be coupled by a parallel coupling. A jump setting to another branch route can be made within parallel branch-parallel coupling. In this case, a jump destination is a midway parallel coupling point (coupling jump). You cannot set a jump to exit from within parallel branch-parallel coupling.

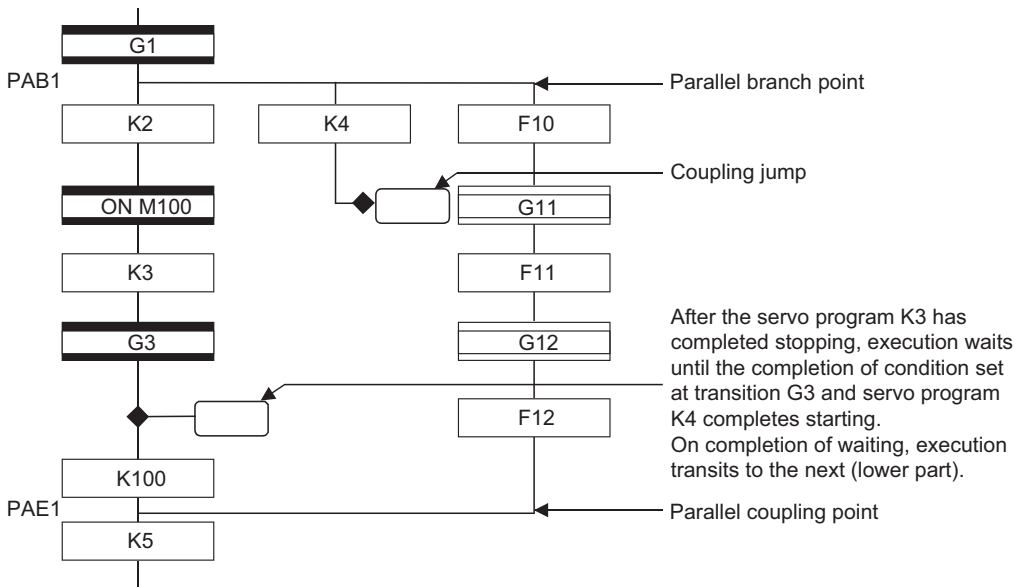

Point

The number of parallel branches need not match that of couplings at a parallel coupling point. (In the example of the diagram above, the number of parallel branches is 3 and that of couplings is 2.)

When a WAIT transition is set right after a parallel coupling, the stop completions of the axes are not included in the waiting conditions if the parallel coupling is preceded by motion control steps. To perform a parallel coupling on stop completions, set WAIT transitions before a parallel coupling.

(×)

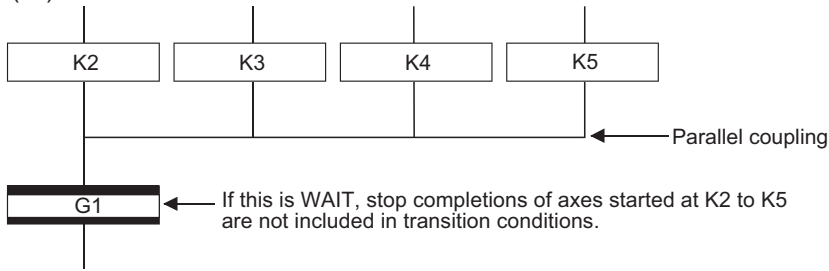

(○)

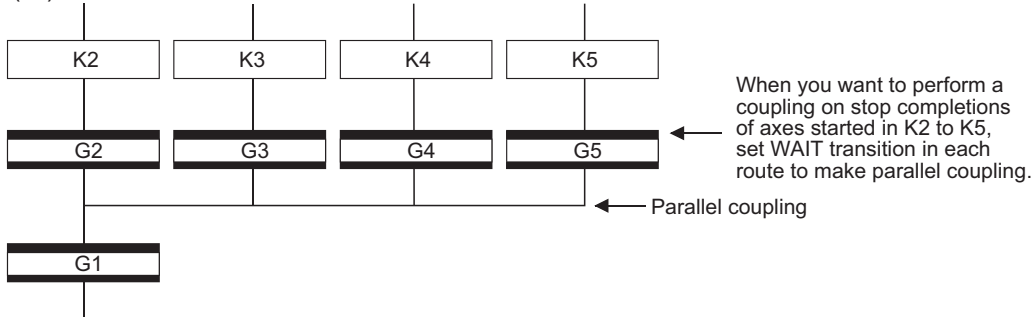

3.10 Y/N Transitions

When routes are branch at a transition condition enables and disable, "Shift Y/N transition" or "WAIT Y/N transition" will be useful.

Name	Symbol	Function
Shift Y/N transition		<ul style="list-style-type: none"> When a transition condition set at Gn enables, execution shifts to the lower step. When that condition disables, execution shifts to the right-connected step. Differences between "Shift Y/N" and "WAIT Y/N" are the same as those between "Shift" and "WAIT".
WAIT Y/N transition		

A Y/N transition is designed to describe the following two-route selective branch program easily.

[Y/N transition is not used]

- G0 and G1 programs should be different only in acknowledgement/negation of the conditional expressions.

(Example 1)

[G 0] M0	[G 0] !M0
-------------	--------------

(Example 2)

[G 0] D0=K100	[G 0] D0=K100
------------------	------------------



[Y/N transition is used]

- Set the G0 program shown in above (Example 1) or (Example 2) as a G0 program.
- The Motion SFC program list codes after conversion are the same as in the conventional description (different only in the Motion SFC chart representation). Therefore, "automatic search for free G number → automatic generation of program which conditional expression part is logically negated" is performed during program editing to occupy two G programs. Using "Program editor" to delete a Y/N transition does not delete the automatically generated G program (G1 below). Use "Program use list" to delete that program.

Automatic free G number search feature

■When not set to automatic numbering

Searches for a free number forward, starting with the "set G number + 1" at the "Shift Y/N" or "WAIT Y/N" symbol. When no free numbers are found after a search up to 4095, a search is made from 0 to the "set G number - 1".

■When set to automatic numbering

Searches for a free number forward (or backward) in the automatic numbering range, starting with the "automatically numbered G number + 1 (or -1)" at the "Shift Y/N" or "WAIT Y/N" symbol. (The searching method is as in the automatic numbering setting.)

Automatic logical NOT program generation feature

Automatically generates a program which logically negates the conditional expression block (last block) of the transition program set at "Shift Y/N" or "WAIT Y/N". The basic is shown below.

[Setting program (conditional expression block)]

Conditional expression //(bit conditional expression or comparison conditional expression)



[Logically negated, automatically generated program (conditional expression block)]

!Conditional expression //(bit conditional expression or comparison conditional expression)

Examples are shown below.

[Setting program (conditional expression block)]

(Example 1)

M0 //Bit device ON

(Example 2)

D0!=K100 //Data register D0 is not K100

[Logically negated, automatically generated program (conditional expression block)]

(Example 1)

!(M0) //Bit device OFF

(Example 2)

!(D0!=K100) //Data register D0 is K100

Point

- Refer to the table of the operation control/transition instruction for the instructions usable in the conditional expressions of "Shift Y/N" or "WAIT Y/N" transition programs. (☞ Page 23 Table of the operation control/transition instruction)
- Set conditional expression block only to the setting program.
- For Y/N transitions, there are 2 transition condition judgments by selective branching, therefore the number of multi active steps is 3 steps.

Instructions for the Motion SFC charts

Any Motion SFC chart that will be meaningless to or conflict with the definition of Y/N transitions will result in an error at the time of editing (or Motion SFC chart conversion). Their patterns and instructions will be given below.

■When "Shift Y/N" or "WAIT Y/N" is connected as a selective branch or parallel branch

The following patterns result in an error

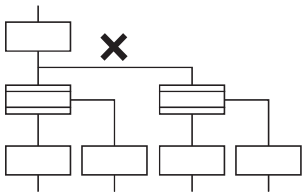
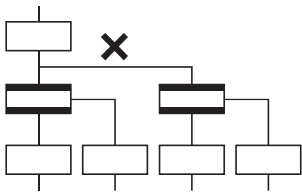
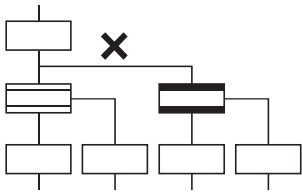
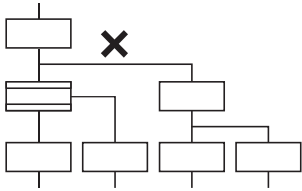
Description	Motion SFC chart pattern
"Shift Y/N" used as selective branch	
"WAIT Y/N" used as selective branch	
"Shift Y/N" and "WAIT Y/N" used as parallel branch	
"Shift (or WAIT) Y/N" used with other step/transition as parallel branch or selective branch	

■When a coupling precedes "Shift Y/N" or "WAIT Y/N"

Provide "coupling-branch continuation" in between.

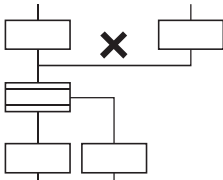
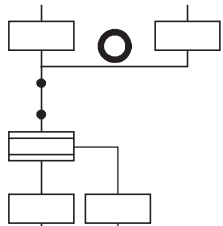
Description	Motion SFC chart pattern
Direct coupling with "Shift Y/N" or "WAIT Y/N" is not allowed.	
Provide "coupling-branch continuation" in between.	





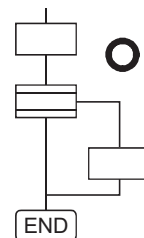
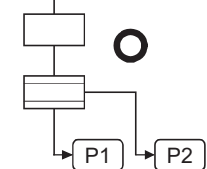
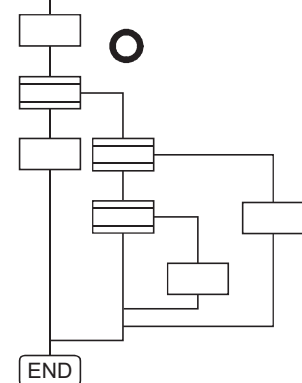
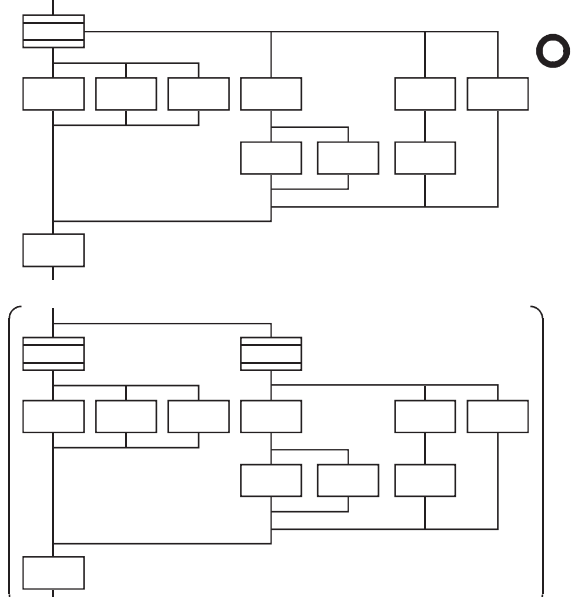

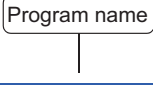
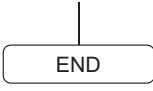
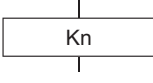
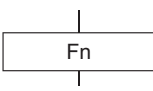

■Patterns that may be set

The following patterns may be set.

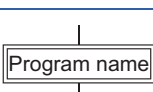
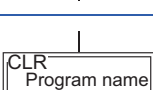
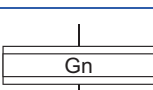
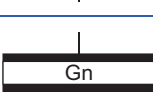
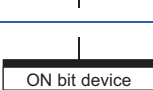
Description	Motion SFC chart pattern
End (END) from "Shift Y/N" or "WAIT Y/N"	 <p>The diagram shows a vertical sequence of three states. The top state is a simple rectangle. The middle state is a rectangle with a horizontal line through its center. A transition line goes from the bottom of the middle state to the top of the bottom state, which is a rounded rectangle labeled "END". A small circle is located to the right of the middle state.</p>
Jump from "Shift Y/N" or "WAIT Y/N"	 <p>The diagram shows a vertical sequence of two states. The top state is a simple rectangle. The bottom state is a rectangle with a horizontal line through its center. A transition line goes from the bottom of the top state to the top of the bottom state. From the right side of the bottom state, two parallel transition lines lead to two parallel states labeled "P1" and "P2". A small circle is located to the right of the top state.</p>
Continuation from "Shift Y/N" or "WAIT Y/N" to "Shift Y/N" or "WAIT Y/N" (selective branch-selective branch)	 <p>The diagram shows a vertical sequence of four states. The top state is a simple rectangle. The second state is a rectangle with a horizontal line through its center. A transition line goes from the bottom of the second state to the top of the third state, which is a simple rectangle. From the right side of the third state, two parallel transition lines lead to two parallel states. From the bottom of the first of these parallel states, a transition line goes to the top of the fourth state, which is a rectangle with a horizontal line through its center. A small circle is located to the right of the top state.</p>
When there are two or more connection lines from Y/N side of "Shift Y/N" or "WAIT Y/N", selective branch continues to selective branch or parallel branch.	 <p>The diagram shows a vertical sequence of two states. The top state is a rectangle with a horizontal line through its center. A transition line goes from the bottom of the top state to the top of the bottom state, which is a simple rectangle. From the right side of the bottom state, two parallel transition lines lead to two parallel states. From the bottom of the first of these parallel states, a transition line goes to the top of the second parallel state. A small circle is located to the right of the top state. The entire diagram is enclosed in large parentheses.</p>

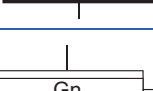
3.11 Motion SFC Comments

A comment can be set to each symbol of the step/transition in the motion SFC chart. Comments are shown in the Motion SFC chart by changing the display mode to "Comment display" on the Motion SFC program edit screen.

Classification	Name	Symbol	Comment Setting
Program start/end	START		Comment setting cannot be made.
	END		
Step	Motion control step		Up to 80 characters Displayed in 20 characters × 4 lines
	Once execution type operation control step		
	Scan execution type operation control step		
	Subroutine call/start step		
	Clear step		
Transition	Shift (preread transition)		
	WAIT		
	WAITON		
	WAITOFF		
	Shift Y/N		
	WAIT Y/N		
Jump	Jump		Up to 64 characters Displayed in 16 characters × 4 lines
Pointer	Pointer		

Point 

-
- Motion SFC comments are stored into the code area of Motion CPU. The code area stores the Motion SFC chart codes, operation control (F/FS) program codes, transition (G) program codes and Motion SFC comments. Be careful not to set too many comments to avoid code area overflow. (Refer to Motion SFC performance specifications for the code area sizes.) ( Page 20 Motion SFC performance specifications))
 - You cannot use "," in comment statements.
-

4 OPERATION CONTROL PROGRAMS

4.1 Operation Control Programs

Operation control programs

- Substitution operation expressions, motion-dedicated functions and bit device control commands can be set in operation control program.
- Multiple blocks in one operation control program can be set.
- There are no restrictions on the number of blocks that may be set in one operation control program. However, one program is within 128k bytes.
- The maximum number of characters in one block is 1020.
- Transition conditions cannot be set. Transition conditions can be set only in transition programs.
- The bit conditional expression that logical data value (true or false) is returned in an operation control program, a comparison conditional expression can be set up only as a source (S) of device set (SET=) or device reset (RST=).

An operation control program example is shown below.

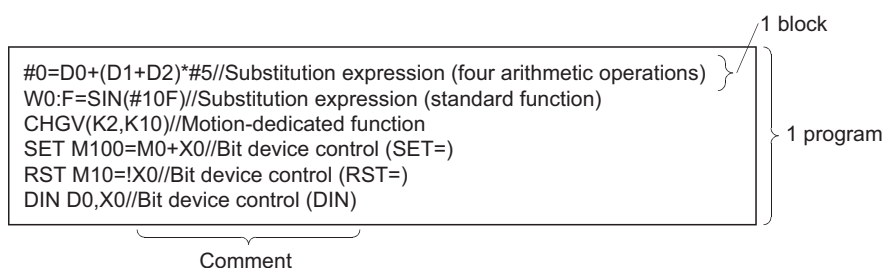

Priorities of operators and functions

Operators and functions have the following priorities. Using parentheses allows an operation sequence to be specified freely.

Priority		Item (Operator, Function)
High	1	Calculation within parentheses ((...))
↑	2	Standard function (SIN, COS, etc.), Type conversion (USHORT, LONG, etc.)
↓	3	Bit inversion (~), logical negation (!), sign inversion (-)
Low	4	Multiplication (*), division (/), remainder (%)
	5	Addition (+), subtraction (-)
	6	Bit left shift (<<), bit right shift (>>)
	7	Comparison operators: Less than (<), less than or equal to (<=), more than (>), more than or equal to (>=)
	8	Comparison operators: Equal to (==), not equal to (!=)
	9	Bit logical AND (&)
	10	Bit exclusive OR (^)
	11	Bit logical OR ()
	12	Logical AND (*)
	13	Logical OR (+)
	14	Substitution (=)

Structure of instruction

Many of the instructions usable in operation control programs can be divided into instruction and data parts. The instruction and data parts are used for the following purposes.

- Instruction part: Indicates the function of that instruction.
- Data part: Indicates the data used in the instruction.

Ex.

"Substitution: =" structure example

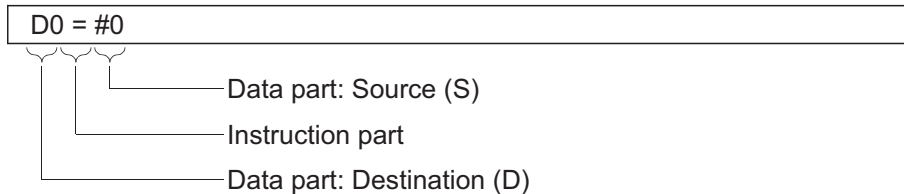

■Source (S)

- The source is the data used in an operation.
- It varies with the device specified in each instruction is shown below.

Device	Description
Bit or word device	Specify the device which stores the data used in operation. The data must have been stored in the specified device until the operation is executed. Changing the data stored in the specified device during program execution allows changing the data used in that instruction.
Constant	Specify the numerical value used in an operation. As the constant is set during program creation, it cannot be changed during program running.

■Destination (D)

- As the destination data, after-operation data is stored.
- Destination data is always set the device for storing the data.

How to specify data

There are the following six different data usable in each instruction.

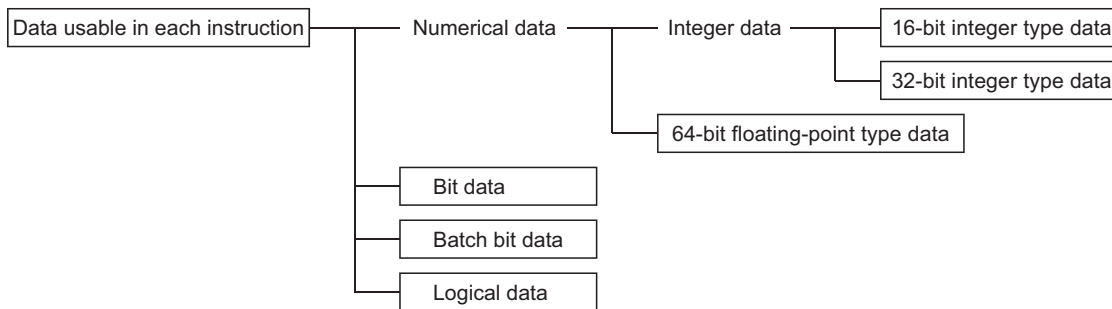

■16-bit integer type data

The 16-bit integer type data is 16-bit integer value data. Word devices are used in increments of 1 point. Data ranges are shown below.

	Decimal representation	Hexadecimal representation
Data range	K-32768 to K32767	H0000 to HFFFF

■32-bit integer type data

The 32-bit integer type data is 32-bit integer value data. Word devices are used in increments of 2 points: (specified device No.), (specified device No. + 1). Data ranges are shown below.

	Decimal representation	Hexadecimal representation
Data range	K-2147483648L to K2147483647L	H00000000L to HFFFFFFFL

■64-bit floating-point type data

The 64-bit floating-point type data is IEEE-formatted, 64-bit floating-point value data. Word devices are used in increments of 4 points: (specified device No.), (specified device No.+1), (specified device No.+2), (specified device No.+3).

- The internal bit locations are shown below.

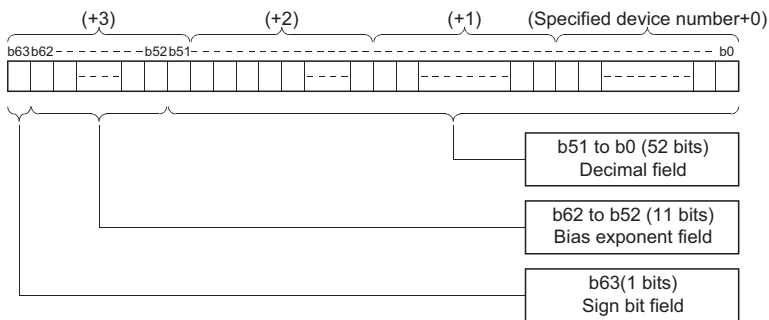

- The represented value is shown below. (The bias value is H3FF.)
 $(-1)^{[\text{Sign bit field}]} \times (1.0 + [\text{decimal field}]) \times 2^{([\text{Bias exponent field}] - [\text{bias value}])}$
- Data ranges are shown below.

	Decimal representation	Hexadecimal representation
Data range	K-1.79E+308 to K-2.23E-308, K0.0, K2.23E-308 to K1.79E+308	H0000000000000000, H0010000000000000 to H7FE1CCF385EBC89F, H8000000000000000, H8010000000000000 to HFFE1CCF385EBC89F

- A round-off error may be produced in a 64-bit floating-point type data operation. Especially when using 64-bit floating-point type data in a comparison operation, note that a round-off error may cause an unintended operation.

Ex.

In the following transition program, the result of the comparison operation may not become true depending on the value of #200F due to a round-off error.

```
#100F=SQRT(#200F)
#300F=#100F*#100F
#200F==#300F
```

■Bit data

The bit data is the data where a contact/coil or similar device is handled in increments of 1 bit. It is used in device set (SET=) and device reset (RST=). Example 1

Ex.

```
SET M0
```

└── Bit data

■Batch bit data

The batch bit data is the data where bit data is handled in increments of 16/32 points. It is used in device input (DIN) and device output (DOUT).

As indicated below, whether the bit data is handled in increments of 16 or 32 points is governed by the data type of the word device used as an input destination/output source.

	Increments of 16 points	Increments of 32 points
Program example	DIN #0,M0 DOUT M0,D0	DIN #0L,M0 DOUT M0,D0L
Used devices	(Specified device No.) to (specified device No. + 15) M0 to M15 in the above program example	(Specified device No.) to (specified device No. + 31) M0 to M31 in the above program example

■ Logical data

The logical data is a value returned by a bit or comparison conditional expression and indicates whether the result is true or false. Normally, it is used in the conditional expression of a transition program. In an operation control program, the logical data is used in a bit conditional expression set to device set (SET=) or device reset (RST=).

Ex.

(Example 1)

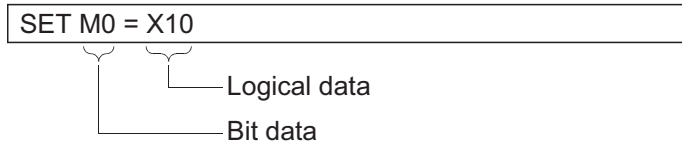

(Example 2)

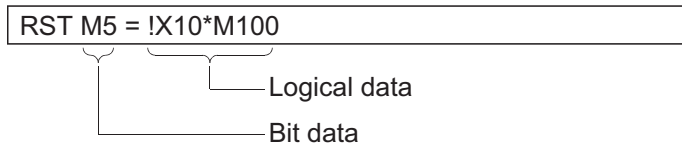

(Example 3) Transition program

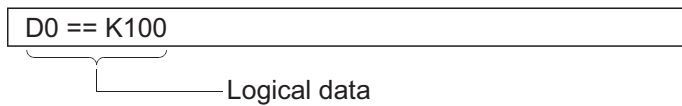

Internal operation data types

For internal operations, when (S1) and (S2) differ in data type, the data of the smaller type is converted into that of the greater type before operation is performed. If the operation result is over the range of processed number in each type, an overflow will occur. However, an operation error will not occur. By converting the set data with the type converting instruction, an overflow may be able to be prevented.

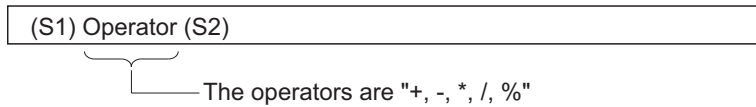

The data type combinations, and internal operation data types for binary operations are shown below.

(S1) data type	(S2) data type	Internal operation data type
16-bit integer type	16-bit integer type	16-bit integer type
	32-bit integer type	32-bit integer type
	64-bit floating-point type* ¹	64-bit floating-point type* ¹
32-bit integer type	16-bit integer type	32-bit integer type
	32-bit integer type	
	64-bit floating-point type* ¹	64-bit floating-point type* ¹
64-bit floating-point type	16-bit integer type	64-bit floating-point type* ¹
	32-bit integer type	
	64-bit floating-point type* ¹	

*¹ Except the operator "%"

Program example

- Program which substitutes the result of multiplying #0 by #10 to W0L

W0L = #0*#10

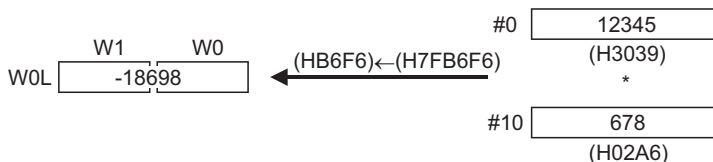

Since both of set data are the 16-bit integer type, the multiplier result is processed by the 16-bit integer type. An overflow occurs, and the lower 16-bit of the multiplier result is the operation result.

- Program which substitutes the result of multiplying #0 and #10 to W0L after converting into the 32-bit integer type

W0L = LONG(#0)*LONG(#10)

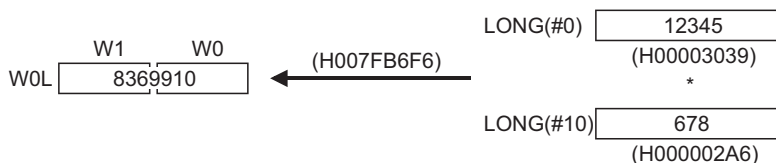

Since the multiplier result is processed with the 32-bit integer type by the type converting instruction, even if the device value is the same as the program example above (Program which substitutes the result of multiplying #0 by #10 to W0L), an overflow will not occur.

4.2 Device Descriptions

Word and bit device descriptions are shown below.

Word device descriptions

Device name	Device descriptions ^{*1}		
	16-bit integer type	32-bit integer type ("n" is even No.)	64-bit floating-point type ("n" is even No.)
Data register	Dn	DnL	DnF
Link register	Wn	WnL	Wn:F
Special register	SDn	SDnL	SDnF
Motion register	#n	#nL	#nF
CPU buffer memory access device	U3E□\Gn ^{*2}	U3E□\GnL ^{*2}	U3E□\GnF ^{*2}
CPU buffer memory access device (fixed scan communication area)	U3E□\HGn ^{*2}	U3E□\HGnL ^{*2}	U3E□\HGnF ^{*2}
Module access device	U□\Gn ^{*3}	U□\GnL ^{*3}	U□\GnF ^{*3}

*1 Refer to the following for the setting range of usable device numbers(n).

📖 MELSEC iQ-R Motion Controller Programming Manual (Common)

*2 □ = CPU number (CPU No.1: 0, CPU No.2: 1, CPU No.3: 2, CPU No.4: 3). A CPU number that exceeds the number of CPUs in Multiple CPU system cannot be set.

*3 □ = 00h to FFh (Module I/O number ÷ 10h). The accessible range differs depending on the module. Refer to the manual of the module used for details.

- For differentiation, the 32-bit floating-point type is ended by L and the 64-bit floating-point type by F ("F" for the link register).
- For the 32-bit integer type and 64-bit floating-point type, specify the device number with an even number. (It cannot be set as an odd number.)

Bit device descriptions

Device name	Device description ^{*1}
Input relay	Xn
Output relay	Yn
Internal relay	Mn
Link relay	Bn
Annunciator	Fn
Data register	Dn.m ^{*2}
Link register	Wn.m ^{*2}
Motion register	#n.m ^{*2}
Special relay	SMn
Special register	SDn.m ^{*2}
CPU buffer memory access device	U3E□\Gn.m ^{*2*3}
CPU buffer memory access device(fixed scan communication area)	U3E□\HGn.m ^{*2*3}
Module access device	U□\Gn.m ^{*3*4}

*1 Refer to the following for the setting range of usable device numbers(n).

📖 MELSEC iQ-R Motion controller Programming Manual (Common)

*2 "m" indicates a word device bit specification (bit number: 0 to F).

*3 □ = CPU number (CPU No.1: 0, CPU No.2: 1, CPU No.3: 2, CPU No.4: 3).

A CPU number that exceeds the number of CPUs in Multiple CPU system cannot be set.

*4 □ = 00h to FFh (Module I/O number ÷ 10h).

The accessible range differs depending on the module. Refer to the manual of the module used for details.

- When using the device in DIN or DOUT as batch bit data, specify "n" as a multiple of 16.
- When using the following device as batch bit data, specify it as word device without making bit specification.

Device name
Data register (D)
Link register (W)
Motion register (#)
Special register (SD)
CPU buffer memory access device (U3E□\G)
CPU buffer memory access device (fixed scan communication area) (U3E□\HG)
Module access device (U□\G)

Indirect specification of device No.

In word/bit device descriptions, device No. (n) can be specified indirectly.

■ Indirect specification of device No. (n) using word device

- The word device which the device No. was specified indirectly cannot be used.
- You can use the 16-bit and 32-bit integer type word devices for indirect specification. The 64-bit floating-point type cannot be used.
- The word devices that can indirectly specify device No.(n) are shown below.
 - Data register (D)
 - Link register (W)
 - Motion register (#)
 - Special register (SD)

Ex.

Description examples

Good example	Bad example
#(D10)	#(D(D5))
D(#10L)F	D(#4F)
#(D10).1	#10.(D5)

■ Indirect specification of device No. (n) using word device using operation expression

- Device No. can be specified indirectly by calculation expressions which use the following data and operators.

Usable data	16-bit integer type word device
	32-bit integer type word device
	16-bit integer type constant
	32-bit integer type constant
Usable operators	Addition: +
	Subtraction: -
	Multiplication: *
	Division: /
	Remainder: %
	Sign inversion: -

- The word device which the device No. is specified indirectly cannot be used.

Ex.

Description examples

Good example	Bad example
#(D10-K5)	#(D(D5)F+K20)
D(#10L%H6L)F	D(#4L<<K2)
D(K640+K2*K31)L	D(M0*#10.F)

*1 When you want to use the result of calculation other than the above to specify the device No. indirectly, describe it in two blocks as shown below.

```
D0 = SHORT(ASIN(#0F))
W0 = #(D0)
```

4.3 Constant Descriptions

The constant descriptions of the 16-bit integer type, 32-bit integer type and 64-bit floating-point type are shown below.

Representation	16-bit integer type	32-bit integer type	64-bit floating-point type
Decimal representation	K-32768 to K32767	K-2147483648L to K2147483647L	K-1.79E+308 to K-2.23E-308, K0.0, K2.23E-308 to K1.79E+308
Hexadecimal representation	H0000 to HFFFF	H00000000L to HFFFFFFFFL	—

- The 32-bit integer type is ended by L and the 64-bit floating-point type is provided with a decimal point and exponent part (E) to denote their data types explicitly.
- The constant without the data type is regarded as the applicable minimum type.
- The constant in decimal representation is headed by K and the one in hexadecimal representation by H. K can be omitted.
- The 64-bit floating-point type cannot be represented in hexadecimal.

4.4 Labels

A label is a variable consisting of a specified character string used in I/O data or internal processing. Using labels in programming enables creation of programs without being aware of devices. For this reason, a program using labels can be reused easily even in a system having a different module configuration.

Types

Labels

A label provides the same data within a single project. It can be used in all programs in the project. The settings of a label include a label name, and data type. By opening labels, they can be referenced from GOT, and can be used for monitoring and accessing data. When programming with labels for input and output devices, assign the labels to the devices directly.

Point

The following types of labels are available.

- System label

A system label is a label that provides the same data in all projects compatible with iQ Works. It can be referenced from the GOT and the CPU modules on other stations, and used for monitoring and accessing data. For details, refer to the following.

 Let's start iQ Works

Data types

The data types of a label are classified according to the bit length, processing method, and value range. The types are shown below.

Primitive data type

The following table lists the data types included in the primitive data type.

Data type	Description	Value range	Bit length	
Bit	BOOL	Represents the alternative status, such as ON or OFF.	0 (FALSE), 1 (TRUE)	1 bit
Word [unsigned]/bit string [16 bits]	WORD	16-bit array.	0 to 65535	16 bits
Double word [unsigned]/bit string [32 bits]	DWORD	32-bit array.	0 to 4294967295	32 bits
Word [signed]	INT	Positive and negative integer values.	-32768 to 32767	16 bits
Double word [signed]	DINT	Positive and negative double-precision integer values.	-2147483648 to 2147483647	32 bits
Double-precision real number	LREAL	Numerical values of decimal places (double-precision real number values).	K-1.79E+308 to K-2.23E-308, K0.0, K2.23E-308 to K1.79E+308	64 bits

Point

When using double word [unsigned]/bit string [32 bits], double word [signed], double-precision real number data types, use an even number device.

Arrays

An array represents a consecutive aggregation of same data type labels as a single name.

Primitive data types and structures can be defined as arrays.

The maxim number of array elements varies depending on the data type.

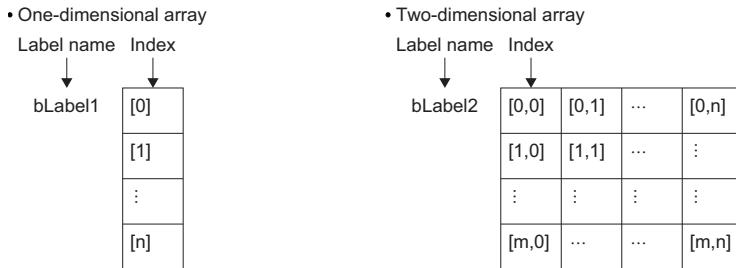

Defining arrays

■ Array elements

When an array is defined, the number of elements, or the length of array, must be determined.

■ Definition format

The following table lists definition format examples up to three dimensions.

The range from the array start value to the array end value is the number of elements.

Number of array dimensions	Format	Remarks
One dimension	Array of primitive data type/structure name (array start value..array end value) [Definition example] Bit (0..2)	<ul style="list-style-type: none"> Refer to primitive data type for details on primitive data type (Page 127 Primitive data type) Refer to structures for details on structures (Page 129 Structures)
Two dimensions	Array of primitive data type/structure name (array start value..array end value, array start value..array end value) [Definition example] Bit (0..2, 0..1)	
Three dimensions	Array of primitive data type/structure name (array start value..array end value, array start value..array end value, array start value..array end value) [Definition example] Bit (0..2, 0..1, 0..3)	

How to use arrays

To use an array, add an index enclosed by "[]" after each label name to identify individual labels.

An array with two or more dimensions should be represented with indexes delimited by a comma (,) in "[]".

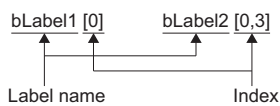

The following table lists the types of indexes that can be specified for arrays.

Type	Specification example	Remarks
Constant	bLabel1[0]	An integer can be specified.
Device	bLabel1[D0]	A word device, double-word device, decimal constant, or hexadecimal constant can be specified. (Data register(D), Link register(W), and Motion register(#) devices can be used.)

- The data storage location becomes dynamic by specifying a device for the array index. This enables arrays to be used in a program that executes loop processing. The following is a program example that consecutively stores "1234" in the "uLabel4" array.

```
FOR #0 = K0 TO K9 STEP K1
  uLabel4[#0] = K1234
NEXT
```

- When the device number of a device assigned to a label exceeds 32767, specify a 32 bit integer device to the index.

(Example)

Assigning "D32000" to the start device of label array "uLabel4", and also accessing D32768 onwards by specifying "#0" to the index of the array.

```
uLabel4[#0L]
```

Precautions

■When an event task is used

When a device is specified for the array index, the operation is performed with a combination of multiple instructions. For this reason, if an interrupt occurs during operation of the label defined as an array, data inconsistency may occur producing an unintended operation result.

To prevent data inconsistency, perform one of the following.

- Do not change the device being used as the index in a normal task during the event task.
- Use the DI/EI instructions that disables/enables event tasks before and after using the label defined in the array.

■Array elements

When accessing the element defined in an array, access it within the range of the number of elements.

If a constant out of the range defined for the array index is specified, an error will occur when converting the Motion SFC program.

If the array index is specified with data other than a constant, an error will not occur when converting the Motion SFC program. The processing will be performed by accessing another device.

Structures

A structure is a data type containing one or more labels and can be used in all programs.

Members (labels) included in a structure can be defined even when their data types are different.

Creating structures

To create a structure, first define the structure, and then define members in the structure.

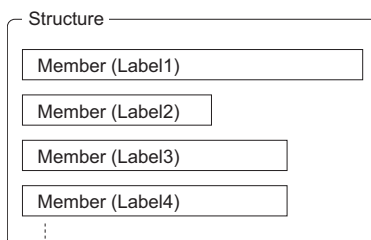

How to use structures

To use a structure, register a label using the defined structure as the data type.

To specify each member in a structure, add the member name after the structure label name with a period '.' as a delimiter in between.

Ex.

Specifying a member in the structure

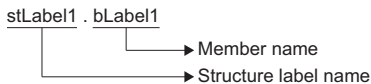

Point

When using double word [unsigned]/bit string [32 bits], double word [signed], double-precision real number data types in structures, make sure that even number devices are used in all members that use those data types.

Structure arrays

A structure can also be used as an array.

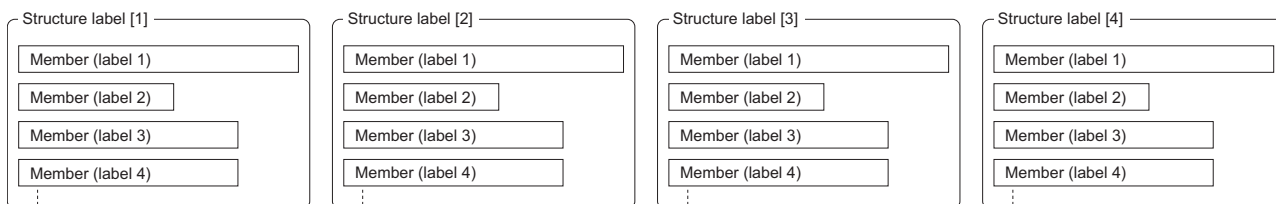

When a structure is declared as an array, add an index enclosed by "[]" after the structure label name.

Ex.

Specifying an element of a structure declared as an array

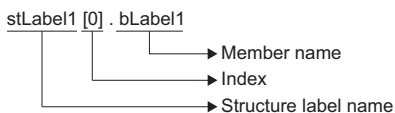

Data types that can be specified

Primitive data types can be specified as structure members.

Point

When using double word [unsigned]/bit string [32 bits], double word [signed], double-precision real number data types in structures, make sure that even number devices are used in all members that use those data types. Depending on the member contents, a member may have to be added for adjusting to even numbers. (Example)

Label name	Data type
dLabel1	Double word [signed]
dLabel2	Double word [signed]
wLabel1	Word [signed]
wDummy1	Word [signed]
dLabel3	Double word [signed]
dLabel4	Double word [signed]

← Adjusting member

Precautions

Restrictions on naming labels

The following restrictions apply when naming labels.

- Start the name with a character. Numbers or an underline (_) cannot be used at the beginning of label names.
- Reserved words cannot be used.

For details on the reserved words, refer to the following.

 [Help of MT Developer2](#)

4.5 Binary Operations

Substitution: =

Format	Number of basic steps	Usable steps	
		F/FS	G
(D)=(S)	8	<input type="radio"/>	<input type="radio"/>

Setting data

■ Usable data

: Usable

Setting data	Usable Data									
	Bit device	Word device			Constant			Calculation expression	Bit conditional expression	Comparison conditional expression
		16-bit integer type	32-bit integer type (L)	64-bit floating point type (F)	16-bit integer type (K/H)	32-bit integer type (K/H, L)	64-bit floating point type (K)			
(S)	—	<input type="radio"/>	<input type="radio"/>	<input type="radio"/>	<input type="radio"/>	<input type="radio"/>	<input type="radio"/>	<input type="radio"/>	—	—
(D)	—	<input type="radio"/>	<input type="radio"/>	<input type="radio"/>	—	—	—	—	—	—

■ Description, data type of result

Setting data	Description	Data type of result
(S)	Word device/constant/calculation expression to be substituted	Data type of (D)
(D)	Word device which will store the operation result	

Processing details

- The data value specified with (S) is substituted to the specified word device at (D).
- When (S) and (D) differ in data type, the data at (S) is converted into the data type of (D) and the resultant data is substituted. (When (D) is a 16- or 32-bit integer type and (S) is a 64-bit floating-point type, the fraction part of (S) is discarded.)

Operation error

An operation error will occur if:

- The data at (S) is outside the data type range of (D).
- (D) or (S) is an indirectly specified device and its device No. is outside the range.

Program example

■ Program which substitutes the D0 value to #0

#0 = D0

#0 ← D0

■ Program which substitutes K123456.789 to D0L

D0L = K123456.789

D0L ←

The 64-bit floating-point type is converted into the 32-bit integer type and the result is substituted.

■ Program which substitutes the result of adding K123 and #0 to W0

W0 = K123 + #0

W0 ←
+
#0

Addition: +

Format	Number of basic steps	Usable steps	
		F/FS	G
(S1)+(S2)	7	○	○

Setting data

Usable data

○: Usable

Setting data	Usable Data									
	Bit device	Word device			Constant			Calculation expression	Bit conditional expression	Comparison conditional expression
		16-bit integer type	32-bit integer type (L)	64-bit floating point type (F)	16-bit integer type (K/H)	32-bit integer type (K/H, L)	64-bit floating point type (K)			
(S1)	—	○	○	○	○	○	○	○	—	—
(S2)	—	○	○	○	○	○	○	○	—	—

Description, data type of result

Setting data	Description	Data type of result
(S1)	Augend data	Data type of (S1) or (S2) which is greater
(S2)	Addend data	

Processing details

- The data specified with (S2) is added to the data specified with (S1).
- When (S1) and (S2) differ in data type, the data of the smaller data type is converted into that of the greater type before operation is performed.

Operation error

An operation error will occur if:

- (S1) or (S2) is an indirectly specified device and its device No. is outside the range.

Program example

Program which substitutes the result of adding K123 and #0 to W0

W0 = K123 + #0



Program which substitutes the result of adding #0F and #10 to D0L

D0L = #0F + #10

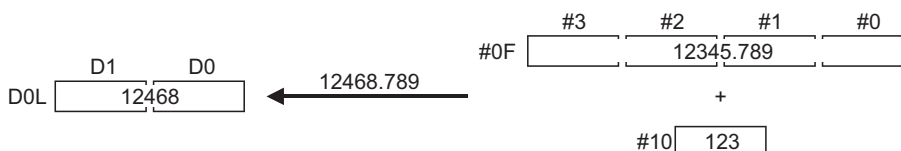

The 64-bit floating-point type data are used for addition, and the result is converted into the 32-bit integer type and then substituted.

Subtraction: -

Format	Number of basic steps	Usable steps	
		F/FS	G
(S1)-(S2)	7	○	○

Setting data

Usable data

○: Usable

Setting data	Usable Data									
	Bit device	Word device			Constant			Calculation expression	Bit conditional expression	Comparison conditional expression
		16-bit integer type	32-bit integer type (L)	64-bit floating point type (F)	16-bit integer type (K/H)	32-bit integer type (K/H, L)	64-bit floating point type (K)			
(S1)	—	○	○	○	○	○	○	—	—	
(S2)	—	○	○	○	○	○	○	—	—	

Description, data type of result

Setting data	Description	Data type of result
(S1)	Minuend data	Data type of (S1) or (S2) which is greater
(S2)	Subtracted data	

Processing details

- The data specified with (S2) is subtracted from the data specified with (S1).
- When (S1) and (S2) differ in data type, the data of the smaller data type is converted into that of the greater type before operation is performed.

Operation error

An operation error will occur if:

- (S1) or (S2) is an indirectly specified device and its device No. is outside the range.

Program example

Program which substitutes the result of subtracting #0 from K123 to W0

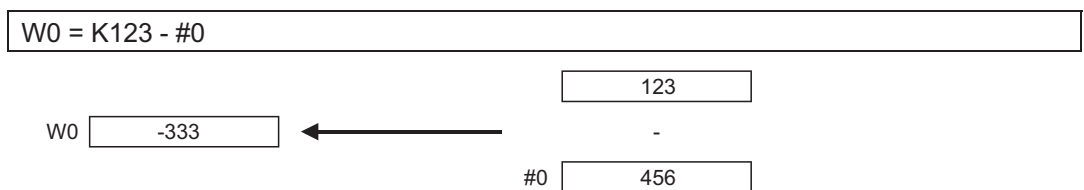

Program which substitutes the result of subtracting #10 from #0F to D0L

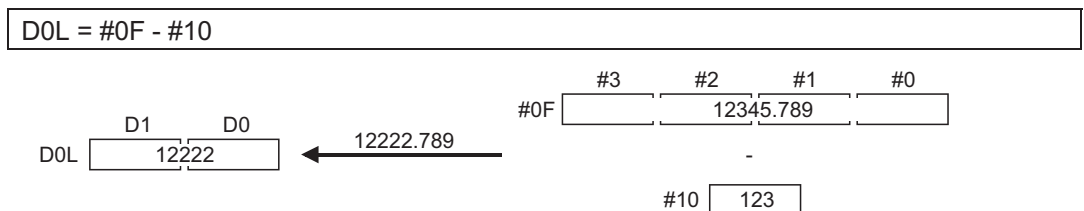

The 64-bit floating-point type data are used for subtraction, and the result is converted into the 32-bit integer type and then substituted.

Multiplication: *

Format	Number of basic steps	Usable steps	
		F/FS	G
(S1)*(S2)	7	<input type="radio"/>	<input type="radio"/>

Setting data

Usable data

: Usable

Setting data	Usable Data									
	Bit device	Word device			Constant			Calculation expression	Bit conditional expression	Comparison conditional expression
		16-bit integer type	32-bit integer type (L)	64-bit floating point type (F)	16-bit integer type (K/H)	32-bit integer type (K/H, L)	64-bit floating point type (K)			
(S1)	—	<input type="radio"/>	<input type="radio"/>	<input type="radio"/>	<input type="radio"/>	<input type="radio"/>	<input type="radio"/>	<input type="radio"/>	—	—
(S2)	—	<input type="radio"/>	<input type="radio"/>	<input type="radio"/>	<input type="radio"/>	<input type="radio"/>	<input type="radio"/>	<input type="radio"/>	—	—

Description, data type of result

Setting data	Description	Data type of result
(S1)	Multiplicand data	Data type of (S1) or (S2) which is greater
(S2)	Multiplier data	

Processing details

- The data specified with (S1) is multiplied by the data specified with (S2).
- When (S1) and (S2) differ in data type, the data of the smaller data type is converted into that of the greater type before operation is performed.

Operation error

An operation error will occur if:

- (S1) or (S2) is an indirectly specified device and its device No. is outside the range.

Program example

Program which substitutes the result of multiplying K123 by #0 to W0

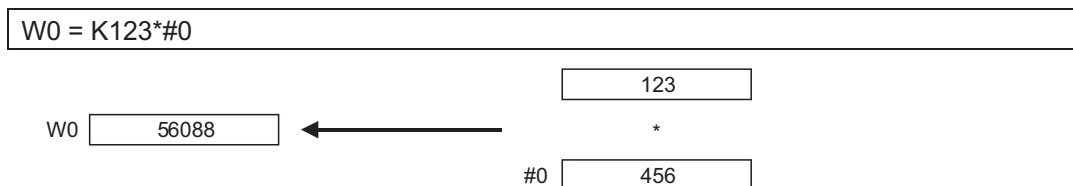

Program which substitutes the result of multiplying #0F by #10 to D0L

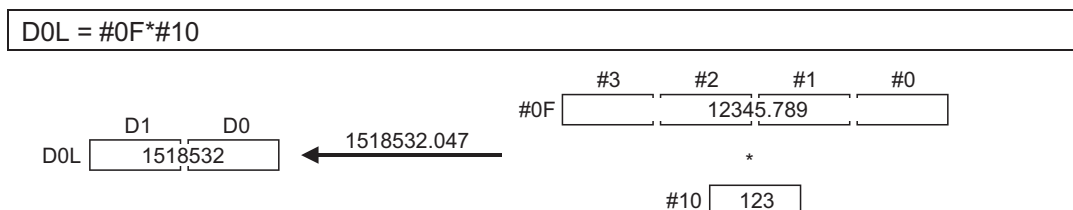

The 64-bit floating-point type data are used for multiplication, and the result is converted into the 32-bit integer type and then substituted.

Division: /

Format	Number of basic steps	Usable steps	
		F/FS	G
(S1)/(S2)	7	○	○

Setting data

■ Usable data

○: Usable

Setting data	Usable Data									
	Bit device	Word device			Constant			Calculation expression	Bit conditional expression	Comparison conditional expression
		16-bit integer type	32-bit integer type (L)	64-bit floating point type (F)	16-bit integer type (K/H)	32-bit integer type (K/H, L)	64-bit floating point type (K)			
(S1)	—	○	○	○	○	○	○	○	—	—
(S2)	—	○	○	○	○	○	○	○	—	—

■ Description, data type of result

Setting data	Description	Data type of result
(S1)	Dividend data	Data type of (S1) or (S2) which is greater
(S2)	Divisor data	

Processing details

- The data specified with (S1) is divided by the data specified with (S2) to find a quotient.
- When (S1) and (S2) differ in data type, the data of the smaller data type is converted into that of the greater type before operation is performed.

Operation error

An operation error will occur if:

- (S2) is 0.
- (S1) or (S2) is an indirectly specified device and its device No. is outside the range.

Program example

■ Program which divides K456 by #0 and substitutes a quotient to W0

```
W0 = K456 / #0
```



■ Program which divides #0F by #10 and substitutes a quotient to D0L

```
D0L = #0F / #10
```



The 64-bit floating-point type data are used for division, and the quotient is converted into the 32-bit integer type and then substituted.

Remainder: %

Format	Number of basic steps	Usable steps	
		F/FS	G
(S1)%(S2)	7	○	○

Setting data

■ Usable data

○: Usable

Setting data	Usable Data									
	Bit device	Word device			Constant			Calculation expression	Bit conditional expression	Comparison conditional expression
		16-bit integer type	32-bit integer type (L)	64-bit floating point type (F)	16-bit integer type (K/H)	32-bit integer type (K/H, L)	64-bit floating point type (K)			
(S1)	—	○	○	○	○	○	○	○	—	—
(S2)	—	○	○	○	○	○	○	○	—	—

■ Description, data type of result

Setting data	Description	Data type of result
(S1)	Dividend data	Data type (integer type) of (S1) or (S2) which is greater (Integer type)
(S2)	Divisor data	

Processing details

- The data specified with (S1) is divided by the data specified with (S2) to find a remainder.
- When (S1) and (S2) differ in data type, the data of the smaller data type is converted into that of the greater type before operation is performed.

Operation error

An operation error will occur if:

- (S2) is 0.
- (S1) or (S2) is an indirectly specified device and its device No. is outside the range.

Program example

■ Program which divides K456 by #0 and substitutes a remainder to W0

```
W0 = K456 % #0
```



4.6 Bit Operations

Bit inversion (Complement): ~

Format	Number of basic steps	Usable steps	
		F/FS	G
~(S)	4	○	○

Setting data

■ Usable data

○: Usable

Setting data	Usable Data									
	Bit device	Word device			Constant			Calculation expression	Bit conditional expression	Comparison conditional expression
		16-bit integer type	32-bit integer type (L)	64-bit floating point type (F)	16-bit integer type (K/H)	32-bit integer type (K/H, L)	64-bit floating point type (K)			
(S)	—	○	○	—	○	○	—	○	—	—

■ Description, data type of result

Setting data	Description	Data type of result
(S)	Data whose bits will be inverted	Data type of (S) (Integer type)

Processing details

The bit inverted value of the data specified with (S) is found.

Operation error

An operation error will occur if:

- (S) is an indirectly specified device and its device No. is outside the range.

Program example

■ Program which finds the bit inverted value of #0 and substitutes the value to D0

```
D0 = ~#0
```



Bit logical AND: &

Format	Number of basic steps	Usable steps	
		F/FS	G
(S1)&(S2)	7	○	○

Setting data

Usable data

○: Usable

Setting data	Usable Data									
	Bit device	Word device			Constant			Calculation expression	Bit conditional expression	Comparison conditional expression
		16-bit integer type	32-bit integer type (L)	64-bit floating point type (F)	16-bit integer type (K/H)	32-bit integer type (K/H, L)	64-bit floating point type (K)			
(S1)	—	○	○	—	○	○	—	○	—	—
(S2)	—	○	○	—	○	○	—	○	—	—

Description, data type of result

Setting data	Description	Data type of result
(S1)	Data which will be ANDed bit-by-bit	Data type of (S1) or (S2) which is greater (Integer type)
(S2)		

Processing details

- The bit-by-bit logical product of the data specified with (S1) and the data specified with (S2) is found.
- When (S1) and (S2) differ in data type, the data of the smaller data type is converted into that of the greater type before operation is performed. At this time, note that signed data is converted.

Operation error

An operation error will occur if:

- (S1) or (S2) is an indirectly specified device and its device No. is outside the range.

Program example

Program which ANDs #0 and #1 and substitutes the result to D0

```
D0 = #0 & #1
```

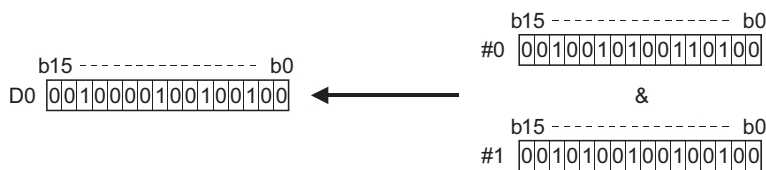

Bit logical OR: |

Format	Number of basic steps	Usable steps	
		F/FS	G
(S1) (S2)	7	○	○

Setting data

Usable data

○: Usable

Setting data	Usable Data									
	Bit device	Word device			Constant			Calculation expression	Bit conditional expression	Comparison conditional expression
		16-bit integer type	32-bit integer type (L)	64-bit floating point type (F)	16-bit integer type (K/H)	32-bit integer type (K/H, L)	64-bit floating point type (K)			
(S1)	—	○	○	—	○	○	—	○	—	—
(S2)	—	○	○	—	○	○	—	○	—	—

Description, data type of result

Setting data	Description	Data type of result
(S1)	Data which will be ORed bit-by-bit	Data type of (S1) or (S2) which is greater (Integer type)
(S2)		

Processing details

- The bit-by-bit logical add of the data specified with (S1) and the data specified with (S2) is found.
- When (S1) and (S2) differ in data type, the data of the smaller data type is converted into that of the greater type before operation is performed. At this time, note that signed data is converted.

Operation error

An operation error will occur if:

- (S1) or (S2) is an indirectly specified device and its device No. is outside the range.

Program example

Program which ORs #0 and #1 and substitutes the result to D0

```
D0 = #0 | #1
```

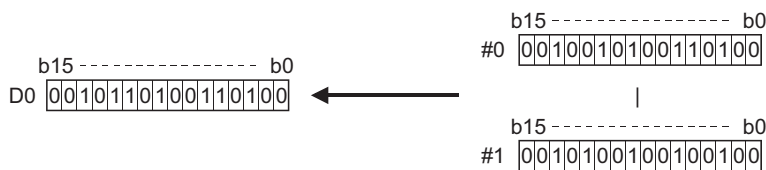

Bit exclusive logical OR: ^

Format	Number of basic steps	Usable steps	
		F/FS	G
(S1)^(S2)	7	○	○

Setting data

Usable data

○: Usable

Setting data	Usable Data									
	Bit device	Word device			Constant			Calculation expression	Bit conditional expression	Comparison conditional expression
		16-bit integer type	32-bit integer type (L)	64-bit floating point type (F)	16-bit integer type (K/H)	32-bit integer type (K/H, L)	64-bit floating point type (K)			
(S1)	—	○	○	—	○	○	—	○	—	—
(S2)	—	○	○	—	○	○	—	○	—	—

Description, data type of result

Setting data	Description	Data type of result
(S1)	Data which will be EXCLUSIVE ORed bit-by-bit	Data type of (S1) or (S2) which is greater (Integer type)
(S2)		

Processing details

- The bit-by-bit exclusive logical add of the data specified with (S1) and the data specified with (S2) is found.
- When (S1) and (S2) differ in data type, the data of the smaller data type is converted into that of the greater type before operation is performed. At this time, note that signed data is converted.

Operation error

An operation error will occur if:

- (S1) or (S2) is an indirectly specified device and its device No. is outside the range.

Program example

Program which EXCLUSIVE ORs #0 and #1 and substitutes the result to D0

```
D0 = #0 ^ #1
```

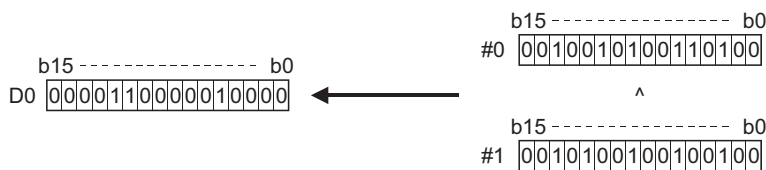

Bit right shift: >>

Format	Number of basic steps	Usable steps	
		F/FS	G
(S1) >> (S2)	7	○	○

Setting data

■ Usable data

○: Usable

Setting data	Usable Data									
	Bit device	Word device			Constant			Calculation expression	Bit conditional expression	Comparison conditional expression
		16-bit integer type	32-bit integer type (L)	64-bit floating point type (F)	16-bit integer type (K/H)	32-bit integer type (K/H, L)	64-bit floating point type (K)			
(S1)	—	○	○	—	○	○	—	○	—	—
(S2)	—	○	○	—	○	○	—	○	—	—

■ Description, data type of result

Setting data	Description	Data type of result
(S1)	Data to be right-shifted	Data type of (S1) (Integer type)
(S2)	Number of right shifts	

Processing details

- The data specified with (S1) is shifted to the right by the number of times specified with (S2).
- If the most significant bit of (S1) is 1, 1 enters the most significant bit of the right shift result. If the most significant bit of (S1) is 0, 0 enters the most significant bit of the right shift result.
- When (S1) is a 16-bit integer type and (S2) is a negative number or not less than 16, the result is 0.
- When (S1) is a 32-bit integer type and (S2) is a negative number or not less than 32, the result is 0.

Operation error

An operation error will occur if:

- (S1) or (S2) is an indirectly specified device and its device No. is outside the range.

Program example

■ Program which shifts #0 two bit positions to the right and substitutes the result to D0

```
D0 = #0 >> K2
```



Bit left shift: <<

Format	Number of basic steps	Usable steps	
		F/FS	G
(S1) << (S2)	7	○	○

Setting data

■ Usable data

○: Usable

Setting data	Usable Data									
	Bit device	Word device			Constant			Calculation expression	Bit conditional expression	Comparison conditional expression
		16-bit integer type	32-bit integer type (L)	64-bit floating point type (F)	16-bit integer type (K/H)	32-bit integer type (K/H, L)	64-bit floating point type (K)			
(S1)	—	○	○	—	○	○	—	○	—	—
(S2)	—	○	○	—	○	○	—	○	—	—

■ Description, data type of result

Setting data	Description	Data type of result
(S1)	Data to be left-shifted	Data type of (S1) (Integer type)
(S2)	Number of left shifts	

Processing details

- The data specified with (S1) is shifted to the left by the number of times specified with (S2).
- 0 enters the least significant bit of the left shift result.
- When (S1) is a 16-bit integer type and (S2) is a negative number or not less than 16, the result is 0.
- When (S1) is a 32-bit integer type and (S2) is a negative number or not less than 32, the result is 0.

Operation error

An operation error will occur if:

- (S1) or (S2) is an indirectly specified device and its device No. is outside the range.

Program example

■ Program which shifts #0 one bit position to the left and substitutes the result to D0

```
D0 = #0 << K1
```



Sign inversion (Complement of 2): -

Format	Number of basic steps	Usable steps	
		F/FS	G
-(S)	4	○	○

Setting data

■ Usable data

○: Usable

Setting data	Usable Data									
	Bit device	Word device			Constant			Calculation expression	Bit conditional expression	Comparison conditional expression
		16-bit integer type	32-bit integer type (L)	64-bit floating point type (F)	16-bit integer type (K/H)	32-bit integer type (K/H, L)	64-bit floating point type (K)			
(S)	—	○	○	○	○	○	○	○	—	—

■ Description, data type of result

Setting data	Description	Data type of result
(S)	Data whose sign will be inverted	Data type of (S)

Processing details

The sign-inverted value of the data specified with (S) is found.

Operation error

An operation error will occur if:

- (S) is an indirectly specified device and its device No. is outside the range.

Program example

■ Program which substitutes the sign-inverted value of #0 to D0

```
D0 = - #0
```



4.7 Standard Functions

Sine: SIN

Format	Number of basic steps	Usable steps	
		F/FS	G
SIN(S)	4	<input type="radio"/>	<input type="radio"/>

Setting data

■ Usable data

○: Usable

Setting data	Usable Data									
	Bit device	Word device			Constant			Calculation expression	Bit conditional expression	Comparison conditional expression
		16-bit integer type	32-bit integer type (L)	64-bit floating point type (F)	16-bit integer type (K/H)	32-bit integer type (K/H, L)	64-bit floating point type (K)			
(S)	—	<input type="radio"/>	<input type="radio"/>	<input type="radio"/>	<input type="radio"/>	<input type="radio"/>	<input type="radio"/>	<input type="radio"/>	—	—

■ Description, data type of result

Setting data	Description	Data type of result
(S)	Angle data on which SIN (sine) operation will be performed	Floating-point type

Processing details

- SIN (sine) operation is performed on the data specified with (S).
- The data specified with (S) is in an angle (degree) unit.
- If (S) is an integer type, it is converted into a floating-point type before operation is performed.

Operation error

An operation error will occur if:

- (S) is an indirectly specified device and its device No. is outside the range.

Program example

■ Program which performs the SIN operation of D0 and substitutes the result to #0F

```
#0F = SIN(D0)
```



Cosine: COS

Format	Number of basic steps	Usable steps	
		F/FS	G
COS(S)	4	○	○

Setting data

Usable data

○: Usable

Setting data	Usable Data									
	Bit device	Word device			Constant			Calculation expression	Bit conditional expression	Comparison conditional expression
		16-bit integer type	32-bit integer type (L)	64-bit floating point type (F)	16-bit integer type (K/H)	32-bit integer type (K/H, L)	64-bit floating point type (K)			
(S)	—	○	○	○	○	○	○	○	—	—

Description, data type of result

Setting data	Description	Data type of result
(S)	Angle data on which COS (cosine) operation will be performed	Floating-point type

Processing details

- COS (cosine) operation is performed on the data specified with (S).
- The data specified with (S) is in an angle (degree) unit.
- If (S) is an integer type, it is converted into a floating-point type before operation is performed.

Operation error

An operation error will occur if:

- (S) is an indirectly specified device and its device No. is outside the range.

Program example

Program which performs the COS operation of D0 and substitutes the result to #0F

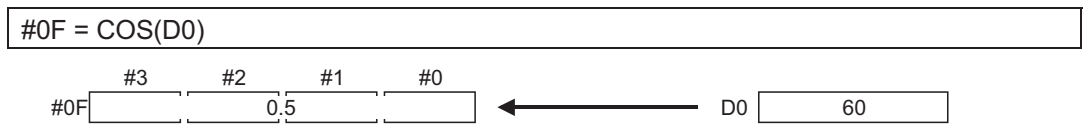

Tangent: TAN

Format	Number of basic steps	Usable steps	
		F/FS	G
TAN(S)	4	<input type="radio"/>	<input type="radio"/>

Setting data

Usable data

: Usable

Setting data	Usable Data									
	Bit device	Word device			Constant			Calculation expression	Bit conditional expression	Comparison conditional expression
		16-bit integer type	32-bit integer type (L)	64-bit floating point type (F)	16-bit integer type (K/H)	32-bit integer type (K/H, L)	64-bit floating point type (K)			
(S)	—	<input type="radio"/>	<input type="radio"/>	<input type="radio"/>	<input type="radio"/>	<input type="radio"/>	<input type="radio"/>	<input type="radio"/>	—	—

Description, data type of result

Setting data	Description	Data type of result
(S)	Angle data on which TAN (tangent) operation will be performed	Floating-point type

Processing details

- TAN (tangent) operation is performed on the data specified with (S).
- The data specified with (S) is in an angle (degree) unit.
- If (S) is an integer type, it is converted into a floating-point type before operation is performed.

Operation error

An operation error will occur if:

- (S) is an indirectly specified device and its device No. is outside the range.
- (S) is $90 + (180 \cdot n)$. ("n" is an integer)

Program example

Program which performs the TAN operation of D0 and substitutes the result to #0F

```
#0F = TAN(D0)
```



Arcsine: ASIN

Format	Number of basic steps	Usable steps	
		F/FS	G
ASIN(S)	4	○	○

Setting data

Usable data

○: Usable

Setting data	Usable Data									
	Bit device	Word device			Constant			Calculation expression	Bit conditional expression	Comparison conditional expression
		16-bit integer type	32-bit integer type (L)	64-bit floating point type (F)	16-bit integer type (K/H)	32-bit integer type (K/H, L)	64-bit floating point type (K)			
(S)	—	○	○	○	○	○	○	○	—	—

Description, data type of result

Setting data	Description	Data type of result
(S)	SIN value data on which SIN^{-1} (arcsine) operation will be performed	Floating-point type

Processing details

- SIN^{-1} (arcsine) operation is performed on the SIN value data specified with (S) to find an angle.
- The SIN value specified with (S) must be within the range -1.0 to 1.0.
- The operation result is in an angle (degree) unit.
- If (S) is an integer type, it is converted into a floating-point type before operation is performed.

Operation error

An operation error will occur if:

- (S) is outside the range -1.0 to 1.0.
- (S) is an indirectly specified device and its device number is outside the range.

Program example

Program which performs the SIN^{-1} (arcsine) operation of D0 and substitutes the result to #0F

```
#0F = ASIN(D0)
```



Arccosine: ACOS

Format	Number of basic steps	Usable steps	
		F/FS	G
ACOS(S)	4	<input type="radio"/>	<input type="radio"/>

Setting data

Usable data

○: Usable

Setting data	Usable Data									
	Bit device	Word device			Constant			Calculation expression	Bit conditional expression	Comparison conditional expression
		16-bit integer type	32-bit integer type (L)	64-bit floating point type (F)	16-bit integer type (K/H)	32-bit integer type (K/H, L)	64-bit floating point type (K)			
(S)	—	<input type="radio"/>	<input type="radio"/>	<input type="radio"/>	<input type="radio"/>	<input type="radio"/>	<input type="radio"/>	<input type="radio"/>	—	—

Description, data type of result

Setting data	Description	Data type of result
(S)	COS value data on which COS^{-1} (arccosine) operation will be performed	Floating-point type

Processing details

- COS^{-1} (arccosine) operation is performed on the COS value data specified with (S) to find an angle.
- The COS value specified with (S) must be within the range -1.0 to 1.0.
- The operation result is in an angle (degree) unit.
- If (S) is an integer type, it is converted into a floating-point type before operation is performed.

Operation error

An operation error will occur if:

- (S) is outside the range -1.0 to 1.0.
- (S) is an indirectly specified device and its device No. is outside the range.

Program example

Program which performs the COS^{-1} (arccosine) operation of D0F and substitutes the result to #0F

```
#0F = ACOS(D0F)
```



Arctangent: ATAN

Format	Number of basic steps	Usable steps	
		F/FS	G
ATAN(S)	4	<input type="radio"/>	<input type="radio"/>

Setting data

Usable data

: Usable

Setting data	Usable Data									
	Bit device	Word device			Constant			Calculation expression	Bit conditional expression	Comparison conditional expression
		16-bit integer type	32-bit integer type (L)	64-bit floating point type (F)	16-bit integer type (K/H)	32-bit integer type (K/H, L)	64-bit floating point type (K)			
(S)	—	<input type="radio"/>	<input type="radio"/>	<input type="radio"/>	<input type="radio"/>	<input type="radio"/>	<input type="radio"/>	<input type="radio"/>	—	—

Description, data type of result

Setting data	Description	Data type of result
(S)	TAN value data on which TAN^{-1} (arctangent) operation will be performed	Floating-point type

Processing details

- TAN^{-1} (arctangent) operation is performed on the TAN value data specified with (S) to find an angle.
- The operation result is in an angle (degree) unit.
- If (S) is an integer type, it is converted into a floating-point type before operation is performed.

Operation error

An operation error will occur if:

- (S) is an indirectly specified device and its device No. is outside the range.

Program example

Program which performs the TAN^{-1} (arctangent) operation of D0F and substitutes the result to #0F

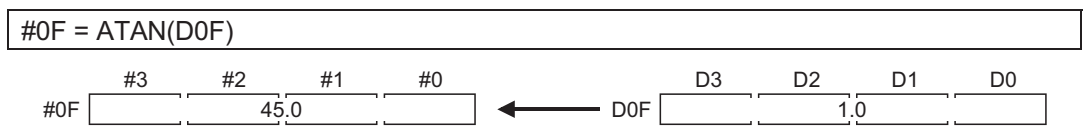

Square root: SQRT

Format	Number of basic steps	Usable steps	
		F/FS	G
SQRT(S)	4	○	○

Setting data

Usable data

○: Usable

Setting data	Usable Data									
	Bit device	Word device			Constant			Calculation expression	Bit conditional expression	Comparison conditional expression
		16-bit integer type	32-bit integer type (L)	64-bit floating point type (F)	16-bit integer type (K/H)	32-bit integer type (K/H, L)	64-bit floating point type (K)			
(S)	—	○	○	○	○	○	○	○	—	—

Description, data type of result

Setting data	Description	Data type of result
(S)	Data on which square root operation will be performed	Floating-point type

Processing details

- The square root of the data specified with (S) is found.
- Only a positive number may be specified with (S). (Operation cannot be performed with a negative number.)
- If (S) is an integer type, it is converted into a floating-point type before operation is performed.

Operation error

An operation error will occur if:

- (S) is a negative number.
- (S) is an indirectly specified device and its device No. is outside the range.

Program example

Program which finds the square root of D0F and substitutes the result to #0F

```
#0F = SQRT(D0F)
```



Natural logarithm: LN

Format	Number of basic steps	Usable steps	
		F/FS	G
LN(S)	4	<input type="radio"/>	<input type="radio"/>

Setting data

Usable data

: Usable

Setting data	Usable Data									
	Bit device	Word device			Constant			Calculation expression	Bit conditional expression	Comparison conditional expression
		16-bit integer type	32-bit integer type (L)	64-bit floating point type (F)	16-bit integer type (K/H)	32-bit integer type (K/H, L)	64-bit floating point type (K)			
(S)	—	<input type="radio"/>	<input type="radio"/>	<input type="radio"/>	<input type="radio"/>	<input type="radio"/>	<input type="radio"/>	<input type="radio"/>	—	—

Description, data type of result

Setting data	Description	Data type of result
(S)	Data on which natural logarithm operation will be performed	Floating-point type

Processing details

- The base e natural logarithm of the data specified with (S) is found.
- Only a positive number may be specified with (S). (Operation cannot be performed with a negative number.)
- If (S) is an integer type, it is converted into a floating-point type before operation is performed.

Operation error

An operation error will occur if:

- (S) is 0 or a negative number.
- (S) is an indirectly specified device and its device No. is outside the range.

Program example

Program which finds the natural logarithm of D0F and substitutes the result to #0F

```
#0F = LN(D0F)
```



Exponential operation: EXP

Format	Number of basic steps	Usable steps	
		F/FS	G
EXP(S)	4	○	○

Setting data

Usable data

○: Usable

Setting data	Usable Data									
	Bit device	Word device			Constant			Calculation expression	Bit conditional expression	Comparison conditional expression
		16-bit integer type	32-bit integer type (L)	64-bit floating point type (F)	16-bit integer type (K/H)	32-bit integer type (K/H, L)	64-bit floating point type (K)			
(S)	—	○	○	○	○	○	○	○	—	—

Description, data type of result

Setting data	Description	Data type of result
(S)	Data on which exponential operation will be performed	Floating-point type

Processing details

- Exponential operation is performed on the base e data specified with (S).
- If (S) is an integer type, it is converted into a floating-point type before operation is performed.

Operation error

An operation error will occur if:

- (S) is an indirectly specified device and its device No. is outside the range.

Program example

Program which performs exponential operation of D0F and substitutes the result to #0F



Absolute value: ABS

Format	Number of basic steps	Usable steps	
		F/FS	G
ABS(S)	4	○	○

Setting data

Usable data

○: Usable

Setting data	Usable Data									
	Bit device	Word device			Constant			Calculation expression	Bit conditional expression	Comparison conditional expression
		16-bit integer type	32-bit integer type (L)	64-bit floating point type (F)	16-bit integer type (K/H)	32-bit integer type (K/H, L)	64-bit floating point type (K)			
(S)	—	○	○	○	○	○	○	○	—	—

Description, data type of result

Setting data	Description	Data type of result
(S)	Data on which absolute value conversion will be performed	Data type of (S)

Processing details

The absolute value of the data specified with (S) is found.

Operation error

An operation error will occur if:

- (S) is 16-bit integer type and other than -32767 to 32767.
- (S) is 32-bit integer type and other than -2147483647 to 2147483647.
- (S) is an indirectly specified device and its device No. is outside the range.

Program example

Program which finds the absolute value of D0F and substitutes the result to #0F

```
#0F = ABS(D0F)
```



Round-off: RND

Format	Number of basic steps	Usable steps	
		F/FS	G
RND(S)	4	<input type="radio"/>	<input type="radio"/>

Setting data

Usable data

: Usable

Setting data	Usable Data									
	Bit device	Word device			Constant			Calculation expression	Bit conditional expression	Comparison conditional expression
		16-bit integer type	32-bit integer type (L)	64-bit floating point type (F)	16-bit integer type (K/H)	32-bit integer type (K/H, L)	64-bit floating point type (K)			
(S)	—	<input type="radio"/>	<input type="radio"/>	<input type="radio"/>	<input type="radio"/>	<input type="radio"/>	<input type="radio"/>	<input type="radio"/>	—	—

Description, data type of result

Setting data	Description	Data type of result
(S)	Data whose fractional portion will be rounded off	Data type of (S)

Processing details

- The rounded-off fractional portion value of the data specified with (S) is found.
- If (S) is a negative number, the absolute value of (S) is found and its fractional portion is rounded off and signed.
- If (S) is an integer type, its value is returned unchanged, with no conversion processing performed.

Operation error

An operation error will occur if:

- (S) is an indirectly specified device and its device No. is outside the range.

Program example

Program which finds the rounded-off fractional portion value of D0F and substitutes the result to #0F

```
#0F = RND(D0F)
```



Program which finds the rounded-off fractional portion value of D4F and substitutes the result to #0F (when D4F is a negative number)

```
#0F = RND(D4F)
```



Round-down: FIX

Format	Number of basic steps	Usable steps	
		F/FS	G
FIX(S)	4	<input type="radio"/>	<input type="radio"/>

Setting data

Usable data

: Usable

Setting data	Usable Data									
	Bit device	Word device			Constant			Calculation expression	Bit conditional expression	Comparison conditional expression
		16-bit integer type	32-bit integer type (L)	64-bit floating point type (F)	16-bit integer type (K/H)	32-bit integer type (K/H, L)	64-bit floating point type (K)			
(S)	—	<input type="radio"/>	<input type="radio"/>	<input type="radio"/>	<input type="radio"/>	<input type="radio"/>	<input type="radio"/>	<input type="radio"/>	—	—

Description, data type of result

Setting data	Description	Data type of result
(S)	Data whose fractional portion will be rounded down	Data type of (S)

Processing details

- The largest integer not greater than the data specified with (S) is found.
- If the (S) value is positive, the absolute value will be smaller, and if it is negative, the absolute value will be greater.
- If (S) is an integer type, its value is returned unchanged, with no conversion processing performed.

Operation error

An operation error will occur if:

- (S) is an indirectly specified device and its device No. is outside the range.

Program example

Program which finds the rounded-down fractional portion value of D0F and substitutes the result to #0F

```
#0F = FIX(D0F)
```



Program which finds the rounded-down fractional portion value of D4F and substitutes the result to #0F (when D4F is a negative number)

```
#0F = FIX(D4F)
```



Round-up: FUP

Format	Number of basic steps	Usable steps	
		F/FS	G
FUP(S)	4	<input type="radio"/>	<input type="radio"/>

Setting data

Usable data

○: Usable

Setting data	Usable Data									
	Bit device	Word device			Constant			Calculation expression	Bit conditional expression	Comparison conditional expression
		16-bit integer type	32-bit integer type (L)	64-bit floating point type (F)	16-bit integer type (K/H)	32-bit integer type (K/H, L)	64-bit floating point type (K)			
(S)	—	<input type="radio"/>	<input type="radio"/>	<input type="radio"/>	<input type="radio"/>	<input type="radio"/>	<input type="radio"/>	<input type="radio"/>	—	—

Description, data type of result

Setting data	Description	Data type of result
(S)	Data whose fractional portion will be rounded up	Data type of (S)

Processing details

- The smallest integer not less than the data specified with (S) is found.
- If the (S) value is positive, the absolute value will be greater, and if it is negative, the absolute value will be smaller.
- If (S) is an integer type, its value is returned unchanged, with no conversion processing performed.

Operation error

An operation error will occur if:

- (S) is an indirectly specified device and its device No. is outside the range.

Program example

Program which finds the rounded-up fractional portion value of D0F and substitutes the result to #0F

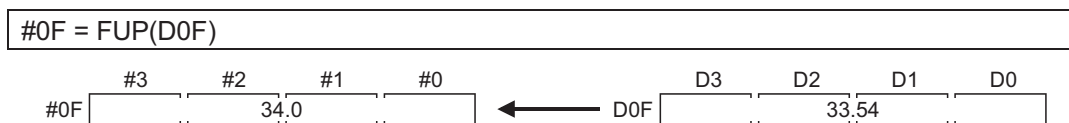

Program which finds the rounded-up fractional portion value of D4F and substitutes the result to #0F (when D4F is a negative number)



BCD -> BIN conversion: BIN

Format	Number of basic steps	Usable steps	
		F/FS	G
BIN(S)	4	○	○

Setting data

Usable data

○: Usable

Setting data	Usable Data									
	Bit device	Word device			Constant			Calculation expression	Bit conditional expression	Comparison conditional expression
		16-bit integer type	32-bit integer type (L)	64-bit floating point type (F)	16-bit integer type (K/H)	32-bit integer type (K/H, L)	64-bit floating point type (K)			
(S)	—	○	○	—	○	○	—	○	—	—

Description, data type of result

Setting data	Description	Data type of result
(S)	BCD data which will be converted into BIN data	Data type of (S) (Integer type)

Processing details

- The BCD data specified with (S) is converted into BIN data.
- If (S) is a 16-bit integer type, the data range is 0 to 9999.
- If (S) is a 32-bit integer type, the data range is 0 to 99999999.

Operation error

An operation error will occur if:

- A value other than 0 to 9 is in any digit of (S).
- (S) is an indirectly specified device and its device No. is outside the range.

Program example

Program which converts the BCD data of D0 into BIN data and substitutes the result to #0

```
#0 = BIN(D0)
```

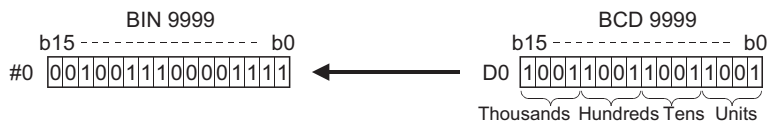

BIN -> BCD conversion: BCD

Format	Number of basic steps	Usable steps	
		F/FS	G
BCD(S)	4	<input type="radio"/>	<input type="radio"/>

Setting data

Usable data

○: Usable

Setting data	Usable Data									
	Bit device	Word device			Constant			Calculation expression	Bit conditional expression	Comparison conditional expression
		16-bit integer type	32-bit integer type (L)	64-bit floating point type (F)	16-bit integer type (K/H)	32-bit integer type (K/H, L)	64-bit floating point type (K)			
(S)	—	<input type="radio"/>	<input type="radio"/>	—	<input type="radio"/>	<input type="radio"/>	—	<input type="radio"/>	—	—

Description, data type of result

Setting data	Description	Data type of result
(S)	BIN data which will be converted into BCD data	Data type of (S) (Integer type)

Processing details

- The BIN data specified with (S) is converted into BCD data.
- If (S) is a 16-bit integer type, the data range is 0 to 9999.
- If (S) is a 32-bit integer type, the data range is 0 to 99999999.

Operation error

An operation error will occur if:

- The data is other than 0 to 9999 when (S) is a 16-bit integer type.
- The data is other than 0 to 99999999 when (S) is a 32-bit integer type.
- (S) is an indirectly specified device and its device No. is outside the range.

Program example

Program which converts the BIN data of D0 into BCD data and substitutes the result to #0

```
#0 = BCD(D0)
```

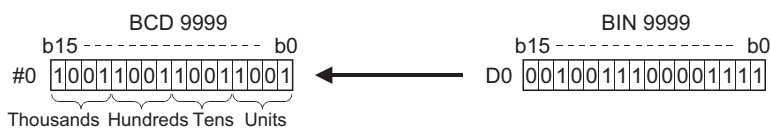

4.8 Data Control

16-bit integer type scaling: SCL

Format	Number of basic steps	Usable steps	
		F/FS	G
SCL(S1), (S2), (S3), (D)	15	○	○

Setting data

■ Usable data

○: Usable

Setting data	Usable Data									
	Bit device	Word device			Constant			Calculation expression	Bit conditional expression	Comparison conditional expression
		16-bit integer type	32-bit integer type (L)	64-bit floating point type (F)	16-bit integer type (K/H)	32-bit integer type (K/H, L)	64-bit floating point type (K)			
(S1)	—	○	—	—	○	—	—	—	—	—
(S2)	—	○	—	—	○	—	—	○	—	—
(S3)	—	○	—	—	—	—	—	—	—	—
(D)	—	○	—	—	—	—	—	—	—	—

■ Description, data type of result

Setting data	Description	Data type of result
(S1)	Data which specifies the search/conversion method 0: Positive conversion by sequential search 1: Inverse conversion by sequential search 2: Positive conversion by binary search 3: Inverse conversion by binary search	—
(S2)	Input value for positive/inverse conversion	
(S3)	Start device No. which stores the scaling conversion data	
(D)	Device No. which stores the conversion result	

Processing details

- 16-bit integer type scaling calculates the output value from the set input value based on the scaling conversion data where a maximum of 4000 points data $((X_0, Y_0) \text{ to } (X_{N-1}, Y_{N-1}))$, N: the number of points) are defined. Set the point data corresponding to the input value in ascending order. (Positive conversion: $X_0 < X_1 < \dots < X_{N-1}$, Inverse conversion: $Y_0 < Y_1 < \dots < Y_{N-1}$)
- The method for output value calculation is either positive conversion (Input value: point X, Output value: point Y) or inverse conversion (Input value: point Y, Output value: point X) and is specified with (S1). Each of the calculation methods is as follows.

■When the input value is between two points of scaling conversion data

The output value is calculated from the nearest two points of the input value.

N: Number of points

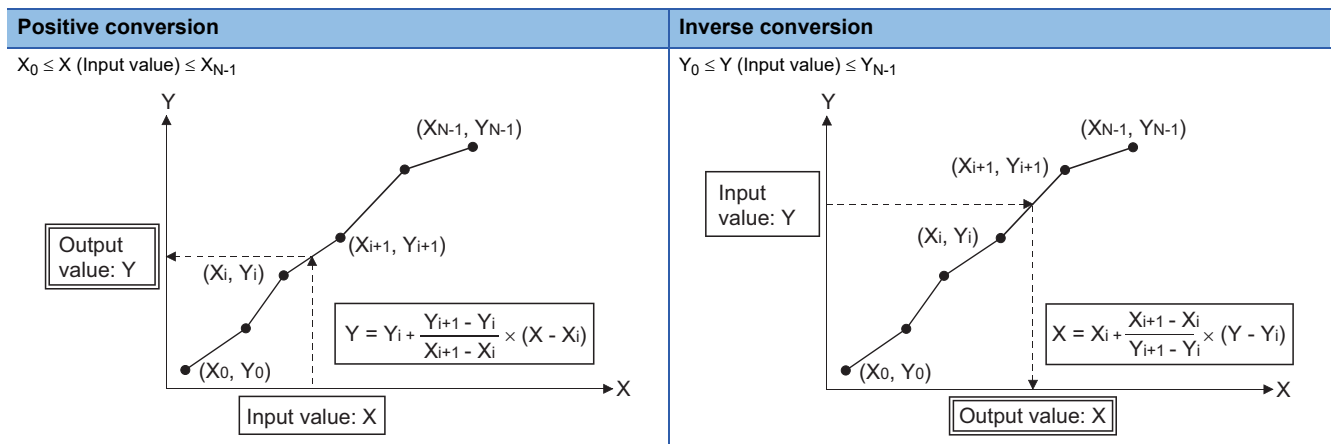

■When the input value is not between two points of scaling conversion data

The output value is calculated from the first or last two points of scaling conversion data.

N: Number of points

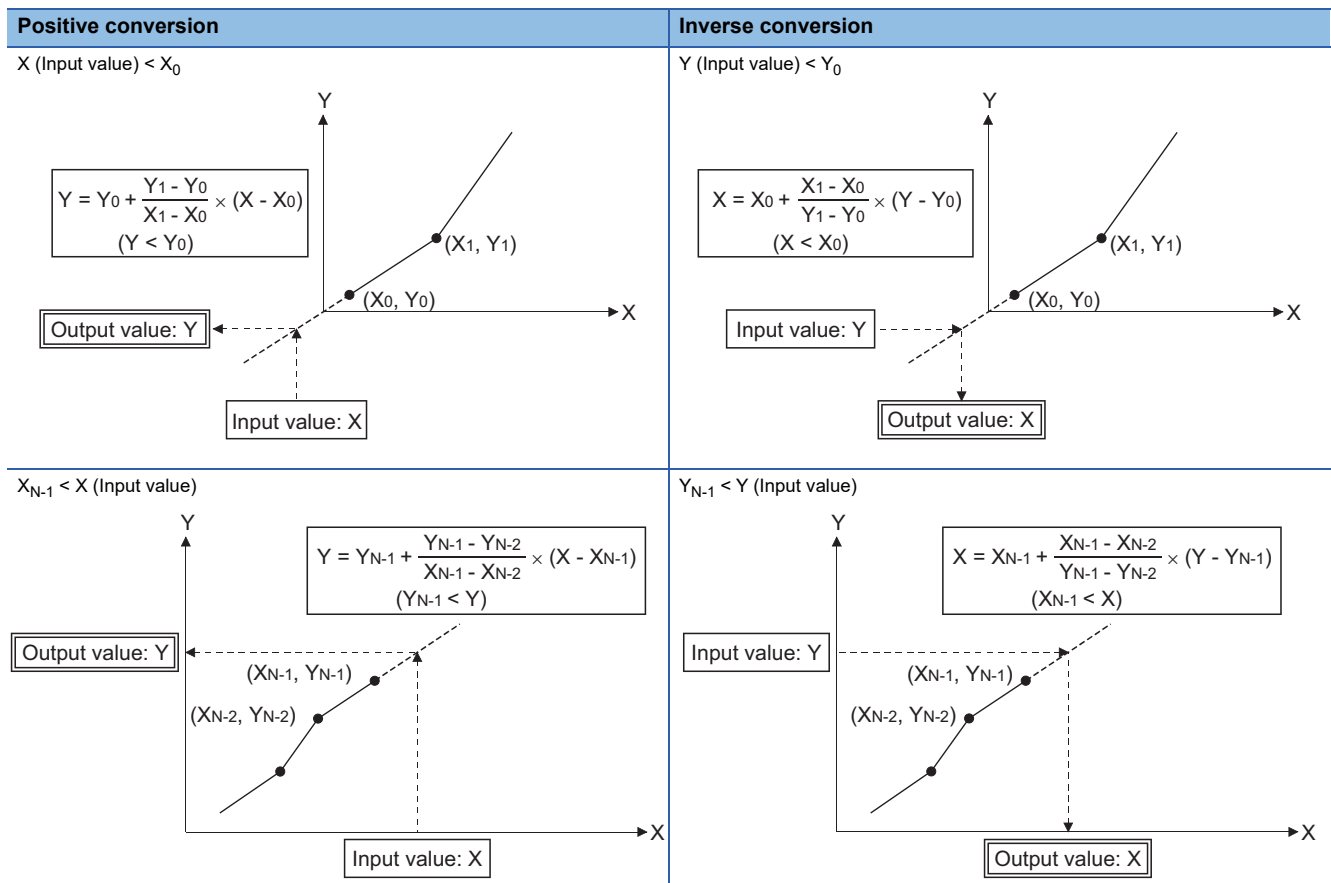

Point

When the input value is outside the range of scaling conversion data or calculation result of output value is outside the range of -32768 to 32767, an operation error will occur.

- Conversion of the input value specified with (S2) is executed according to the search/conversion method specified with (S1), using the scaling conversion data of device (S3) or later. The conversion result is stored in the device specified with (D).
- In the scaling, point data used for output value calculation must be searched from the input value, and the search method is specified with (S1). The search method is either sequential search or binary search, and the features are shown below. Specify the search method according to the intended use.

Search method	Search times when the number of points is 4000	Processing time	Precaution
Sequential search	1 to 4000 times	0.003 to 0.809 [ms] Since the data is searched in order from the head in sequential search, the maximum processing time increases in proportion to the number of points.	During search processing, whether the point data corresponding to the input value is in ascending order can be checked. If the input value is not in ascending order, an operation error will occur.
Binary search	12 times	0.006 [ms] Binary search requires relatively short search time since the processing time does not increase in proportion to the number of points.	During search processing, point data required for the binary search are only referred to. If the data is not in ascending order, the calculation result of output value could be unexpected one since all of the point data corresponding to the input value cannot be confirmed.

- The device No. specified with (S3) should be an even number. Set the point data in the specified device as follows.

Offset	Name	Description	Range
+0	The number of points (N)	Set the number of points for the scaling conversion data.	2 to 4000
+1	Unusable	Set 0.	0
+2	Point 0	Set the point data of (X ₀ , Y ₀) to (X _{N-1} , Y _{N-1}) so that the device No. is in consecutive order.	-32768 to 32767
+3			
+4	Point 1		
+5			
+6	Point 2		
+7			
⋮	⋮		
+(2N)	Point (N-1)		
+(2N+1)			

Point

Set the point data corresponding to the input value in ascending order. (Positive conversion: $X_0 < X_1 < \dots < X_{N-1}$, Inverse conversion: $Y_0 < Y_1 < \dots < Y_{N-1}$)

- When the conversion result to be stored in the device specified with (D) is not an integer value, its fractional portion is rounded down.

Operation error

An operation error will occur, and the conversion of input value will not be executed if:

- (S1) is set to other than 0 to 3.
- (S3) is not an even-numbered device.
- The number of points at the point table specified with (S3) is outside the range of 2 to 4000.
- Point table specified with (S3) is outside the device range.
- In sequential search ((S1) is 0 or 1.), the point corresponding to the input value (Positive conversion: X_0 to X_{N-1} , Inverse conversion: Y_0 to Y_{N-1}) is not in ascending order.
- The conversion result is outside the range of -32768 to 32767.

Program example

■ Program which sets 4 points of scaling conversion data to D3000 to D3009 and substitutes the output value, which is positively converted based on the input value "7500", to D3106

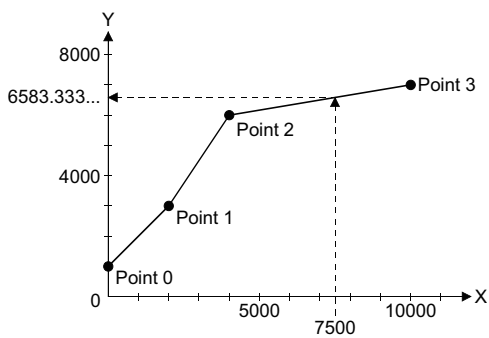
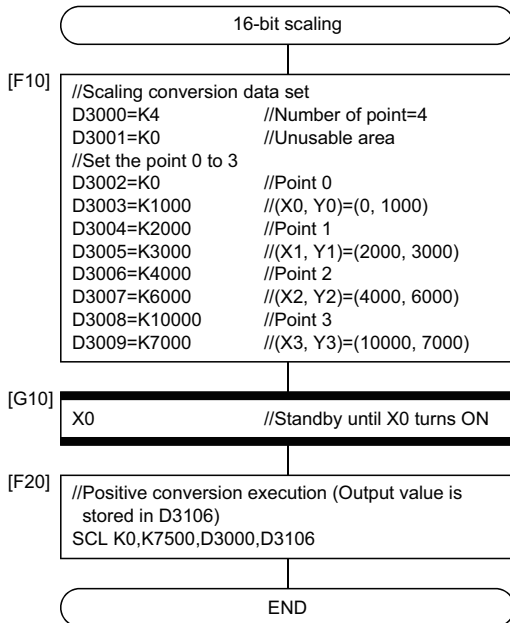

- The output value is calculated from the setting value of Point 2 and 3 since the input value "7500" is between point 2 and 3.

$$\text{Output value} = 6000 + \frac{7000 - 6000}{10000 - 4000} \times (7500 - 4000)$$

$$= 6583.333\dots$$

↓ A fractional portion is rounded down.

D3106 K6583

32-bit integer type scaling: DSCL

Format	Number of basic steps	Usable steps	
		F/FS	G
DSCL(S1), (S2), (S3), (D)	15	○	○

Setting data

■ Usable data

○: Usable

Setting data	Usable Data									
	Bit device	Word device			Constant			Calculation expression	Bit conditional expression	Comparison conditional expression
		16-bit integer type	32-bit integer type (L)	64-bit floating point type (F)	16-bit integer type (K/H)	32-bit integer type (K/H, L)	64-bit floating point type (K)			
(S1)	—	○	—	—	○	—	—	—	—	—
(S2)	—	—	○	—	—	○	—	○	—	—
(S3)	—	○	—	—	—	—	—	—	—	—
(D)	—	—	○	—	—	—	—	—	—	—

■ Description, data type of result

Setting data	Description	Data type of result
(S1)	Data which specifies the search/conversion method 0: Positive conversion by sequential search 1: Inverse conversion by sequential search 2: Positive conversion by binary search 3: Inverse conversion by binary search	—
(S2)	Input value for positive/inverse conversion	
(S3)	Start device No. which stores the scaling conversion data	
(D)	Device No. which stores the conversion result	

Processing details

- 32-bit integer type scaling calculates the output value from the set input value based on the scaling conversion data where a maximum of 2000 points data $((X_0, Y_0) \text{ to } (X_{N-1}, Y_{N-1}))$, N: the number of points) are defined. The point data corresponding to the input value should be set in ascending order. (Positive conversion: $X_0 < X_1 < \dots < X_{N-1}$, Inverse conversion: $Y_0 < Y_1 < \dots < Y_{N-1}$)
- The calculation method for output value is the same as 16-bit integer type scaling. (Page 162 When the input value is between two points of scaling conversion data, Page 162 When the input value is not between two points of scaling conversion data)

Point

When the input value is outside the scaling conversion data or calculation result of output value is outside the range of -2147483648 to 2147483647, an operation error will occur.

- Conversion of the input value specified with (S2) is executed according to the search/conversion method specified with (S1), using the scaling conversion data of device (S3) or later. The conversion result is stored in the device specified with (D).
- The setting method of (S1) is the same as 16-bit integer type scaling. (Page 161 16-bit integer type scaling: SCL)
- The device No. specified with (S3) should be an even number. Set the point data in the specified device as follows.

Offset	Name	Description	Range	
+0	Number of points (N)	Set the number of points for the scaling conversion data.	2 to 2000	
+1	Unusable	Set 0.	0	
+2	Point 0	Set the point data of (X ₀ , Y ₀) to (X _{N-1} , Y _{N-1}) so that the device No. is in consecutive order.	-2147483648 to 2147483647	
+3				X ₀
+4				Y ₀
+5				
+6	Point 1			
+7				X ₁
+8				Y ₁
+9				
+10	Point 2			
+11				X ₂
+12				Y ₂
+13				
⋮	⋮			
+(4N-2)	Point (N-1)			
+(4N-1)				X _{N-1}
+(4N)				Y _{N-1}
+(4N+1)				

Point

Set the point data corresponding to the input value in ascending order. (Positive conversion: X₀ < X₁ <.....< X_{N-1}, Inverse conversion: Y₀ < Y₁ <.....< Y_{N-1})

- When the conversion result to be stored in the device specified with (D) is not an integer value, its fractional portion is rounded down.

Operation error

An operation error will occur, and the conversion of input value will not be executed if:

- (S1) is set to other than 0 to 3.
- (S2), (S3), and (D) are not even-numbered devices.
- The number of points at the point table specified with (S3) is outside the range of 2 to 2000.
- Point table specified with (S3) is outside the device range.
- In sequential search ((S1) is 0 or 1.), the point corresponding to the input value (Positive conversion: X₀ to X_{N-1}, Inverse conversion: Y₀ to Y_{N-1}) is not in ascending order.
- The conversion result is outside the range of -2147483648 to 2147483647.

Program example

- Program which sets 4 points of scaling conversion data to D3000 to D3017 and substitutes the output value, which is positively converted based on the input value "-65000", to D3106L.

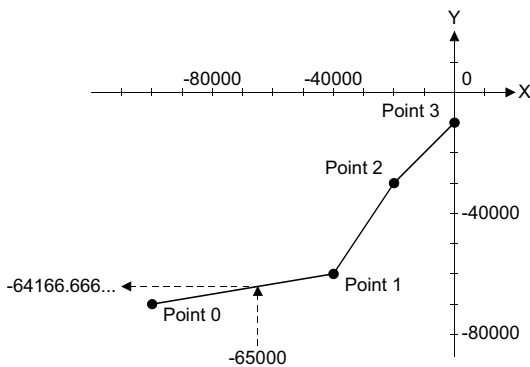
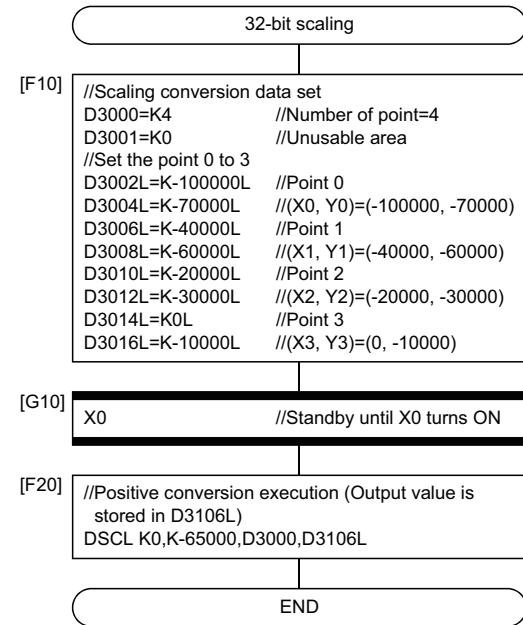

- The output value is calculated from the setting value of Point 0 and 1 since the input value "-65000" is between Point 0 and 1.

$$\text{Output value} = -70000 + \frac{(-60000 - (-70000))}{(-40000 - (-100000))} \times (-65000 - (-100000))$$

$$= -64166.666\dots$$

↓ A fractional portion is rounded down.

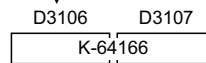

4.9 Type Conversions

Signed 16-bit integer value conversion: SHORT

Format	Number of basic steps	Usable steps	
		F/FS	G
SHORT(S)	4	<input type="radio"/>	<input type="radio"/>

Setting data

■ Usable data

○: Usable

Setting data	Usable Data									
	Bit device	Word device			Constant			Calculation expression	Bit conditional expression	Comparison conditional expression
		16-bit integer type	32-bit integer type (L)	64-bit floating point type (F)	16-bit integer type (K/H)	32-bit integer type (K/H, L)	64-bit floating point type (K)			
(S)	—	<input type="radio"/>	<input type="radio"/>	<input type="radio"/>	<input type="radio"/>	<input type="radio"/>	<input type="radio"/>	<input type="radio"/>	—	—

■ Description, data type of result

Setting data	Description	Data type of result
(S)	Data which will be converted into signed 16-bit integer value	16-bit integer type

Processing details

- The data specified with (S) is converted into a signed 16-bit integer value.
- The data range of (S) is -32768 to 32767.
- When (S) is a 64-bit floating-point type, its fractional portion is rounded down before conversion is made.
- If (S) is a 16-bit integer type, its value is returned unchanged, with no conversion processing performed.

Operation error

An operation error will occur if:

- The (S) data is outside the range -32768 to 32767.
- (S) is an indirectly specified device and its device No. is outside the range.

Program example

■ Program which converts the data of D0L into a signed 16-bit integer value and substitutes the result to #0

```
#0 = SHORT(D0L)
```



Unsigned 16-bit integer value conversion: USHORT

Format	Number of basic steps	Usable steps	
		F/FS	G
USHORT(S)	4	○	○

Setting data

Usable data

○: Usable

Setting data	Usable Data									
	Bit device	Word device			Constant			Calculation expression	Bit conditional expression	Comparison conditional expression
		16-bit integer type	32-bit integer type (L)	64-bit floating point type (F)	16-bit integer type (K/H)	32-bit integer type (K/H, L)	64-bit floating point type (K)			
(S)	—	○	○	○	○	○	○	○	—	—

Description, data type of result

Setting data	Description	Data type of result
(S)	Data which will be converted into unsigned 16-bit integer value	16-bit integer type

Processing details

- The data specified with (S) is converted into an unsigned 16-bit integer value.
- The data range of (S) is 0 to 65535.
- When (S) is a 64-bit floating-point type, its fractional portion is rounded down before conversion is made.
- If (S) is a 16-bit integer type, its value is returned unchanged, with no conversion processing performed.

Operation error

An operation error will occur if:

- The (S) data is outside the range 0 to 65535.
- (S) is an indirectly specified device and its device No. is outside the range.

Program example

Program which converts the data of D0L into an unsigned 16-bit integer value and substitutes the result to #0

```
#0 = USHORT(D0L)
```

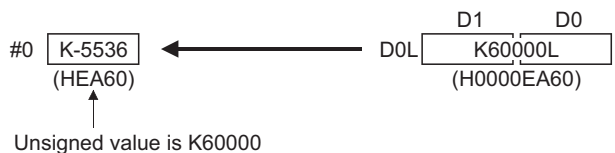

It is converted into a large data type to operate the binary operations with a different data type. Therefore, USHORT does not become valid. The target binary operations are shown below.

- Addition (+)
- Subtraction (-)
- Multiplication (*)
- Division (/)
- Remainder (%)
- Bit logical AND (&)
- Bit logical OR (|)
- Bit exclusive logical OR (^)

(Example)

W0: F=#0F+USHORT(DOL)

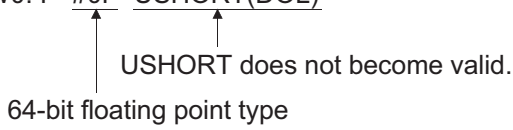

Signed 32-bit integer value conversion: LONG

Format	Number of basic steps	Usable steps	
		F/FS	G
LONG(S)	4	○	○

Setting data

Usable data

○: Usable

Setting data	Usable Data									
	Bit device	Word device			Constant			Calculation expression	Bit conditional expression	Comparison conditional expression
		16-bit integer type	32-bit integer type (L)	64-bit floating point type (F)	16-bit integer type (K/H)	32-bit integer type (K/H, L)	64-bit floating point type (K)			
(S)	—	○	○	○	○	○	○	○	—	—

Description, data type of result

Setting data	Description	Data type of result
(S)	Data which will be converted into signed 32-bit integer value	32-bit integer type

Processing details

- The data specified with (S) is converted into a signed 32-bit integer value.
- The data range of (S) is -2147483648 to 2147483647.
- When (S) is a 64-bit floating-point type, its fractional portion is rounded down before conversion is made.
- If (S) is a 32-bit integer type, its value is returned unchanged, with no conversion processing performed.

Operation error

An operation error will occur if:

- The (S) data is outside the range -2147483648 to 2147483647.
- (S) is an indirectly specified device and its device No. is outside the range.

Program example

Program which converts the data of D0 into a signed 32-bit integer value and substitutes the result to #0L

```
#0L = LONG(D0)
```



Unsigned 32-bit integer value conversion: ULONG

Format	Number of basic steps	Usable steps	
		F/FS	G
ULONG(S)	4	<input type="radio"/>	<input type="radio"/>

Setting data

Usable Data

: Usable

Setting data	Usable Data									
	Bit device	Word device			Constant			Calculation expression	Bit conditional expression	Comparison conditional expression
		16-bit integer type	32-bit integer type (L)	64-bit floating point type (F)	16-bit integer type (K/H)	32-bit integer type (K/H, L)	64-bit floating point type (K)			
(S)	—	<input type="radio"/>	<input type="radio"/>	<input type="radio"/>	<input type="radio"/>	<input type="radio"/>	<input type="radio"/>	<input type="radio"/>	—	—

Description, data type of result

Setting data	Description	Data type of result
(S)	Data which will be converted into unsigned 32-bit integer value	32-bit integer type

Processing details

- The data specified with (S) is converted into an unsigned 32-bit integer value.
- The data range of (S) is 0 to 4294967295.
- When (S) is a 64-bit floating-point type, its fractional portion is rounded down before conversion is made.
- If (S) is a 32-bit integer type, its value is returned unchanged, with no conversion processing performed.

Operation error

An operation error will occur if:

- The (S) data is outside the range 0 to 4294967295.
- (S) is an indirectly specified device and its device No. is outside the range.

Program example

Program which converts the data of D0 into an unsigned 32-bit integer value and substitutes the result to #0L

```
#0L = ULONG(D0)
```



Point 

It is converted into a large data type to operate the binary operations with a different data type. Therefore, ULONG does not become valid. The target binary operations are shown below.

- Addition (+)
- Subtraction (-)
- Multiplication (*)
- Division (/)
- Remainder (%)
- Bit logical AND (&)
- Bit logical OR (|)
- Bit exclusive logical OR (^)

(Example)

W0: F=#0F+ULONG(D0L)

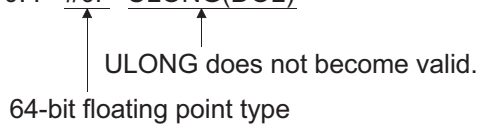

Signed 64-bit floating-point value conversion: FLOAT

Format	Number of basic steps	Usable steps	
		F/FS	G
FLOAT(S)	4	○	○

Setting data

Usable Data

○: Usable

Setting data	Usable Data									
	Bit device	Word device			Constant			Calculation expression	Bit conditional expression	Comparison conditional expression
		16-bit integer type	32-bit integer type (L)	64-bit floating point type (F)	16-bit integer type (K/H)	32-bit integer type (K/H, L)	64-bit floating point type (K)			
(S)	—	○	○	○	○	○	○	○	—	—

Description, data type of result

Setting data	Description	Data type of result
(S)	Data which will be converted into signed 64-bit floating-point value	64-bit floating-point type

Processing details

- The data specified with (S) is converted into a signed 64-bit floating-point value.
- If (S) is a 64-bit floating-point type, its value is returned unchanged, with no conversion processing performed.

Operation error

An operation error will occur if:

- (S) is an indirectly specified device and its device No. is outside the range.

Program example

Program which converts the data of D0L into a signed 64-bit floating-point value and substitutes the result to #0F

```
#0F = FLOAT(D0L)
```

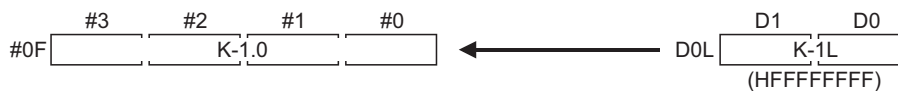

Unsigned 64-bit floating-point value conversion: UFLOAT

Format	Number of basic steps	Usable steps	
		F/FS	G
UFLOAT(S)	4	○	○

Setting data

Usable Data

○: Usable

Setting data	Usable Data									
	Bit device	Word device			Constant			Calculation expression	Bit conditional expression	Comparison conditional expression
		16-bit integer type	32-bit integer type (L)	64-bit floating point type (F)	16-bit integer type (K/H)	32-bit integer type (K/H, L)	64-bit floating point type (K)			
(S)	—	○	○	○	○	○	○	○	—	—

Description, data type of result

Setting data	Description	Data type of result
(S)	Data which will be converted into unsigned 64-bit floating-point value	64-bit floating-point type

Processing details

- The data specified with (S) is converted into an unsigned 64-bit floating-point value.
- If (S) is a 64-bit floating-point type, its value is returned unchanged, with no conversion processing performed.

Operation error

An operation error will occur if:

- (S) is an indirectly specified device and its device No. is outside the range.

Program example

Program which converts the data of D0L into an unsigned 64-bit floating-point value and substitutes the result to #0F

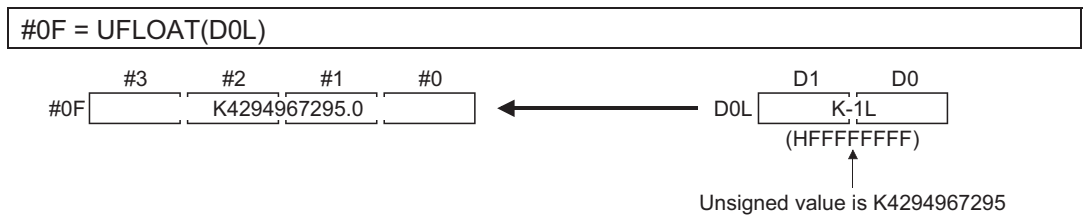

Floating-point value conversion 32-bit into 64-bit: DFLT

Format	Number of basic steps	Usable steps	
		F/FS	G
DFLT(S)	4	○	○

Setting data

■ Usable Data

○: Usable

Setting data	Usable Data									
	Bit device	Word device			Constant			Calculation expression	Bit conditional expression	Comparison conditional expression
		16-bit integer type	32-bit integer type (L)	64-bit floating point type (F)	16-bit integer type (K/H)	32-bit integer type (K/H, L)	64-bit floating point type (K)			
(S)	—	—	○*1	—	—	—	—	—	—	

*1 The data is handled as the 32-bit integer type on the program, but store the 32-bit floating-point data in the device.

■ Description, data type of result

Setting data	Description	Data type of result
(S)	Data which will be converted into 64-bit floating-point value	64-bit floating-point type

Processing details

- The 32-bit floating-point (single precision real number) value stored in the device specified with (S) is converted into the 64-bit floating-point (double precision real number) value. Convertible data ranges are shown below.
 -3.40×10^{38} to -1.18×10^{-38} , 0.0 , 1.18×10^{-38} to 3.40×10^{38} (single precision real number)
- The 64-bit floating-point type is used as the data of floating-point type in the Motion SFC program. Use this instruction to input the data of 32-bit floating-point type from the external devices.

Operation error

An operation error will occur if:

- The (S) data is not a valid 32-bit floating-point type.

Program example

■ Program which converts the 32-bit floating-point value data of D2000L into 64-bit floating-point value data and substitutes the result to #0F

```
#0F = DFLT(D2000L)
```



Floating-point value conversion 64-bit into 32-bit: SFLT

Format	Number of basic steps	Usable steps	
		F/FS	G
SFLT(S)	4	○	○

Setting data

Usable Data

○: Usable

Setting data	Usable Data									
	Bit device	Word device			Constant			Calculation expression	Bit conditional expression	Comparison conditional expression
		16-bit integer type	32-bit integer type (L)	64-bit floating point type (F)	16-bit integer type (K/H)	32-bit integer type (K/H, L)	64-bit floating point type (K)			
(S)	—	—	—	○	—	—	—	○	—	—

Description, data type of result

Setting data	Description	Data type of result
(S)	Data which will be converted into 32-bit floating-point value	32-bit floating-point type

Processing details

- The 64-bit floating-point (double precision real number) value stored in the device specified with (S) is converted into the 32-bit floating-point (single precision real number) value. Convertible data ranges are shown below.
 -3.40×10^{38} to -1.18×10^{-38} , 0.0, 1.18×10^{-38} to 3.40×10^{38} (single precision real number)
- The 64-bit floating-point type is used as the data of floating-point type in the Motion SFC program. Use this instruction to output the data into the external devices that cannot use the 64-bit floating-point type.

Point

The number of effective digits of 32-bit floating-point value data is approx. 7 digits. Data in the seven digits or later of conversion result by SFLT instruction may not match the (S) data.

Operation error

An operation error will occur if:

- The (S) data is not a valid 64-bit floating-point type.
- The (S) data after convert is outside the range of 32 bit floating-point type.

Program example

Program which converts the 64-bit floating-point value data of #0F into 32-bit floating-point value data and substitutes the result to D2000L

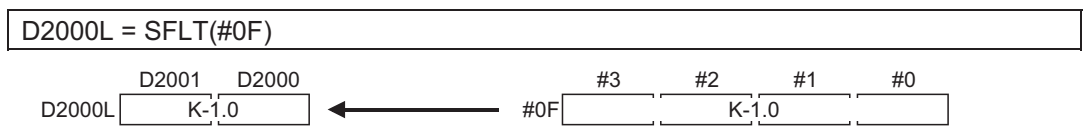

4.10 Bit Device Statuses

ON (Normally open contact): (None)

Format	Number of basic steps	Usable steps	
		F/FS	G
(S)	4	<input type="radio"/>	<input type="radio"/>

Setting data

■ Usable Data

: Usable

Setting data	Usable Data									
	Bit device	Word device			Constant			Calculation expression	Bit conditional expression	Comparison conditional expression
		16-bit integer type	32-bit integer type (L)	64-bit floating point type (F)	16-bit integer type (K/H)	32-bit integer type (K/H, L)	64-bit floating point type (K)			
(S)	<input type="radio"/>	—	—	—	—	—	—	—	—	—

■ Description, data type of result

Setting data	Description	Data type of result
(S)	Bit device used in bit conditional expression	Logical type (true/false)

Processing details

- True is returned when the bit device specified with (S) in a bit conditional expression is ON (1), or false is returned when that bit device is OFF (0).

Operation error

An operation error will occur if:

- (S) is an indirectly specified device and its device No. is outside the range.

Program example

■ Program which sets M100 when either of M0 and X0 is ON (1)

```
SET M100 = M0 + X0
```

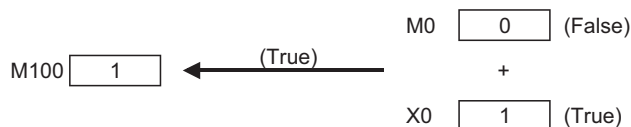

OFF (Normally closed contact): !

Format	Number of basic steps	Usable steps	
		F/FS	G
!(S)	4	○	○

Setting data

■ Usable Data

○: Usable

Setting data	Usable Data									
	Bit device	Word device			Constant			Calculation expression	Bit conditional expression	Comparison conditional expression
		16-bit integer type	32-bit integer type (L)	64-bit floating point type (F)	16-bit integer type (K/H)	32-bit integer type (K/H, L)	64-bit floating point type (K)			
(S)	○	—	—	—	—	—	—	—	—	—

■ Description, data type of result

Setting data	Description	Data type of result
(S)	Bit device used in bit conditional expression	Logical type (true/false)

Processing details

- True is returned when the bit device specified with (S) in a bit conditional expression is OFF (0), or false is returned when that bit device is ON (1).

Operation error

An operation error will occur if:

- (S) is an indirectly specified device and its device No. is outside the range.

Program example

■ Program which resets M100 when M0 is OFF (0)

```
RST M100 = !M0
```

M100 0 ← !M0 0 (True)

4.11 Bit Device Controls

Device set: SET

Format	Number of basic steps	Usable steps	
		F/FS	G
SET(D)=(S)	8	<input type="radio"/>	<input type="radio"/>

Setting data

■ Usable Data

○: Usable

Setting data	Usable Data									
	Bit device	Word device			Constant			Calculation expression	Bit conditional expression	Comparison conditional expression
		16-bit integer type	32-bit integer type (L)	64-bit floating point type (F)	16-bit integer type (K/H)	32-bit integer type (K/H, L)	64-bit floating point type (K)			
(D)	<input type="radio"/>	—	—	—	—	—	—	—	—	—
(S)	<input type="radio"/>	—	—	—	—	—	—	—	<input type="radio"/>	<input type="radio"/>

■ Description, data type of result

Setting data	Description	Data type of result
(D)	Bit data for device set	Bit logical type (true/false)
(S)	Condition data which determines whether device set will be performed or not	

Processing details

- If the data specified with (S) is true, the bit data specified with (D) is set.
- (S) can be omitted. At this time, the format is "SET(D)" and device set is made unconditionally.
- When this instruction is set as a transition condition in the last block of a transition program, whether the data specified with (S) is true or false is returned as logical type data. In this case, (S) cannot be omitted.

Operation error

An operation error will occur if:

- (D) or (S) is an indirectly specified device and its device No. is outside the range.

Program example

■ Program which sets M100 when either of M0 and X0 is 1

```
SET M100 = M0 + X0
```



■ Program which sets M100 when #0 is equal to D0

```
SET M100 = #0 == D0
```



■ Program which sets Y0 unconditionally

```
SET Y0
```



Device reset: RST

Format	Number of basic steps	Usable steps	
		F/FS	G
RST(D)=(S)	8	○	○

Setting data

Usable Data

○: Usable

Setting data	Usable Data									
	Bit device	Word device			Constant			Calculation expression	Bit conditional expression	Comparison conditional expression
		16-bit integer type	32-bit integer type (L)	64-bit floating point type (F)	16-bit integer type (K/H)	32-bit integer type (K/H, L)	64-bit floating point type (K)			
(D)	○	—	—	—	—	—	—	—	—	—
(S)	○	—	—	—	—	—	—	—	○	○

Description, data type of result

Setting data	Description	Data type of result
(D)	Bit data for device reset	Bit logical type (true/false)
(S)	Condition data which determines whether device reset will be performed or not	

Processing details

- If the data specified with (S) is true, the bit data specified with (D) is reset.
- (S) can be omitted. At this time, the format is "RST(D)" and device reset is made unconditionally.
- When this instruction is set as a transition condition in the last block of a transition program, whether the data specified with (S) is true or false is returned as logical type data. In this case, (S) cannot be omitted.

Operation error

An operation error will occur if:

- (D) or (S) is an indirectly specified device and its device No. is outside the range.

Program example

Program which resets M100 when either of M0 and X0 is 1

```
RST M100 = M0 + X0
```



Program which resets M100 when #0 is equal to D0

```
RST M100 = #0 != D0
```



Program which resets Y0 unconditionally

```
RST Y0
```



Device output: DOUT

Format	Number of basic steps	Usable steps	
		F/FS	G
DOUT (D),(S)	8	○	○

Setting data

■ Usable Data

○: Usable

Setting data	Usable Data									
	Bit device	Word device			Constant			Calculation expression	Bit conditional expression	Comparison conditional expression
		16-bit integer type	32-bit integer type (L)	64-bit floating point type (F)	16-bit integer type (K/H)	32-bit integer type (K/H, L)	64-bit floating point type (K)			
(D)	○	—	—	—	—	—	—	—	—	—
(S)	—	○	○	—	○	○	—	○	—	—

■ Description, data type of result

Setting data	Description	Data type of result
(D)	Output destination bit data	Batch bit
(S)	Output source data	

Processing details

- The data specified with (S) is output to the bit data specified with (D).
- Specify a multiple of 16 as the device No. of the bit data specified with (D).
- If the type of (S) is a 16-bit integer type, 16 points of the (S) data, starting at the least significant bit, are output in order to the bit devices headed by the one specified with (D).
- If the type of (S) is a 32-bit integer type, 32 points of the (S) data, starting at the least significant bit, are output in order to the bit devices headed by the one specified with (D).

Operation error

An operation error will occur if:

- (D) or (S) is an indirectly specified device and its device No. is outside the range.
- (D) is an indirectly specified device and its device No. is not a multiple of 16.

Program example

■ Program which outputs the data of D0 to Y0-YF

DOUT Y0, D0



Device input: DIN

Format	Number of basic steps	Usable steps	
		F/FS	G
DIN (D),(S)	8	○	○

Setting data

■ Usable Data

○: Usable

Setting data	Usable Data									
	Bit device	Word device			Constant			Calculation expression	Bit conditional expression	Comparison conditional expression
		16-bit integer type	32-bit integer type (L)	64-bit floating point type (F)	16-bit integer type (K/H)	32-bit integer type (K/H, L)	64-bit floating point type (K)			
(D)	—	○	○	—	—	—	—	—	—	
(S)	○	—	—	—	—	—	—	—	—	

■ Description, data type of result

Setting data	Description	Data type of result
(D)	Input destination data	Data type of (D) (Integer type)
(S)	Input source bit data	

Processing details

- The bit data specified with (S) is input to the data specified with (D).
- Specify a multiple of 16 as the device No. of the bit data specified with (S).
- If the type of (D) is a 16-bit integer type, 16 points of the (D) data, starting at the least significant bit, are input in order to the bit devices headed by the one specified with (S).
- If the type of (D) is a 32-bit integer type, 32 points of the (D) data, starting at the least significant bit, are input in order to the bit devices headed by the one specified with (S).

Operation error

An operation error will occur if:

- (D) or (S) is an indirectly specified device and its device No. is outside the range.
- (S) is an indirectly specified device and its device No. is not a multiple of 16.

Program example

■ Program which inputs the data of X0-XF to D0

DIN D0, X0



Bit device output: OUT

Format	Number of basic steps	Usable steps	
		F/FS	G
OUT(D)=(S)	8	○	○

Setting data

■ Usable Data

○: Usable

Setting data	Usable Data									
	Bit device	Word device			Constant			Calculation expression	Bit conditional expression	Comparison conditional expression
		16-bit integer type	32-bit integer type (L)	64-bit floating point type (F)	16-bit integer type (K/H)	32-bit integer type (K/H, L)	64-bit floating point type (K)			
(D)	○	—	—	—	—	—	—	—	—	—
(S)	○	—	—	—	—	—	—	—	○	○

■ Description, data type of result

Setting data	Description	Data type of result
(D)	Bit device for device output	Bit logical type (true/false)
(S)	Condition data which determines device output	

Processing details

- If the data specified with (S) is true, the bit data specified with (D) is set, and if the data specified with (S) is false, the bit data specified with (D) is reset.
- When this instruction is set as a transition condition in the last block of a transient program, whether the data specified with (S) is true or false is returned as logical type data.
- In this case, (S) cannot be omitted.

Operation error

An operation error will occur if:

- (D) or (S) is an indirectly specified device and its device No. is outside the range.

Program example

■ Program which sets M100 when M0 is ON (1) and program which resets M100 when M0 is OFF (0)

```
OUT M100 = M0
```

■ Program which sets M100 when M0 and M1 are both on and resets M100 except it

```
OUT M100 = M0 * M1
```

■ Program which sets M100 when D0 is equal to D2000 and resets M100 when D is not equal to D2000

```
OUT M100 = (D0 == D2000)
```

4.12 Logical Operations

Logical acknowledgement: (None)

Format	Number of basic steps	Usable steps	
		F/FS	G
(S)	—	○	○

Setting data

■ Usable Data

○: Usable

Setting data	Usable Data									
	Bit device	Word device			Constant			Calculation expression	Bit conditional expression	Comparison conditional expression
		16-bit integer type	32-bit integer type (L)	64-bit floating point type (F)	16-bit integer type (K/H)	32-bit integer type (K/H, L)	64-bit floating point type (K)			
(S)	○	—	—	—	—	—	—	—	○	○

■ Description, data type of result

Setting data	Description	Data type of result
(S)	Data which will be logically acknowledged	Logical type (true/false)

Processing details

- Whether the logical type data specified with (S) is true or false is returned unchanged. (Logical acknowledgement)

Operation error

An operation error will occur if:

- (S) is an indirectly specified device and its device No. is outside the range.

Program example

■ Program which sets M100 when either of M0 and X0 is ON (1)

```
SET M100 = M0 + X0
```

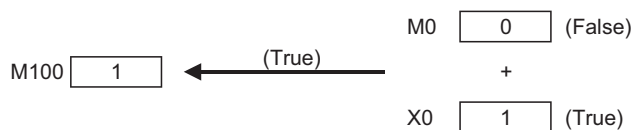

Logical negation: !

Format	Number of basic steps	Usable steps	
		F/FS	G
!(S)	4	○	○

Setting data

■ Usable Data

○: Usable

Setting data	Usable Data									
	Bit device	Word device			Constant			Calculation expression	Bit conditional expression	Comparison conditional expression
		16-bit integer type	32-bit integer type (L)	64-bit floating point type (F)	16-bit integer type (K/H)	32-bit integer type (K/H, L)	64-bit floating point type (K)			
(S)	○	—	—	—	—	—	—	—	○	○

■ Description, data type of result

Setting data	Description	Data type of result
(S)	Data which will be logically negated	Logical type (true/false)

Processing details

- The data specified with (S) is logically negated.

Operation error

An operation error will occur if:

- (S) is an indirectly specified device and its device No. is outside the range.

Program example

■ Program which sets M100 when "either of M0 and X0 is not ON (1)" (when M0 and X0 are both OFF (0))

```
SET M100 = !(M0 + X0)
```

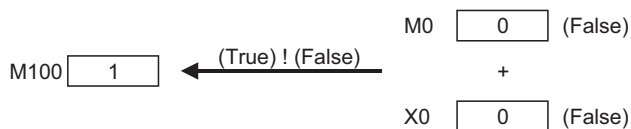

Logical AND: *

Format	Number of basic steps	Usable steps	
		F/FS	G
(S1)*(S2)	7	○	○

Setting data

■ Usable Data

○: Usable

Setting data	Usable Data									
	Bit device	Word device			Constant			Calculation expression	Bit conditional expression	Comparison conditional expression
		16-bit integer type	32-bit integer type (L)	64-bit floating point type (F)	16-bit integer type (K/H)	32-bit integer type (K/H, L)	64-bit floating point type (K)			
(S1)	○	—	—	—	—	—	—	—	○	○
(S2)	○	—	—	—	—	—	—	—	○	○

■ Description, data type of result

Setting data	Description	Data type of result
(S1)	Data which will be ANDed	Logical type (true/false)
(S2)		

Processing details

- The data specified with (S1) and the data specified with (S2) are ANDed.

Operation error

An operation error will occur if:

- (S) is an indirectly specified device and its device No. is outside the range.

Program example

■ Program which sets M100 when M0 and X0 are both 1

```
SET M100 = M0 * X0
```

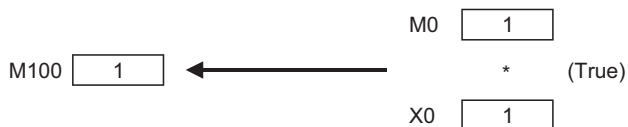

Logical OR: +

Format	Number of basic steps	Usable steps	
		F/FS	G
(S1)+(S2)	7	○	○

Setting data

■ Usable Data

○: Usable

Setting data	Usable Data									
	Bit device	Word device			Constant			Calculation expression	Bit conditional expression	Comparison conditional expression
		16-bit integer type	32-bit integer type (L)	64-bit floating point type (F)	16-bit integer type (K/H)	32-bit integer type (K/H, L)	64-bit floating point type (K)			
(S1)	○	—	—	—	—	—	—	—	○	○
(S2)	○	—	—	—	—	—	—	—	○	○

■ Description, data type of result

Setting data	Description	Data type of result
(S1)	Data which will be ORed	Logical type (true/false)
(S2)		

Processing details

- The data specified with (S1) and the data specified with (S2) are ORed.

Operation error

An operation error will occur if:

- (S1) or (S2) is an indirectly specified device and its device No. is outside the range.

Program example

■ Program which sets M100 when either of M0 and X0 is 1

```
SET M100 = M0 + X0
```



4.13 Comparison Operations

Equal to: ==

Format	Number of basic steps	Usable steps	
		F/FS	G
(S1)==(S2)	7	○	○

Setting data

■ Usable Data

○: Usable

Setting data	Usable Data									
	Bit device	Word device			Constant			Calculation expression	Bit conditional expression	Comparison conditional expression
		16-bit integer type	32-bit integer type (L)	64-bit floating point type (F)	16-bit integer type (K/H)	32-bit integer type (K/H, L)	64-bit floating point type (K)			
(S1)	—	○	○	○	○	○	○	○	—	—
(S2)	—	○	○	○	○	○	○	○	—	—

■ Description, data type of result

Setting data	Description	Data type of result
(S1)	Data which will be compared	Logical type (true/false)
(S2)		

Processing details

- The data specified with (S1) and the data specified with (S2) are compared, and the result is true if they are equal.
- When (S1) and (S2) differ in data type, the data of the smaller data type is converted into that of the greater type before comparison is performed.

Operation error

An operation error will occur if:

- (S1) or (S2) is an indirectly specified device and its device No. is outside the range.

Program example

■ Program which compares whether #0 and D0 are equal or not

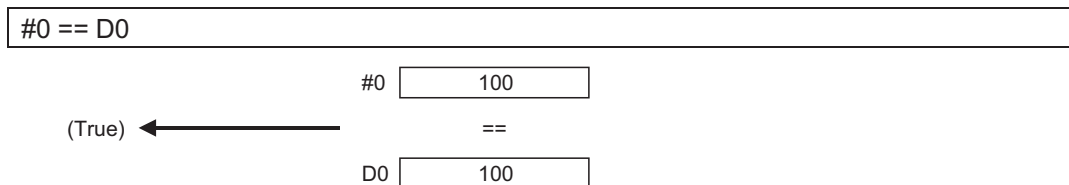

Not equal to: !=

Format	Number of basic steps	Usable steps	
		F/FS	G
(S1)!=(S2)	7	<input type="radio"/>	<input type="radio"/>

Setting data

■ Usable Data

○: Usable

Setting data	Usable Data									
	Bit device	Word device			Constant			Calculation expression	Bit conditional expression	Comparison conditional expression
		16-bit integer type	32-bit integer type (L)	64-bit floating point type (F)	16-bit integer type (K/H)	32-bit integer type (K/H, L)	64-bit floating point type (K)			
(S1)	—	<input type="radio"/>	<input type="radio"/>	<input type="radio"/>	<input type="radio"/>	<input type="radio"/>	<input type="radio"/>	<input type="radio"/>	—	—
(S2)	—	<input type="radio"/>	<input type="radio"/>	<input type="radio"/>	<input type="radio"/>	<input type="radio"/>	<input type="radio"/>	<input type="radio"/>	—	—

■ Description, data type of result

Setting data	Description	Data type of result
(S1)	Data which will be compared	Logical type (true/false)
(S2)		

Processing details

- The data specified with (S1) and the data specified with (S2) are compared, and the result is true if they are not equal.
- When (S1) and (S2) differ in data type, the data of the smaller data type is converted into that of the greater type before comparison is performed.

Operation error

An operation error will occur if:

- (S1) or (S2) is an indirectly specified device and its device No. is outside the range.

Program example

■ Program which compares whether #0 and D0 are unequal or not

```
#0 != D0
```

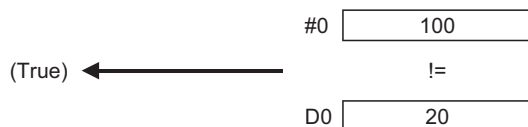

Less than: <

Format	Number of basic steps	Usable steps	
		F/FS	G
(S1)<(S2)	7	○	○

Setting data

■ Usable Data

○: Usable

Setting data	Usable Data									
	Bit device	Word device			Constant			Calculation expression	Bit conditional expression	Comparison conditional expression
		16-bit integer type	32-bit integer type (L)	64-bit floating point type (F)	16-bit integer type (K/H)	32-bit integer type (K/H, L)	64-bit floating point type (K)			
(S1)	—	○	○	○	○	○	○	○	—	—
(S2)	—	○	○	○	○	○	○	○	—	—

■ Description, data type of result

Setting data	Description	Data type of result
(S1)	Data which will be compared	Logical type (true/false)
(S2)		

Processing details

- The result is true if the data specified with (S1) is less than the data specified with (S2).
- When (S1) and (S2) differ in data type, the data of the smaller data type is converted into that of the greater type before comparison is performed.

Operation error

An operation error will occur if:

- (S1) or (S2) is an indirectly specified device and its device No. is outside the range.

Program example

■ Program which compares whether #0 is less than D0 or not

```
#0 < D0
```

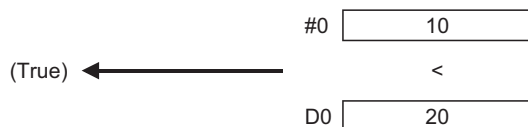

Less than or equal to: <=

Format	Number of basic steps	Usable steps	
		F/FS	G
(S1)<=(S2)	7	○	○

Setting data

■ Usable Data

○: Usable

Setting data	Usable Data									
	Bit device	Word device			Constant			Calculation expression	Bit conditional expression	Comparison conditional expression
		16-bit integer type	32-bit integer type (L)	64-bit floating point type (F)	16-bit integer type (K/H)	32-bit integer type (K/H, L)	64-bit floating point type (K)			
(S1)	—	○	○	○	○	○	○	○	—	—
(S2)	—	○	○	○	○	○	○	○	—	—

■ Description, data type of result

Setting data	Description	Data type of result
(S1)	Data which will be compared	Logical type (true/false)
(S2)		

Processing details

- The result is true if the data specified with (S1) is less than or equal to the data specified with (S2).
- When (S1) and (S2) differ in data type, the data of the smaller data type is converted into that of the greater type before comparison is performed.

Operation error

An operation error will occur if:

- (S1) or (S2) is an indirectly specified device and its device No. is outside the range.

Program example

■ Program which compares whether #0 is less than or equal to D0 or not

```
#0 <= D0
```

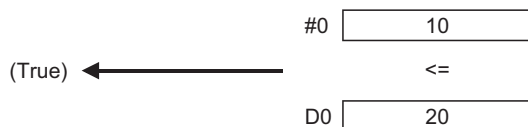

More than: >

Format	Number of basic steps	Usable steps	
		F/FS	G
(S1)>(S2)	7	○	○

Setting data

■ Usable Data

○: Usable

Setting data	Usable Data									
	Bit device	Word device			Constant			Calculation expression	Bit conditional expression	Comparison conditional expression
		16-bit integer type	32-bit integer type (L)	64-bit floating point type (F)	16-bit integer type (K/H)	32-bit integer type (K/H, L)	64-bit floating point type (K)			
(S1)	—	○	○	○	○	○	○	○	—	—
(S2)	—	○	○	○	○	○	○	○	—	—

■ Description, data type of result

Setting data	Description	Data type of result
(S1)	Data which will be compared	Logical type (true/false)
(S2)		

Processing details

- The result is true if the data specified with (S1) is greater than the data specified with (S2).
- When (S1) and (S2) differ in data type, the data of the smaller data type is converted into that of the greater type before comparison is performed.

Operation error

An operation error will occur if:

- (S1) or (S2) is an indirectly specified device and its device No. is outside the range.

Program example

■ Program which compares whether #0 is greater than D0 or not

```
#0 > D0
```

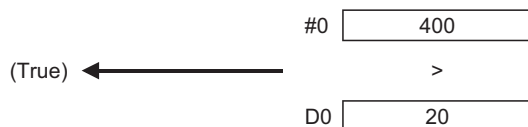

More than or equal to: >=

Format	Number of basic steps	Usable steps	
		F/FS	G
(S1)>=(S2)	7	○	○

Setting data

■ Usable Data

○: Usable

Setting data	Usable Data									
	Bit device	Word device			Constant			Calculation expression	Bit conditional expression	Comparison conditional expression
		16-bit integer type	32-bit integer type (L)	64-bit floating point type (F)	16-bit integer type (K/H)	32-bit integer type (K/H, L)	64-bit floating point type (K)			
(S1)	—	○	○	○	○	○	○	○	—	—
(S2)	—	○	○	○	○	○	○	○	—	—

■ Description, data type of result

Setting data	Description	Data type of result
(S1)	Data which will be compared	Logical type (true/false)
(S2)		

Processing details

- The result is true if the data specified with (S1) is greater than or equal to the data specified with (S2).
- When (S1) and (S2) differ in data type, the data of the smaller data type is converted into that of the greater type before comparison is performed.

Operation error

An operation error will occur if:

- (S1) or (S2) is an indirectly specified device and its device No. is outside the range.

Program example

■ Program which compares whether #0 is greater than or equal to D0 or not

```
#0 >= D0
```

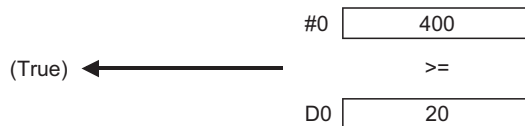

4.14 Program Control

Conditional branch control: IF - ELSE - IEND

Format	Number of basic steps	Usable steps	
		F/FS	G
IF(S) - ELSE - IEND	IF: 8 ELSE: 5 IEND: 1	○	○

Setting data

■ Usable Data

○: Usable

Setting data	Usable Data									
	Bit device	Word device			Constant			Calculation expression	Bit conditional expression	Comparison conditional expression
		16-bit integer type	32-bit integer type (L)	64-bit floating point type (F)	16-bit integer type (K/H)	32-bit integer type (K/H, L)	64-bit floating point type (K)			
(S)	○	—	—	—	—	—	—	—	○	○

■ Description, data type of result

Setting data	Description	Data type of result
(S)	Conditional data which controls the flow of program	—

Processing details

- If the data specified with (S) is true, the block between IF and ELSE is executed.
- If the data specified with (S) is false, the block between ELSE and IEND is executed.
- ELSE can be omitted. In that case, the block between IF and IEND is executed only when the data specified with (S) is true.
- Maximum multiplicities of conditional branch control are eight including selective branch control. (SELECT - CASE - SEND)

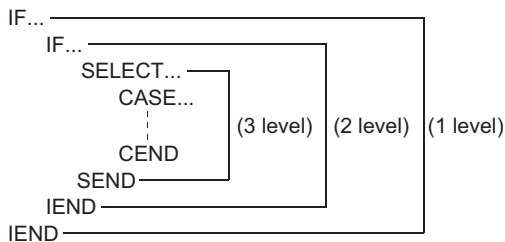

Operation error

In the following case, an operation error will occur, and the corresponding Motion SFC program No. execution will be stopped. For the subroutine called program, the call source program also stops to execute.

- (S) is indirectly specified device, and the device No. is outside the range.

Program example

- **Program which adds K10 to #100 when #0 is K100 or adds K20 to #100 when #0 is other than K100**

```
IF #0 == K100
  #100 = #100 + K10
ELSE
  #100 = #100 + K20
IEND
```

- **Program which executes the speed change of axis 2 with CHGV instruction when M0 or M1 is ON**

```
IF M0 + M1
  CHGV(K2, K10)
IEND
```

Selective branch control: SELECT - CASE - SEND

Format	Number of basic steps	Usable steps	
		F/FS	G
SELECT CASE(S1) - CEND CASE(S2) - CEND ⋮ CASE(Sn) - CEND CELSE - CEND SEND	SELECT: 1 CASE: 8 CEND: 5 CELSE: 1 SEND: 1	○	○

Setting data

■ Usable Data

○: Usable

Setting data	Usable Data									
	Bit device	Word device			Constant			Calculation expression	Bit conditional expression	Comparison conditional expression
		16-bit integer type	32-bit integer type (L)	64-bit floating point type (F)	16-bit integer type (K/H)	32-bit integer type (K/H, L)	64-bit floating point type (K)			
(S) to (Sn)	○	—	—	—	—	—	—	—	○	○

■ Description, data type of result

Setting data	Description	Data type of result
(S) to (Sn)	Conditional data which controls the flow of program	—

Processing details

- The block described between CASE and CEND is executed selectively according to the true/false of the data specified with (S1) to (Sn).
- The true/false evaluation is carried out in order from the top, and the block described between CASE which is first evaluated to be true and CEND is executed. After that, no true/false evaluation is carried out until SEND, and the next block of SEND is executed.
- When the data specified with (S1) to (Sn) are all false, the block described from CELSE to CEND is executed.
- CELSE can be omitted. In that case, if the data specified with (S1) to (Sn) are all false, the block between SELECT and SEND is not executed, and the next block of SEND is executed.
- The following number of CASE(Sn) to CEND can be written between SELECT and SEND

CELSE	Number
Not used	64
Used	63

- Maximum multiplicities of selective branch control are eight including conditional branch control. (IF - ELSE - IEND)

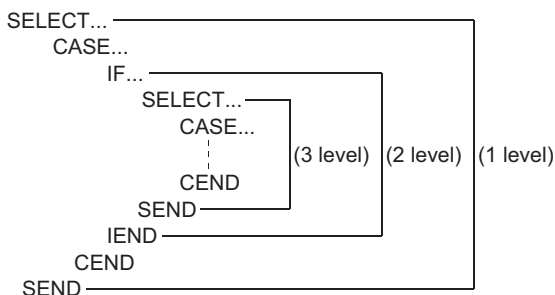

Operation error

In the following case, an operation error will occur, and the corresponding Motion SFC program No. execution will be stopped.
For the subroutine called program, the call source program also stops to execute.

- (S) is indirectly specified device, and the device No. is outside the range.

Program example

■ **Program which adds K10 to #100 when #0 is K100, adds K20 to #100 when #0 is K200 or more, or adds K100 to #100 in other cases**

```
SELECT
  CASE #0 == K100
    #100 = #100 + K10
  CEND
  CASE #0 >= K200
    #100 = #100 + K20
  CEND
  CELSE
    #100 = #100 + K100
  CEND
SEND
```

Repeat control with specified count: FOR - NEXT

Format	Number of basic steps	Usable steps	
		F/FS	G
FOR(D) = (S1)TO(S2)STEP(S3) - NEXT	FOR: 18 NEXT: 15	○	○

Setting data

■ Usable Data

○: Usable

Setting data	Usable Data									
	Bit device	Word device			Constant			Calculation expression	Bit conditional expression	Comparison conditional expression
		16-bit integer type	32-bit integer type (L)	64-bit floating point type (F)	16-bit integer type (K/H)	32-bit integer type (K/H, L)	64-bit floating point type (K)			
(D)	—	○	○	○	—	—	—	—	—	
(S1)	—	○	○	○	○	○	○	—	—	
(S2)	—	○	○	○	○	○	○	—	—	
(S3)	—	—	—	—	○	○	○	—	—	

■ Description, data type of result

Setting data	Description	Data type of result
(D)	Device used for loop control counter	—
(S1)	Initial value of loop control counter	
(S2)	Final value of loop control counter	
(S3)	Incremental value of loop control counter	

Processing details

- (S1) is substituted to the device specified with (D) as initial value, and the block between FOR and NEXT is repeatedly executed.
- The incremental value specified with (S3) is added to the device specified with (D) at every execution of NEXT. If the device value specified with (D) is larger than the final value specified with (S2), the repeat control of the block between FOR and NEXT is ended, and the next block of NEXT is executed.
- When the incremental value specified with (S3) is negative number, if the device value specified with (D) is smaller than the final value specified with (S2), the repeat control of the block between FOR and NEXT is ended.
- STEP can be omitted. If STEP is omitted, the repeat control is executed as "STEP 1".
- Maximum multiplicities of repeat control are eight.

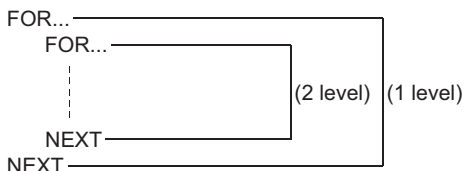

- When data types of (D), (S1), (S2) and (S3) are different, type conversion processing is executed but an unintended operation may occur. Set the same data type.

Operation error

In the following case, an operation error will occur, and the corresponding Motion SFC program No. execution will be stopped. For the subroutine called program, the call source program also stops to execute.

- (S1) data is outside the range of (D) data type.
- (D), (S1), and (S2) are indirectly specified devices, and the device No. is outside the range.
- FOR to NEXT instruction is executed over the limited count for repeat control set in parameter in an operation control program or a transition program.

Program example

■ Program which repeats to substitute #0 data to Motion register (#) that is indirectly specified with the device No. "#0+100" when #0 is between 1 and 10 (Incremental value is 1.)

When the program is ended, 1 to 10 is substituted to #101 to #110.

```
FOR #0 = K1 TO K10
  #(#0 + K100) = #0
NEXT
```

When the incremental value is positive number, the device value specified with (D) is larger than the final value specified with (S2) after FOR to NEXT repeat is completed. In the above example, #0 set in (D) is 11.

■ Program which repeats to subtract #0 from #100 when #0 is between 100 to 10 (Incremental value is -10.).

```
FOR #0 = K100 TO K10 STEP K-10
  #100 = #100 - #0
NEXT
```

When the incremental value is negative number, the device value specified with (D) is smaller than the final value specified with (S2) after FOR to NEXT repeat is completed. In the above example, #0 set in (D) is 0.

Point

Since the incremental value continues to be added to the loop control counter specified with (D) until it reaches the final value, set the data type which the value can handle. When the data range exceeds the loop control counter range, an unintended repeat operation may occur as the value is considered to be wrong. In the following program, the data type of loop control counter #0 is 16-bit integer type, and the data range is from -32768 to 32767.

```
FOR #0 = K0 TO K30000 STEP K10000
  #1 = #1 + K1
NEXT
```

When this program is executed, #0 changes as follows and exceeds the 16-bit integer type data range in the middle. Therefore, the program is not ended with four executions of the loop.

- First execution of the loop: #0 is 0.
- Second execution of the loop: #0 is 10000.
- Third execution of the loop: #0 is 20000.
- Forth execution of the loop: #0 is 30000.
- Fifth execution of the loop: #0 is -25536. (#0 is 40000, but overflow will occur as it is outside the data range.)
- Sixth execution of the loop: #0 is -15536.
- :

Forced termination of repeat control: BREAK

Format	Number of basic steps	Usable steps	
		F/FS	G
BREAK	5	○	○

Setting data

There are no setting data.

Processing details

- Repeat control with specified count (FOR - NEXT instruction) is forced to terminate, and the program from the next block of NEXT is executed.
- BREAK is only described within the repeat control processing block between FOR and NEXT.

4

Operation error

There are no operation errors.

Program example

■ Program which forces to terminate the repeat control processing by FOR to NEXT when M0 or M1 turns ON

```
FOR #0 = K1 TO K10
  #100 = #100 + K10
  IF M0 + M1
    BREAK
  IEND
NEXT
```

4.15 Motion-Dedicated Functions

Speed change request: CHGV

Format	Number of basic steps	Usable steps	
		F/FS	G
CHGV((S1), (S2))	7	○	○

Setting data

■ Usable Data

○: Usable

Setting data	Usable Data									
	Bit device	Word device			Constant			Calculation expression	Bit conditional expression	Comparison conditional expression
		16-bit integer type	32-bit integer type (L)	64-bit floating point type (F)	16-bit integer type (K/H)	32-bit integer type (K/H, L)	64-bit floating point type (K)			
(S1)	—	○	—	—	○	—	—	—	—	—
(S2)	—	○	○	—	○	○	—	○	—	—

■ Description, data type of result

Setting data	Description	Data type of result
(S1)	Axis No. to which speed change request will be given	—
(S2)	Specified speed	—

Processing details

- A speed change is made shown below.
- The "[St.1047] Speed change accepting flag (R: M30144+n/Q: M2061+n)" correspond to the axis specified with (S1) is turned ON.
 - The speed of the axis specified with (S1) is changed to the speed specified with (S2).
 - The speed change accepting flag is turned OFF.
- The axis No. that may be set at (S1) is within the following range.

Motion CPU	Setting range
R64MTCPU	1 to 64
R32MTCPU	1 to 32
R16MTCPU	1 to 16

- For interpolation control, set any one of the interpolation axes to (S1). When linear interpolation control is exercised, a speed change varies as described below with the positioning speed designation method set in the servo program.

Positioning speed designation method	Operation
Vector speed designation	Speed change is made so that the vector speed becomes the speed specified with (S2).
Longest axis designation	Speed change is made so that the longest axis speed becomes the speed specified with (S2).
Reference axis speed designation	Speed change is made so that the reference axis speed becomes the speed specified with (S2).

- Operation varies with the sign of the specified speed set at (S2).

Sign of specified speed	Operation
Positive	Speed change
0	Temporary stop
Negative	Return

- The specified speed that may be set at (S2) is within the following range.

Requested operation	Setting range			
	mm	inch	degree	pulse
Speed change request	0 to 600000000 ($\times 10^{-2}$ [mm/min])	0 to 600000000 ($\times 10^{-3}$ [inch/min])	0 to 2147483647 ($\times 10^{-3}$ [degree/min]) ^{*1}	0 to 2147483647 [pulse/s]
Return request	-1 to -600000000 ($\times 10^{-2}$ [mm/min])	-1 to -600000000 ($\times 10^{-3}$ [inch/min])	-1 to -2147483647 ($\times 10^{-3}$ [degree/min]) ^{*1}	-1 to -2147483647 [pulse/s]

*1 When the "speed control 10 × multiplier setting for degree axis" is set to "valid" in the fixed parameter, the unit is ($\times 10^{-2}$ [degree/min]).

- The speed changed by CHGV instruction is effective only on the servo program during starting.
- Speed change is not executed for the axis specified with (S1) during deceleration stop.
- Speed change is not executed for the axis specified with (S1) during speed-torque control.
- Speed change is not executed for the axis specified with (S1) during machine control (machine JOG operation, machine program operation).
- Acceleration/deceleration time at speed change can be changed by setting the acceleration/deceleration time change parameter of the axis specified with (S1). Refer to the following for acceleration/deceleration time change parameter and acceleration/deceleration time change function.
 MELSEC iQ-R Motion controller Programming Manual (Positioning Control)
- By specifying a negative speed and making a speed change request during the start, allows the axis to start deceleration at that point and return in the opposite direction upon completion of deceleration. The following operations by the servo instruction are shown below.

Control mode	Servo instruction	Operation
Linear control	<div style="display: flex; gap: 5px;"> ABS-1 ABS-2 ABS-3 ABS-4 </div> <div style="display: flex; gap: 5px; margin-top: 5px;"> INC-1 INC-2 INC-3 INC-4 </div>	On completion of deceleration, the axis reverses its moving direction, returns to the positioning starting point at the absolute value of the specified speed, and stops (waits) there. For circular interpolation, the axis returns in the circular path.
Circular interpolation control	<div style="display: flex; gap: 5px;"> ABS circular INC circular </div>	
Fixed-pitch feed	<div style="display: flex; gap: 5px;"> FEED-1 FEED-2 FEED-3 </div>	
Continuous trajectory control	<div style="display: flex; gap: 5px;"> CPSTART1 CPSTART2 </div> <div style="display: flex; gap: 5px; margin-top: 5px;"> CPSTART3 CPSTART4 </div>	On completion of deceleration, the axis reverses its moving direction, returns to the preceding point at the absolute value of the specified speed, and stops (waits) there.
Speed control (I)	<div style="display: flex; gap: 5px;"> VF VR </div>	On completion of deceleration, the axis reverses its moving direction at the absolute value of the specified speed. The axis does not stop until a stop instruction is input.
Speed control (II)	<div style="display: flex; gap: 5px;"> VVF VVR </div>	
Speed/position switching control	<div style="display: flex; gap: 5px;"> VPF VPR VPSTART </div>	The axis cannot return. The speed change request is regarded as a normal speed change request. Warning (error code: 0991H) will occur and the axis will be controlled at the speed limit value.
Position follow-up control	<div style="border: 1px solid black; padding: 2px; display: inline-block;">PFSTART</div>	
Speed control with fixed position stop	<div style="display: flex; gap: 5px;"> PVF PVR </div>	
JOG operation		
High-speed oscillation	<div style="border: 1px solid black; padding: 2px; display: inline-block;">OSC</div>	
Home position return	<div style="border: 1px solid black; padding: 2px; display: inline-block;">ZERO</div>	A speed change cannot be made. Warning (error code: 09EDH) will occur.

■ Controls

- If a speed change is made to a negative speed, control is executed with the control mode during the start as indicated in the above table.
- The returning command speed is the absolute value of a new speed.
- When the axis is waiting at the return position.
 - Signal states

Signal name	Status
[St.1040] Start accept flag (R: M30080+n/Q: M2001+n)	ON (unchanged from before execution of CHGV instruction)
[St.1060] Positioning start complete (R: M32400+32n/Q: M2400+20n)	ON (unchanged from before execution of CHGV instruction)
[St.1061] Positioning complete (R: M32401+32n/Q: M2401+20n)	OFF
[St.1062] In-position (R: M32402+32n/Q: M2402+20n)	ON
[St.1063] Command in-position (R: M32403+32n/Q: M2403+20n)	OFF
[St.1049] Speed change "0" accepting flag (R: M30272+n/Q: M2240+n)	ON

- Make a speed change to a positive speed for a restart.
- Turn on the stop command to end the positioning.
- A negative speed change made again will be ignored.
- While the axis is reversion in the speed control mode
 - Make a speed change to a positive speed to change the travel direction again.
 - Turn ON the stop command to make a stop.
 - A speed change is made in the opposite direction if a negative speed change is made again.
- A speed change to a negative speed will not be made for the axis which set the stroke limit as invalid.

Operation error

An operation error will occur and a speed change will not be made if:

- The specified axis No. of (S1) is outside the range.
- (S2) is an indirectly specified device and its device No. is outside the range.

A warning will occur and a speed change will not be made if:

- The axis specified with (S1) was performing home position return (warning (error code: 09EDH)).
- A speed change to a negative speed was made for the axis which set the stroke limit as invalid (warning (error code: 09EFH)).

Point

If the speed change is executed for the axis specified with (S1) during deceleration, the speed change is ignored. An error will not occur in this case.

A warning will occur and the axis to be controlled at the speed limit value if:

- The absolute value of the speed specified with (S2) is greater than the speed limit value (warning (error code: 0991H)).

Point

If the absolute value of a negative new speed is higher than the speed specified with the servo program during continuous trajectory control, return control is exercised at the speed specified in the program (speed clamp control for a speed change during continuous trajectory control). At this time, an error will not occur.

Program example

■ Program which changes the positioning speed of axis 2

```
CHGV(K2, K10)
```

Return program which changes the positioning speed of axis 1 to a negative value

CHGV(K1, K-1000)

The following operation will be performed when a return request is made in continuous trajectory control.

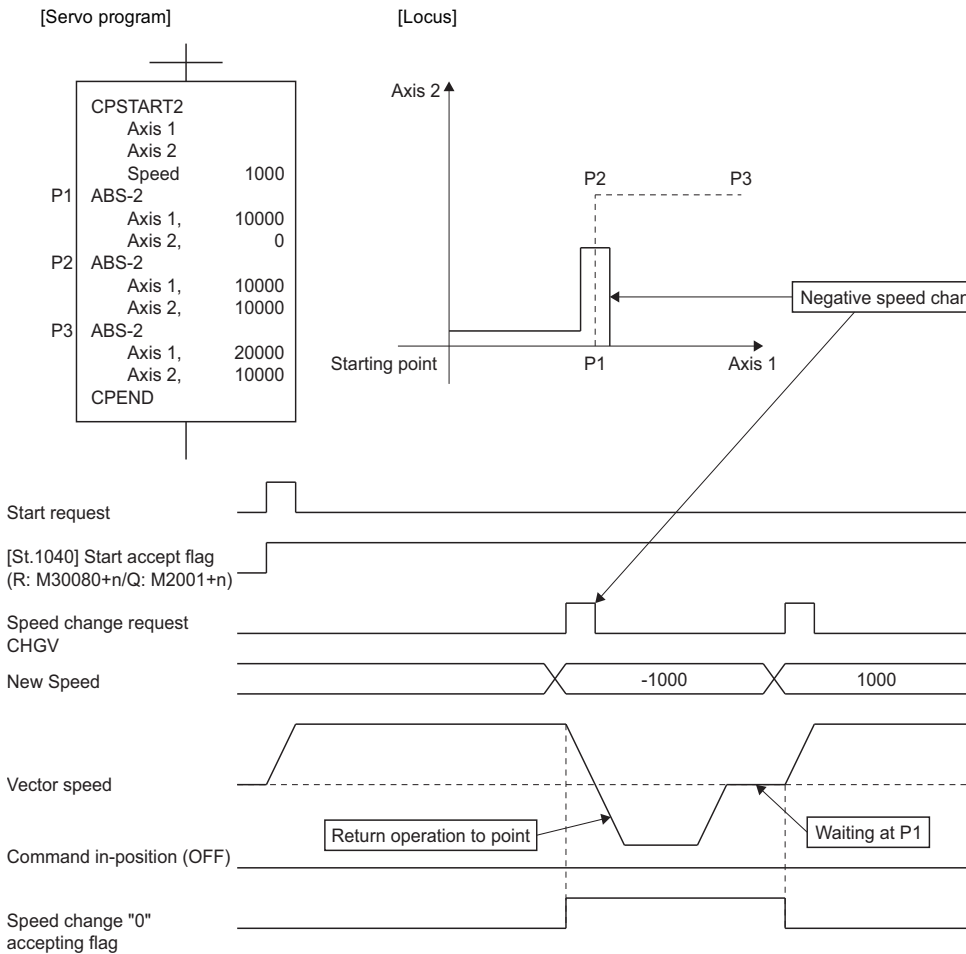

If a speed change to a negative speed is made during execution of positioning to P2 as shown above, the axis returns to P1 along the program specified locus and waits at P1.

Point

[Precautions at speed change]

- A speed change may be invalid if the speed change is executed until the "positioning start complete signal" status changes to ON at servo program start request. When making a speed change at almost the same timing as a start, create a program to execute speed change after the "positioning start complete signal" has turned on.
- When the reverse return is requested during stop in the state of FIN waiting using the M-code FIN signal wait function in continuous trajectory control, it will be ignored.
- In the example of previous page, if reverse return is requested before P2 and the axis passes through P2 during deceleration, it return to P2.
- There will be a delay of time equivalent to an operation cycle at the maximum in the response time from when the CHGV instruction is executed until the speed begins to change actually.

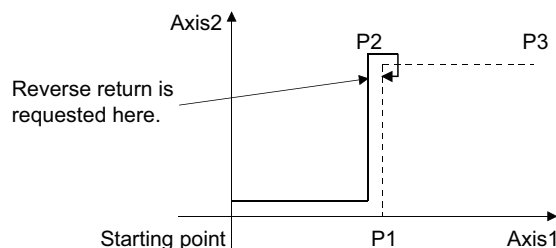

Command generation axis speed change request: CHGVS

Format	Number of basic steps	Usable steps	
		F/FS	G
CHGVS((S1), (S2))	7	○	○

Setting data

■ Usable Data

○: Usable

Setting data	Usable Data									
	Bit device	Word device			Constant			Calculation expression	Bit conditional expression	Comparison conditional expression
		16-bit integer type	32-bit integer type (L)	64-bit floating point type (F)	16-bit integer type (K/H)	32-bit integer type (K/H, L)	64-bit floating point type (K)			
(S1)	—	○	—	—	○	—	—	—	—	—
(S2)	—	○	○	—	○	○	—	○	—	—

■ Description, data type of result

Setting data	Description	Data type of result
(S1)	Axis No. to which speed change request will be given	—
(S2)	Specified speed	—

Processing details

• A speed change is made shown below.

1. The "[St.346] Command generation axis speed change accepting flag (R: M36751+32n/Q: M9811+20n)" corresponding to the axis specified with (S1) is turned ON.
 2. The speed of the axis specified with (S1) is changed to the speed specified with (S2).
 3. The speed change accepting flag is turned OFF.
- The axis No. that may be set at (S1) is within the following range.

Motion CPU	Setting range
R64MTCPU	1 to 64
R32MTCPU	1 to 32
R16MTCPU	1 to 16

• For interpolation control, set any one of the interpolation axes to (S1). When linear interpolation control is exercised, a speed change varies as described below with the positioning speed designation method set in the servo program.

Positioning speed designation method	Operation
Vector speed designation	Speed change is made so that the vector speed becomes the speed specified with (S2).
Longest axis designation	Speed change is made so that the longest axis speed becomes the speed specified with (S2).
Reference axis speed designation	Speed change is made so that the reference axis speed becomes the speed specified with (S2).



• Operation varies with the sign of the specified speed set at (S2).

Sign of specified speed	Operation
Positive	Speed change
0	Temporary stop
Negative	Return

- The specified speed that may be set at (S2) is within the following range.

Requested operation	Setting range			
	mm	inch	degree	pulse
Speed change request	0 to 600000000 ($\times 10^{-2}$ [mm/min])	0 to 600000000 ($\times 10^{-3}$ [inch/min])	0 to 2147483647 ($\times 10^{-3}$ [degree/min]) ^{*1}	0 to 2147483647 [pulse/s]
Return request	-1 to -600000000 ($\times 10^{-2}$ [mm/min])	-1 to -600000000 ($\times 10^{-3}$ [inch/min])	-1 to -2147483647 ($\times 10^{-3}$ [degree/min]) ^{*1}	-1 to -2147483647 [pulse/s]

*1 When the "speed control 10 × multiplier setting for degree axis" is set to "valid" in the fixed parameter, the unit is ($\times 10^{-2}$ [degree/min]).

- The speed changed by CHGVS instruction is effective only on the servo program during starting.
- The speed change does not executed for the axis specified with (S1) during deceleration stop.
- Acceleration/deceleration time at speed change can be changed by setting the acceleration/deceleration time change parameter of the axis specified by (S1). Refer to the following for acceleration/deceleration time change parameter.
 MELSEC iQ-R Motion controller Programming Manual (Advanced Synchronous Control) Refer to the following for acceleration/deceleration time change function.
 MELSEC iQ-R Motion controller Programming Manual (Positioning Control)
- By specifying a negative speed and making a speed change request during the start, allows the axis to start deceleration at that point and return in the opposite direction upon completion of deceleration. The following operations by the servo instruction are shown below.

Control mode	Servo instruction	Operation
Linear control	<div style="display: flex; gap: 5px;"> <div style="border: 1px solid black; padding: 2px;">ABS-1</div> <div style="border: 1px solid black; padding: 2px;">ABS-2</div> <div style="border: 1px solid black; padding: 2px;">ABS-3</div> <div style="border: 1px solid black; padding: 2px;">ABS-4</div> </div> <div style="display: flex; gap: 5px; margin-top: 5px;"> <div style="border: 1px solid black; padding: 2px;">INC-1</div> <div style="border: 1px solid black; padding: 2px;">INC-2</div> <div style="border: 1px solid black; padding: 2px;">INC-3</div> <div style="border: 1px solid black; padding: 2px;">INC-4</div> </div>	On completion of deceleration, the axis reverses its moving direction, returns to the positioning starting point at the absolute value of the specified speed, and stops (waits) there. For circular interpolation, the axis returns in the circular path.
Circular interpolation control	<div style="display: flex; gap: 5px;"> <div style="border: 1px solid black; padding: 2px;">ABS circular</div> <div style="border: 1px solid black; padding: 2px;">INC circular</div> </div>	
Fixed-pitch feed	<div style="display: flex; gap: 5px;"> <div style="border: 1px solid black; padding: 2px;">FEED-1</div> <div style="border: 1px solid black; padding: 2px;">FEED-2</div> <div style="border: 1px solid black; padding: 2px;">FEED-3</div> </div>	
Continuous trajectory control	<div style="display: flex; gap: 10px;"> <div style="border: 1px solid black; padding: 2px;">CPSTART1</div> <div style="border: 1px solid black; padding: 2px;">CPSTART2</div> </div> <div style="display: flex; gap: 10px; margin-top: 5px;"> <div style="border: 1px solid black; padding: 2px;">CPSTART3</div> <div style="border: 1px solid black; padding: 2px;">CPSTART4</div> </div>	On completion of deceleration, the axis reverses its moving direction, returns to the preceding point at the absolute value of the specified speed, and stops (waits) there.
Speed control (I)	<div style="display: flex; gap: 5px;"> <div style="border: 1px solid black; padding: 2px;">VF</div> <div style="border: 1px solid black; padding: 2px;">VR</div> </div>	On completion of deceleration, the axis reverses its moving direction at the absolute value of the specified speed. The axis does not stop until a stop instruction is input.
Position follow-up control	<div style="border: 1px solid black; padding: 2px;">PFSTART</div>	The axis cannot return. The speed change request is regarded as a normal speed change request.
Speed control with fixed position stop	<div style="display: flex; gap: 5px;"> <div style="border: 1px solid black; padding: 2px;">PVF</div> <div style="border: 1px solid black; padding: 2px;">PVR</div> </div>	Warning (error code: 0991H) will occur and the axis will be controlled at the speed limit value.
JOG operation		

■ Controls

- If a speed change is made to a negative speed, control is executed with the control mode during the start as indicated in the above table.
- The returning command speed is the absolute value of a new speed.
- When the axis is waiting at the return position.
 - Signal states

Signal name	Status
[St.345] Command generation axis start accept flag (R: M36750+32n/Q: M9810+20n)	ON (unchanged from before execution of CHGVS instruction)
[St.340] Command generation axis positioning start complete (R: M36560+32n/Q: M9800+20n)	ON (unchanged from before execution of CHGVS instruction)
[St.341] Command generation axis positioning complete (R: M36561+32n/Q: M9801+20n)	OFF
[St.342] Command generation axis command in-position (R: M36563+32n/Q: M9803+20n)	OFF
[St.347] Command generation axis speed change "0" accepting flag (R: M36572+32n/Q: M9812+20n)	ON

- Make a speed change to a positive speed for a restart.
- Turn on the stop command to end the positioning.
- A negative speed change made again will be ignored.
- While the axis is reversion in the speed control mode
 - Make a speed change to a positive speed to change the travel direction again.
 - Turn ON the stop command to make a stop.
 - A speed change is made in the opposite direction if a negative speed change is made again.
- A speed change to a negative speed will not be made for the axis which set the stroke limit as invalid.

Operation error

An operation error will occur and a speed change will not be made if:

- The specified axis No. of (S1) is outside the range.
- (S2) is an indirectly specified device and its device No. is outside the range.

A warning will occur and a speed change will not be made if:

- A speed change to a negative speed was made for the axis which set the stroke limit as invalid (warning (error code: 09EFH)).

Point

If the speed change is executed for the axis specified with (S1) during deceleration, the speed change is ignored. An error will not occur in this case.

A warning will occur and the axis to be controlled at the speed limit value if:

- The absolute value of the speed specified with (S2) is greater than the speed limit value (warning (error code: 0991H)).

Point

If the absolute value of a negative new speed is higher than the speed specified with the servo program during continuous trajectory control, return control is exercised at the speed specified in the program (speed clamp control for a speed change during continuous trajectory control). At this time, an error will not occur.

Program example

■ Program which changes the positioning speed of axis 2

```
CHGVS(K2, K10)
```

Point

[Precautions at speed change]

- A speed change may be invalid if the speed change is executed until the "positioning start complete signal" status changes to ON at servo program start request. When making a speed change at almost the same timing as a start, create a program to execute speed change after the "positioning start complete signal" has turned on.
- When the reverse return is requested during stop in the state of FIN waiting using the M-code FIN signal wait function in continuous trajectory control, it will be ignored.
- In the example of previous page, if reverse return is requested before P2 and the axis passes through P2 during deceleration, it return to P2.
- There will be a delay of time equivalent to an operation cycle at the maximum in the response time from when the CHGVS instruction is executed until the speed begins to change actually.

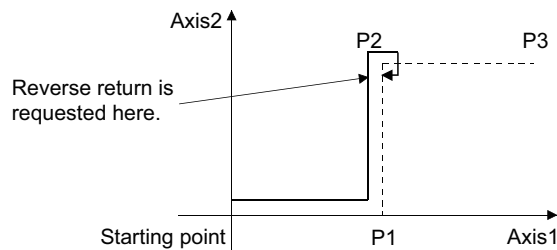

Torque limit value change request: CHGT

Format	Number of basic steps	Usable steps	
		F/FS	G
CHGT((S1), (S2), (S3))	10	○	○

Setting data

■ Usable Data

○: Usable

Setting data	Usable Data									
	Bit device	Word device			Constant			Calculation expression	Bit conditional expression	Comparison conditional expression
		16-bit integer type	32-bit integer type (L)	64-bit floating point type (F)	16-bit integer type (K/H)	32-bit integer type (K/H, L)	64-bit floating point type (K)			
(S1)	—	○	—	—	○	—	—	—	—	—
(S2)	—	○	○	—	○	○	—	○	—	—
(S3)	—	○	○	—	○	○	—	○	—	—

■ Description, data type of result

Setting data	Description	Data type of result
(S1)	Axis No. to which torque limit value change request will be given	—
(S2)	Positive direction torque limit value ($\times 0.1\%$)	
(S3)	Negative direction torque limit value ($\times 0.1\%$)	

Processing details

- The torque limit value of the axis specified with (S1) is changed to the positive direction torque limit value specified with (S2) and negative direction torque limit value specified with (S3). The positive direction torque limit value restricts the forward rotation (CCW) driving torque and reverse rotation (CW) regenerative torque of the servo motor, and negative direction torque limit value restricts the reverse rotation (CW) driving torque and forward rotation (CCW) regenerative torque of the servo motor.
- Any axis that has completed a servo startup can be changed in torque limit value any time, independently of the status, starting, stopping, servo ON or servo OFF.
- The axis No. that may be set at (S1) is shown below.

Motion CPU	Setting range
R64MTCPU	1 to 64
R32MTCPU	1 to 32
R16MTCPU	1 to 16

- (S2) and (S3) cannot be omitted. When only either torque limit value is changed, set "-1" as the setting data not to change.
- The torque limit value that may be set at (S2) and (S3) is within the range 1 to 10000 ($\times 0.1\%$).
- During speed-torque control, do not change the torque limit value to higher value than torque limit value in speed-torque control set in the speed-torque control data of servo data setting. If the either value of (S2) or (S3) specified with CHGT instruction is higher than torque limit value in speed-torque control, a warning (error code: 0A5EH) will occur, and the individual change of torque limit value is not executed.
- The positive direction torque limit value and negative direction torque limit value can be monitored by setting the positive direction torque limit value monitor device and negative direction torque limit value monitor device in the expansion parameter of servo data setting.

Operation error

An operation error will occur and a torque limit value change will not be made if:

- The specified axis No. at (S1) is outside the range.
- (S2) or (S3) is an indirectly specified device and its device No. is outside the range.

A warning will occur and a torque limit value change will not be made if:

- The torque limit value specified with (S2) or (S3) is outside the range of 0.1 to 1000.0[%] (warning (error code: 0A5BH)).
- The CHGT instruction is executed for any axis that has not yet been started (warning (error code: 0A5CH)).
- When the CHGT instruction is executed for any axis during speed-torque control, the value of (S2) or (S3) is greater than the torque limit value in speed-torque control (warning (error code: 0A5EH)).

Program example

■ **Program which changes the torque limit value of axis 2 to positive direction 20.0[%] and to negative direction 10.0[%]**

```
CHGT(K2, K200, K100)
```

Point

There will be a delay of time equivalent to an operation cycle at the maximum in the time from when the CHGT instruction is executed until the torque limit value is transferred to servo amplifier actually.

Target position change request: CHGP

Format	Number of basic steps	Usable steps	
		F/FS	G
CHGP((S1), (S2), (S3))	11	○	○

Setting data

■ Usable Data

○: Usable

Setting data	Usable Data									
	Bit device	Word device			Constant			Calculation expression	Bit conditional expression	Comparison conditional expression
		16-bit integer type	32-bit integer type (L)	64-bit floating point type (F)	16-bit integer type (K/H)	32-bit integer type (K/H, L)	64-bit floating point type (K)			
(S1)	—	○	—	—	○	—	—	—	—	—
(S2)	—	○	—	—	○	—	—	—	—	—
(S3)	—	○	—	—	—	—	—	—	—	—

■ Description, data type of result

Setting data	Description	Data type of result
(S1)	Axis No. to which target position change request will be given	—
(S2)	Specified method of changed address 0: Address method 1: Movement method	
(S3)	Starting No. of device to store target position change value	



The CHGP instruction cannot be used for the command generation axis under advanced synchronous control.

Processing details

- The target position is changed during positioning instruction execution by target position change request. New target position can be set by the absolute address or relative movement amount from feed current value at target position change request. Operation for executing target position change request to $(X, Y) = (400.0\mu\text{m}, 500.0\mu\text{m})$ by absolute address setting during linear interpolation control from positioning start position $(X, Y) = (0.0\mu\text{m}, 0.0\mu\text{m})$ to $(X, Y) = (800.0\mu\text{m}, 600.0\mu\text{m})$ is shown below.

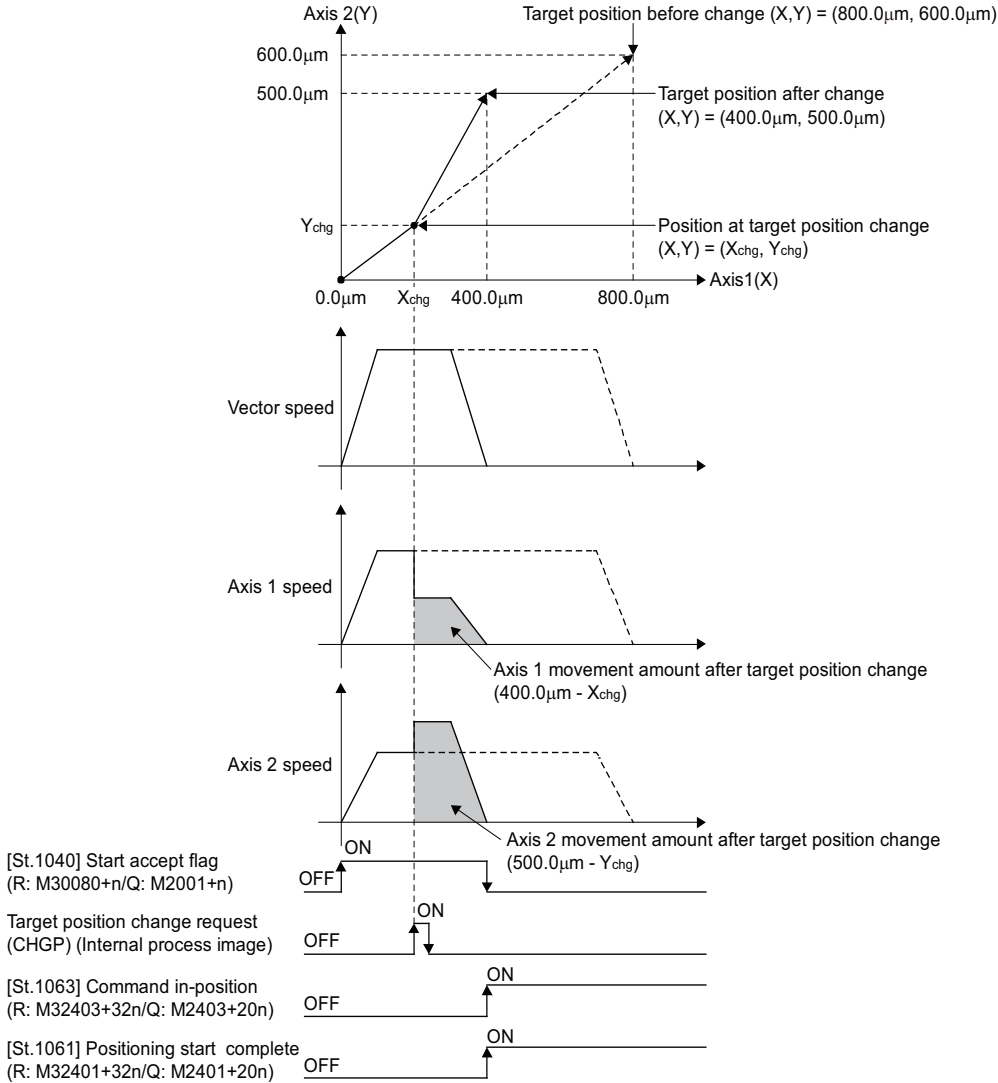

- The target position of the axis specified with (S1) is changed. The new target position is calculated by a value stored in the device specified with (S3) using the method specified with (S2).

Point

- CHGP instruction is enabled to only starting axis.
- The target position is not changed when the specified axis is during deceleration stop.
- There will be a delay of time equivalent to an operation cycle at the maximum from when the CHGP instruction is executed until the target position is changed actually.
- When the CHGP instruction is executed at servo program start request ("[St.1060] Positioning start complete (R: M32400+32n/Q: M2400+20n)" is OFF), the target position change becomes disabled. Create the program to execute the target position change after positioning start complete signal ON to change the target position at same timing with servo program start.

- The axis No. that may be set at (S1) is within the following range. For interpolation control, set any one of the interpolation axes to (S1).

Motion CPU	Setting range
R64MTCPU	1 to 64
R32MTCPU	1 to 32
R16MTCPU	1 to 16

- The target position by setting of (S2) is shown below.
- When "0" (address method) is set to (S2), the target position is the target position change value stored in the device specified with (S3).
- When "1" (movement method) is set to (S2), the target position is the position that the movement for target position change value stored in the device specified with (S3) is executed from the feed current value at CHGP instruction execution.

Point

When "1" (movement method) is set to (S2) and the CHGP instruction is executed with a normal task, a dispersion may occur for new target position depending on a dispersion of instruction accept timing. Execute the CHGP instruction in the fixed cycle task same as operation cycle to inhibit a dispersion.

- Set the starting device No. to store a target position change value at (S3). Set an even number as first device, and set a target position change value as follows.

Offset	Name	Setting range				
		mm	inch	pulse	degree	
					Address method	Movement method
+0	Target position change value 1	-2147483648 to 2147483647 ($\times 10^{-1}$ [μm])	-2147483648 to 2147483647 ($\times 10^{-5}$ [inch])	-2147483648 to 2147483647 ([pulse])	0 to 35999999 ($\times 10^{-5}$ [degree])	-2147483648 to 2147483647 ($\times 10^{-5}$ [degree])
+1						
+2	Target position change value 2					
+3						
+4	Target position change value 3					
+5						
+6	Target position change value 4					
+7						

- Set the positioning address and movement amount according to the setting of (S2) for target position change value.
- Set the axis No. among interpolation axes in ascending order for target position change value.

Ex.

When the target position change request is executed during INC-3 instruction execution.

[K100]	INC-3
Axis	3, 3000 pulse
Axis	4, 4000 pulse
Axis	1, 4000 pulse
Speed	10000 pulse/s

The axis No. for target position change value 1 to 4 are as follows.

- Target position change value 1: Setting of axis No.1
- Target position change value 2: Setting of axis No.3
- Target position change value 3: Setting of axis No.4
- Target position change value 4: Not necessary to set

- The following operations by the servo instruction at CHGP instruction execution are shown below.

Control mode	Servo instruction	Operation
Linear control	ABS-1 ABS-2 ABS-3 ABS-4 INC-1 INC-2 INC-3 INC-4	The positioning is executed from current feed value during execution to new target position with linear interpolation control.
Fixed-pitch feed	FEED-1 FEED-2 FEED-3	
Circular interpolation control	ABS circular INC circular	The target position change is ignored, and a warning (error code: 099BH) will occur.
Helical interpolation control	ABS helical INC helical	
Continuous trajectory control	CPSTART1 CPSTART2 CPSTART3 CPSTART4	The positioning is executed from current feed value during execution to new target position with linear interpolation control. The positioning to a remaining point is not executed.
Speed control (I)	VF VR	The target position change is ignored, and a warning (error code: 099BH) will occur.
Speed control (II)	VVF VVR	
Speed/position switching control	VPF VPR VPSTART	
Position follow-up control	PFSTART	
Speed control with fixed position stop	PVF PVR	
JOG operation		
Speed-torque control		
Pressure control		
High-speed oscillation	OSC	
Home position return	ZERO	
Machine control		The target position change is ignored.

- Operation after execution of CHGP instruction are as follows.
 - "[St.1048] Automatic decelerating flag (R: M30208+n/Q: M2128+n)" turns ON with automatic deceleration processing to new target position.
 - "[St.1063] Command in-position (R: M32403+32n/Q: M2403+20n)" turns ON when the absolute value of difference between new target position and current feed value becomes "command in-position range" or less.
 - "[St.1061] Positioning complete (R: M32401+32n/Q: M2401+20n)" turns ON with command output completion to new target position.
- After execution of CHGP instruction, the vector speed does not change, but each axis speed changes according to new target position. Therefore, each axis speed may change rapidly depending on new target position.
- When the reference axis speed designation or longest axis reference designation is set in the linear interpolation control, an operation is as follows.
 - The longest axis is not selected again at target position change. The longest axis before change is used continuously.
 - The positioning speed is calculated depending on the movement amount for each axis new target position.
 - When the movement amount of reference axis or longest axis depending on the target position change becomes 0, a minor error (error code: 1A5FH) will occur and deceleration stop is executed.

- The positioning is executed to new target position with CHGP instruction during continuous trajectory control. The positioning to a point since executing point at target position change request is not executed.

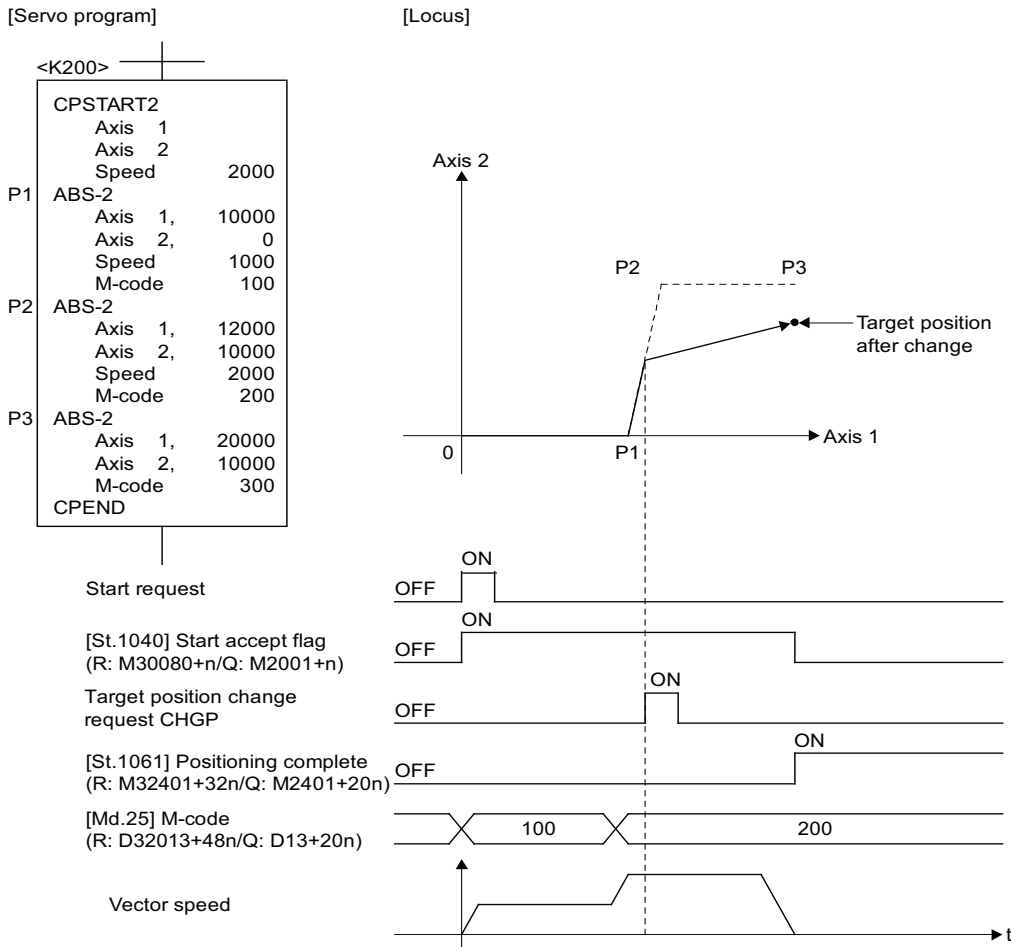

Point

- The positioning is executed with the setting items of executing point for CHGP instruction.
- The linear interpolation control is executed in all axes specified with CPSTART for CHGP instruction. Set target position for all axes specified with CPSTART.
- When the CHGP instruction is executed during positioning to a point of circular interpolation or helical interpolation in the continuous trajectory control, the target position change is executed at the same time of positioning to a point of linear interpolation.

- When the target position change of address method to the axis of control unit [degree] is executed, operation is as follows.
 - The positioning to new address is executed in the current direction.
 - Set "0 to 35999999×10^{-5} [degree] as new address at the address method. If the outside of range is set, a minor error (error code: 1A5CH) will occur and deceleration stop is executed.

- Operation for the movement amount to new target position is less than deceleration distance required to deceleration stop from speed during control by execution of CHGP instruction is as follows.
- A minor error (error code: 1A5DH) will occur and deceleration stop is executed at execution of CHGP instruction.
- The difference between movement amount to the deceleration stop and movement amount to new target position is overrun.
- The "[St.1061] Positioning complete (R: M32401+32n/Q: M2401+20n)" does not turn ON.

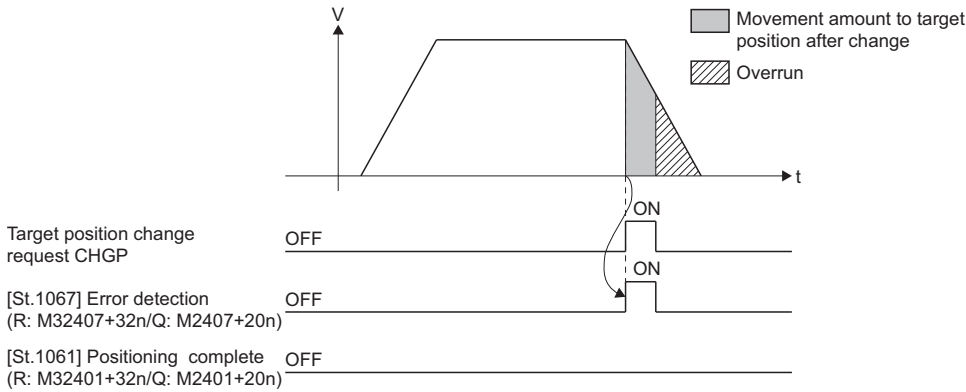

- When the negative speed change is executed after execution of CHGP instruction, a deceleration is executed to speed 0. Then, it returns to position at target position change (CHGP instruction accept), and stops (waits) there.

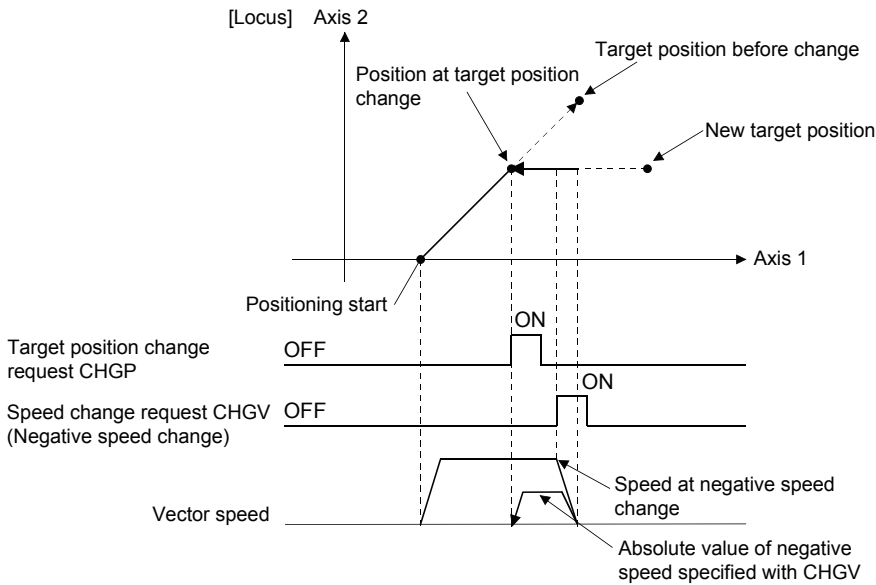

Operation error

An operation error will occur and a target position change will not be made if:

- The specified axis No. at (S1) is outside the range.
- Except 0 to 1 is set at (S2).
- (S3) is not an even-numbered device.
- The device No. (S3) to (S3) +7 is outside the range.

A warning or minor error will occur and a target position change will not be made if:

- During home position return for target axis (warning (error code: 099BH)).
- During execution of servo program that does not correspond with the target position change for target axis (warning (error code: 099BH)).
- New target position exceeded the stroke limit range (minor error (error code: 1A5EH)).
- FIN acceleration/deceleration or advanced S-curve acceleration/deceleration as acceleration/deceleration method is set (minor error (error code: 19E6H)).
- When the reference axis speed designation or longest axis designation is set in the linear interpolation control, the movement amount for reference axis or longest axis after target position change becomes 0 (minor error (error code: 1A5FH)).
- When the target position change of address method to the axis of control unit [degree] is executed, new address is outside the range of 0 to 35999999×10^{-5} [degree] (minor error (error code: 1A5CH)).
- The movement amount to new target position is less than deceleration distance required to deceleration stop from speed during control (minor error (error code: 1A5DH)).

Program example

■ Program which executes the target position change by movement method to axis 2 and axis 8 during positioning by ABS-2

[Servo program]

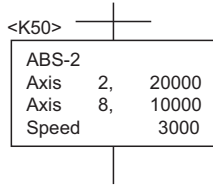

[Motion SFC program]

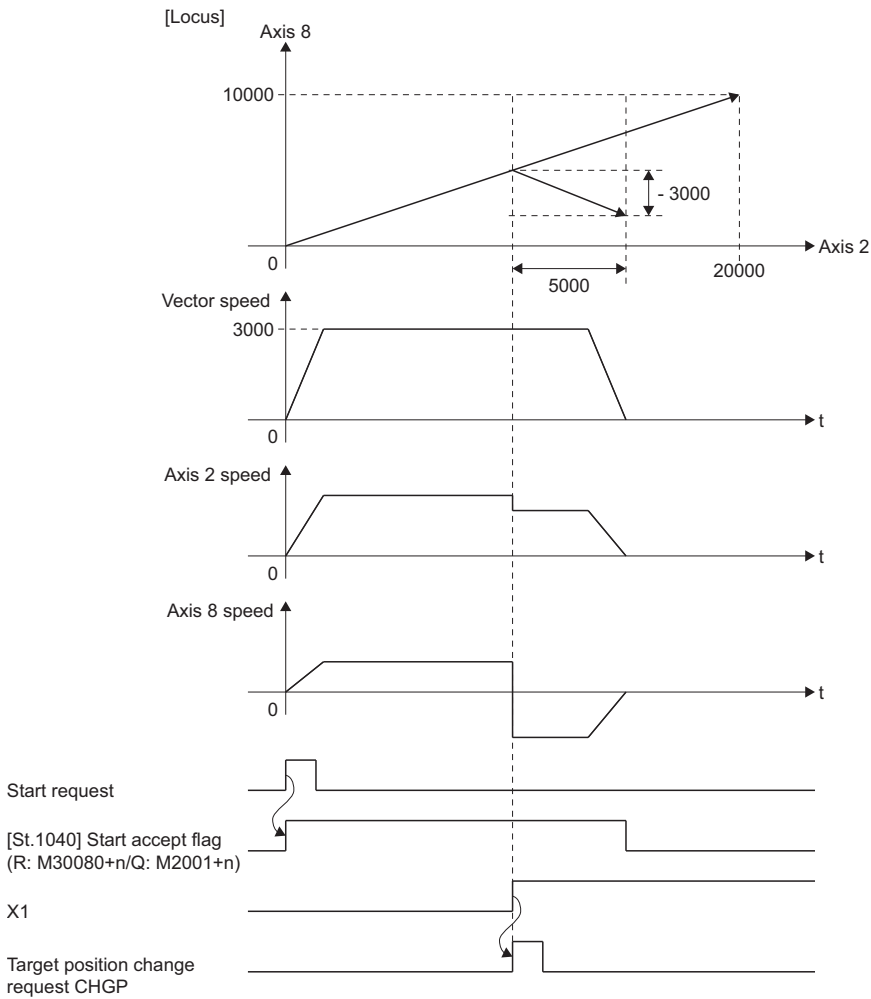
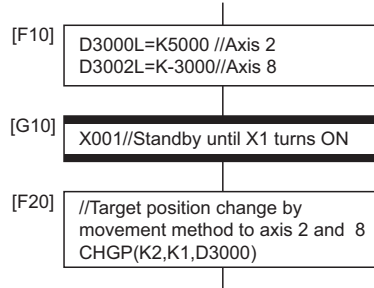

Machine program operation start request: MCNST

Format	Number of basic steps	Usable steps	
		F/FS	G
MCNST((S1), (S2))	7	○	○

Setting data

■ Usable Data

○: Usable

Setting data	Usable Data									
	Bit device	Word device			Constant			Calculation expression	Bit conditional expression	Comparison conditional expression
		16-bit integer type	32-bit integer type (L)	64-bit floating point type (F)	16-bit integer type (K/H)	32-bit integer type (K/H, L)	64-bit floating point type (K)			
(S1)	—	○	—	—	—	—	—	—	—	—
(S2)	—	○	—	—	○	—	—	○	—	—

■ Description, data type of result

Setting data	Description	Data type of result
(S1)	Starting No. of device where machine positioning data is stored.	—
(S2)	Size (words) of machine positioning data area (78 to 10820)* ¹	—

*1 For operating system software version "09" or earlier, 78 to 5444.

Processing details

- Machine program operation start request is performed for the machine positioning data from the starting No. specified with (S1), for an area size specified with (S2).
- Refer to the following for machine positioning data stored in the device specified with (S1).
 MELSEC iQ-R Motion Controller Programming Manual (Machine Control)
- The machine positioning data that may be set at (S2) is within the range 78 to 10820 (for operating system software version "09" or earlier, 78 to 5444).

Operation error

An operation error will occur and a machine program operation start request will not be made if:

- (S1) is not an even-numbered device. (Details code: 1)
- The device No. of (S1)+(S2) is outside the range. (Details code: 2)
- Instruction area for MCNST instruction is not enough. (9 or more instructions operate in the Motion dedicated PLC instruction (M(P).MCNST/D(P).MCNST) and Motion dedicated function (MCNST))(Details code: 3)
- Machine positioning data area settings are wrong. (Details code: 4)
- The points set to the data area in (S2) are not inside the range of 78 to 10820 (for operating system software version "09" or earlier, 78 to 5444). (Details code: 4)
- There is an excess/deficiency in the data area points for the area calculated from the number of points for every point. (Details code: 4)
- The number of positioning points is outside the range of 1 to 256 (for operating system software version "09" or earlier, 1 to 128). (Details code: 4)
- The control method specified by machine positioning data is wrong. (includes when the control method for every point is NOP only) (Details code: 5)
- The machine No. specified by machine positioning data is outside of range. (Details code: 6)

Program example

- Program for machine program operation start request which performs linear interpolation to positioning point P100 at a command speed of 10000 for the machine 1 that consists of axis 1 and axis 2.

```
MCNST(D2000,K78)
```

```
[F10] //Set machine positioning data 1
      //Number of points, Machine No.
      D2000=K1 // Number of positioning points(1)
      D2001=K1 // Machine No.

[F11] //Set machine positioning data 2
      //Data items for positioning(common)
      D2002L=H0L // Data items setting for positioning(all disabled)
      FMOV D2004,K0,K32 // Expansion point items setting value
                   (For 32 words)(Not used(0))

[F12] //Set data for positioning point (1)
      #0=H0100 // Control method(linear interpolation (ABS))
      #1=K0 // Specify positioning point(world coordinate system)
      #2L=K10000L // Command speed=100.00[mm/min]
      #4=K100 // Point block No.(P100)
      #5=K0 // Auxiliary/central point block data(Not used(0))
      #6L=K0L // Radius(Not used(0))
      #8=K0 // Expansion point item setting(all disabled)
      #9=K0 // Empty (0)
      FMOV #10,K0,K32 // Expansion point items setting value
                   (For 32 words)(Not used(0))
      BMOV D2036,#0,K42 // Batch transmit 42 words from #0 to
                   positioning point (1)

[G10] !M43911 // Wait for machine No.1 start accept flag OFF

[F13] MCNST(D2000,K78) // Machine program operation start request
```

4.16 Advanced Synchronous Control Dedicated Function

Cam data read: CAMRD

Format	Number of basic steps	Usable steps	
		F/FS	G
CAMRD (S1), (S2), (n), (D), (S3)	16	○	○

Setting data

■ Usable data

○: Usable

Setting data	Usable Data									
	Bit device	Word device			Constant			Calculation expression	Bit conditional expression	Comparison conditional expression
		16-bit integer type	32-bit integer type (L)	64-bit floating point type (F)	16-bit integer type (K/H)	32-bit integer type (K/H, L)	64-bit floating point type (K)			
(S1)	—	○	—	—	○	—	—	—	—	—
(S2)	—	○	○	—	○	○	—	○	—	—
(n)	—	○	○	—	○	○	—	○	—	—
(D)	—	○	—	—	—	—	—	—	—	—
(S3)	—	○	—	—	○	—	—	—	—	—

■ Description, data type of result

Setting data	Description	Data type of result
(S1)	Cam No. (1 to 1024)	—
(S2)	Cam data first position Stroke ratio data format: 1 to cam resolution Coordinate data format: 0 to (Coordinate number-1) Auto-generation data format: 0	
(n)	Number of cam data points Stroke ratio data format: 1 to 32768 Coordinate data format: 1 to 16384 Auto-generation data format: 0	
(D)	Start device No. which stores the reading cam data	
(S3)	Call source 0: Built-in memory of the cam open area (default value) 2: Cam file on the SD memory card 4: Cam file on the standard ROM	

Processing details

- Of the cam No. data specified with (S1), the (S3) cam data of the (n) number of points, starting from the position specified with (S2), is read. The read cam data is stored in the device specified with (D) or later. However, (S2) and (n) are ignored when an auto-generation format cam is read.
- Set the cam data first position specified with (S2) within the following range.

Data format	First position range
Stroke ratio data format	1 to cam resolution*1
Coordinate data format	0 to (Coordinate number-1)

*1 Since the stroke ratio of the zeroth point cam data is fixed at 0%, the cam data cannot be read.

- Specify the number of read points for (n). Specify the number of read points so that the device No. storing the end point data is within the range. The following shows the operation when the number of read points, starting from the first position, is outside the cam data range.

Data format	Operation
Stroke ratio data format	If the value calculated from "(S2) + (n) - 1" is larger than the cam resolution, the cam data, ranging from the cam data first position to the cam resolution, is read.
Coordinate data format	If the value calculated from "(S2) + (n)" is larger than the number of coordinates, the cam data, ranging from the cam data first position to the last coordinate, is read.

- The device No. specified with (D) should be an even number. The read cam data is stored in the specified device according to the cam data format as follows.

■Stroke ratio data format

Offset	Item	Range
+0	Can data format (Stroke ratio data format)	1
+1	Cam data starting point	0 to (Coordinate resolution-1)
+2	Cam resolution	256/512/1024/2048/4096/8192/16384/32768
+3		
+4	Stroke ratio at first point cam data value	-2147483648 to 2147483647[$\times 10^{-7}$ %] (-214.7483648 to 214.7483647[%])
+5		
+6	Stroke ratio at second point cam data value	
+7		
⋮	⋮	
+(2N+2)	Stroke ratio at Nth point cam data value	
+(2N+3)		

Coordinate data format



Offset	Item	Range
+0	Can data format (Coordinate data format)	2
+1	Unusable	0
+2	Coordinate number	2 to 65535
+3		
+4	At first point cam data value	Input value X_1
+5		
+6		-2147483648 to 2147483647 [Output axis position unit]
+7		
+8	At second point cam data value	Input value X_2
+9		
+10		-2147483648 to 2147483647 [Output axis position unit]
+11		
⋮	⋮	⋮
+ (4N)	At Nth point cam data value	Input value X_N
+ (4N+1)		
+ (4N+2)		-2147483648 to 2147483647 [Output axis position unit]
+ (4N+3)		

Point

For coordinate data format, when reading is not completed in one attempt, divide the reading over several attempts.

Auto-generation data format

Executes the CAMRD instruction for cam files created by the CAMMK instruction, or cam files created by the cam curves in MT Developer2, and reads as auto-generation data format.

- Cam for rotary cutter ( Page 234 Device assignment of the cam auto-generation data for the rotary cutter cam)
- Easy stroke ratio cam, Advanced stroke ratio cam ( Page 236 Device assignment of the cam auto-generation data)

Point

- Cam file created by the cam curves in MT Developer2 is read as data for auto-generation of the advanced stroke ratio cam.
- When cam data for a cam curve created by the cam curves in MT Developer2 is read by the CAMRD instruction, it is read to the specified device as data for auto-generation of the advanced stroke ratio cam with the cam type of all sections as "constant speed".

- Set a call source to (S3). The cam data is read from the cam file, for setting other than "0".

Setting value	Call source
0	Built-in memory of the cam open area
2	Cam file on the SD memory card
4	Cam file on the standard ROM

- When the call source specified by (S3) is other than "0: Built-in memory of the cam open area", "Cam data operation flag (SM505)" turns ON during the reading of cam data from the cam file, and turns OFF when reading ends. Check that "Cam data operation flag (SM505)" OFF is an interlock condition. When a CAMMK, CAMWR, CAMRD instruction for the cam file is executed while "Cam data operation flag (SM505)" is ON, an error occurs.
- (S3) can be omitted. The call source when (S3) is omitted is "0: Built-in memory of the cam open area"

Operation error

An operation error will occur, and the cam data read will not be executed if:

- Cam No. specified with (S1) is outside the range of 1 to 1024. (Details code: 1)
- The cam No. data specified with (S1) does not exist in the place specified with (S3). (Details code: 2)
- For cam data in the stroke ratio data format, the cam data first position specified with (S2) is outside the range of 1 to the cam resolution. (Details code: 3)
- For cam data in the coordinate data format, the cam data first position specified with (S2) is outside the range of 0 to (coordinate number - 1). (Details code: 3)
- For cam data in the stroke ratio data format, the number of cam data points is outside the range of 1 to 32768. (Details code: 4)
- For cam data in the coordinate data format, the number of cam data points is outside the range of 1 to 16384. (Details code: 4)
- The device numbers storing the number of cam data points specified with (n) are outside the range. (Details code: 5)
- (D) is not an even-numbered device. (Details code: 6)
- The cam data was read with a cam file with "Read protection" file password set. (Details code: 7)
- A setting other than "0" was set while "Cam data operation flag (SM505)" is ON. (Details code: 8)
- The CAMRD instruction was executed for a cam file created by a free-form curve. (Details code: 9)
- The CAMRD instruction was executed for a cam change data cam file. (Details code: 18)
- An error occurred during cam file access. (Details code: 19)

Program example

- Program which reads 2048-points of data, starting from the first point cam data of cam No. 2 (stroke ratio data format), and stores the read data to #0 to #4099

```
CAMRD K2, K1, K2048, #0
```

- Program which reads 6-points of data, starting from the zeroth point cam data of cam No.1 (coordinate data format), and stores the read data to #100 to #127

```
CAMRD K1, K0, K6, #100
```

- Cam data No.1

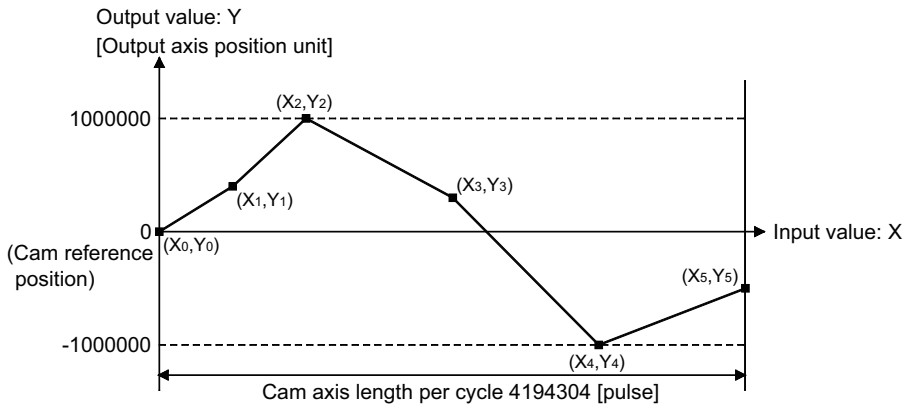

- Read cam data

```
#100=K2 //Coordinate data format
#102L=K6 //Number of coordinates 6
#104L=K0 //(1st point) input value
#106L=K0 //(1st point) output value
#108L=K524288 //(2nd point) input value
#110L=K400000 //(2nd point) output value
#112L=K1048576 //(3rd point) input value
#114L=K1000000 //(3rd point) output value
#116L=K2097152 //(4th point) input value
#118L=K300000 //(4th point) output value
#120L=K3145728 //(5th point) input value
#122L=K-1000000 //(5th point) output value
#124L=K4194304 //(6th point) input value
#126L=K-500000 //(6th point) output value
```

- Program which reads 2048-points of data, starting from the first point cam data of cam No.900 (coordinate data format) in the SD memory card, and stores the read data to #0 to #4099

```
CAMRD K900, K0, K2048, #0, K2
```

Cam data write: CAMWR

Format	Number of basic steps	Usable steps	
		F/FS	G
CAMWR (S1), (S2), (n), (S3), (D)	16	○	○

Setting data

■ Usable data

○: Usable

Setting data	Usable Data									
	Bit device	Word device			Constant			Calculation expression	Bit conditional expression	Comparison conditional expression
		16-bit integer type	32-bit integer type (L)	64-bit floating point type (F)	16-bit integer type (K/H)	32-bit integer type (K/H, L)	64-bit floating point type (K)			
(S1)	—	○	—	—	○	—	—	—	—	—
(S2)	—	○	○	—	○	○	—	○	—	—
(n)	—	○	○	—	○	○	—	○	—	—
(S3)	—	○	—	—	—	—	—	—	—	—
(D)	—	○	—	—	○	—	—	—	—	—

■ Description, data type of result

Setting data	Description	Data type of result
(S1)	Cam No. (1 to 1024)	—
(S2)	Cam data first position Stroke ratio data format: 1 to cam resolution Coordinate data format: 0 to (Coordinate number-1)	—
(n)	Number of cam data points Stroke ratio data format: 1 to 32768 Coordinate data format: 1 to 16384	—
(S3)	Start device No. which stores the writing cam data	—
(D)	Cam file write destination (0000H to 0401H)	—

Processing details

- Of the cam data (stroke ratio data format, or coordinate data format) stored in the device specified with (S3) or later, the data of the (n) number of points, starting from the cam data position specified with (S2), is written to the cam open area and the write destination of the cam file specified with (D).
- Set the cam data first position specified with (S2) within the following range.

Data format	First position range
Stroke ratio data format	1 to cam resolution ^{*1}
Coordinate data format	0 to (Coordinate number-1)

*1 Since the stroke ratio of the zeroth point cam data is fixed at 0%, the cam data cannot be write.

- For (n), specify the number of write points, starting from the cam data first position specified with (S2). Specify the number of write points so that the device No. storing the end point data is within the range. If the number of write points, starting from the first position, is outside the cam data range, an operation error occurs and the data is not written.
- The device No. specified with (S3) should be an even number. The write cam data is stored in the specified device according to the cam data format as follows.

■Stroke ratio data format

Offset	Item	Range
+0	Can data format (Stroke ratio data format)	1
+1	Cam data starting point	0 to (Coordinate resolution-1)
+2	Cam resolution	256/512/1024/2048/4096/8192/16384/32768
+3		
+4	Stroke ratio at first point cam data value	-2147483648 to 2147483647[$\times 10^{-7}\%$] (-214.7483648 to 214.7483647[%])
+5		
+6	Stroke ratio at second point cam data value	
+7		
⋮	⋮	
+(2N+2)	Stroke ratio at Nth point cam data value	
+(2N+3)		

■Coordinate data format

Offset	Item	Range	
+0	Can data format (Coordinate data format)	2	
+1	Unusable	0	
+2	Coordinate number	2 to 65535	
+3			
+4	At first point cam data value	Input value X_1	0 to 2147483647 [Cam axis cycle unit]
+5		Output value Y_1	-2147483648 to 2147483647 [Output axis position unit]
+6			
+7			
+8	At second point cam data value	Input value X_2	0 to 2147483647 [Cam axis cycle unit]
+9		Output value Y_2	-2147483648 to 2147483647 [Output axis position unit]
+10			
+11			
⋮	⋮		⋮
+(4N)	At Nth point cam data value	Input value X_N	0 to 2147483647 [Cam axis cycle unit]
+(4N+1)		Output value Y_N	-2147483648 to 2147483647 [Output axis position unit]
+(4N+2)			
+(4N+3)			

Point

For coordinate data format, when writing is not completed in one attempt, divide the writing over several attempts.

- During the execution of the CAMWR instruction, another CAMWR instruction, or CAMMK instruction cannot be processed. During the execution of the CAMWR instruction, the "Cam data operation flag (SM505)" turns on. Therefore, create an interlock. When the CAMWR instruction, or CAMMK instruction is executed while the "Cam data operation flag (SM505)" is on, an error occurs.

Point

The CAMWR instruction can be executed during the synchronous control. Note that the contents of the cam data in operation are changed depending on the instruction execution timing.

- Set the write to cam file, and the cam file write destination to (D).

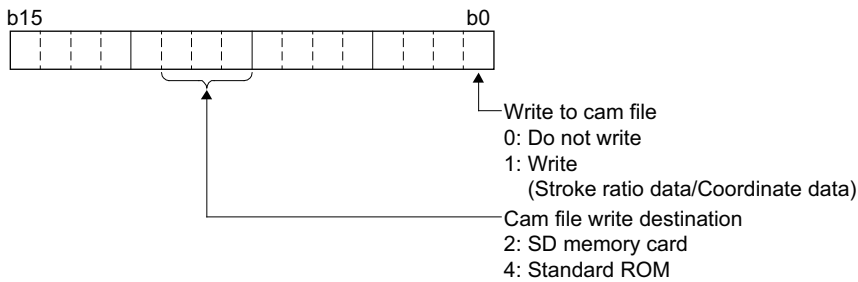

- (D) can be omitted. When (D) is omitted, or is set outside the range, cam data is written to the cam open area only. When performing write to cam file, set (D).

Point

When "1: Write" is set to the write to cam file in (D), write to cam file is performed after completion of write to the cam open area. When an error occurred during cam file operation, the cam data of the cam open area is held.

- The following shows the operation for when the cam No. specified by (S1) already exists in the cam open area.
 - When the cam data format, and resolution/number of coordinates are the same, the existing cam data is overwritten.
 - When the cam data format, or resolution/number of coordinates are different, the existing cam data is erased. (When the points of cam data are low due to resolution/number of coordinates, the cam data for sections where write was not performed become unfixed.)

Operation error

An operation error will occur, and the cam data write will not be executed if:

- Cam No. specified with (S1) is outside the range of 1 to 1024. (Details code: 1)
- For cam data in the stroke ratio data format, the cam data first position specified with (S2) is outside the range of 1 to the cam resolution. (Details code: 2)
- For cam data in the coordinate data format, the cam data first position specified with (S2) is outside the range of 0 to (coordinate number - 1). (Details code: 2)
- For cam data in the stroke ratio data format, the number of cam data points is outside the range of 1 to 32768 (Details code: 3).
- For cam data in the coordinate data format, the number of cam data points is outside the range of 1 to 16384. (Details code: 3)
- The start position and the number of cam data points, which are outside the range of the cam resolution or the number of coordinates, are set. (Details code: 3)
- The device numbers storing the number of cam data points specified with (n) are outside the range. (Details code: 4)
- (S3) is not an even-numbered device. (Details code: 5)
- Cam data format specified with (S3) is set to other than 1 or 2. (Details code: 6)
- For cam data in the stroke ratio data format, the cam resolution is set a value other than "256/512/1024/2048/4096/8192/16384/32768". (Details code: 7)
- For cam data in the coordinate data format, the coordinate number is set a value other than "2 to 65535". (Details code: 7)
- For cam data in the stroke ratio data format, the cam data first position is outside the range of 0 to (cam resolution - 1). (Details code: 8)
- The writable area is insufficient when the cam data is being written. (Details code: 10)
- The input value of the coordinate data is a negative value. (Details code: 11)
- The input value of the coordinate data satisfies " $X_n > X_{n+1}$ ". (Details code: 11)
- The CAMWR instruction is executed while the "Cam data operation flag (SM505)" is ON. (Details code: 13)

In the following cases an operation error occurs, and the write to cam file is not performed. (Write to the cam open area is performed)

- The CAMWR instruction was executed for a cam change data cam file. (Details code: 18)
- An error occurred during cam file access. (Details code: 19)

Program example

- Program which writes the data stored in #0 to #4099 to the 2048-point area, starting from the first point cam data, of cam No. 256 (stroke ratio data format)

```
CAMWR K256, K1, K2048, #0
```

- Program (Cam axis length per cycle = 4194304) which writes the data stored in #0 to #27 to the 6-point area, starting from the zeroth point cam data, of cam No. 255 (coordinate data format)

```
#0=K2 //Coordinate data format
#2L=K6 //Number of coordinates 6
#4L=K0 //(1st point) input value
#6L=K0 //(1st point) output value
#8L=K524288 //(2nd point) input value
#10L=K400000 //(2nd point) output value
#12L=K1048576 //(3rd point) input value
#14L=K1000000 //(3rd point) output value
#16L=K2097152 //(4th point) input value
#18L=K300000 //(4th point) output value
#20L=K3145728 //(5th point) input value
#22L=K-1000000 //(5th point) output value
#24L=K4194304 //(6th point) input value
#26L=K-500000 //(6th point) output value
CAMWR K255,K0,K6,#0 //Cam data write
```

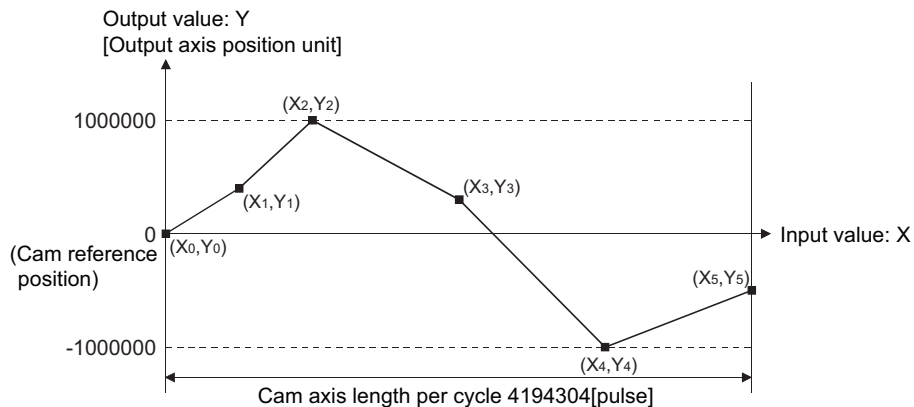

Cam auto-generation: CAMMK

Format	Number of basic steps	Usable steps	
		F/FS	G
CAMMK (S1), (S2), (S3), (D)	13	○	○

Setting data

■ Usable data

○: Usable

Setting data	Usable Data									
	Bit device	Word device			Constant			Calculation expression	Bit conditional expression	Comparison conditional expression
		16-bit integer type	32-bit integer type (L)	64-bit floating point type (F)	16-bit integer type (K/H)	32-bit integer type (K/H, L)	64-bit floating point type (K)			
(S1)	—	○	—	—	○	—	—	—	—	—
(S2)	—	○	—	—	○	—	—	—	—	—
(S3)	—	○	—	—	—	—	—	—	—	—
(D)	—	○	—	—	○	—	—	—	—	—

■ Description, data type of result

Setting data	Description	Data type of result
(S1)	Cam No. (1 to 1024)	—
(S2)	Cam auto-generation type Cam for rotary cutter: 1 Easy stroke ratio cam: 2 Advanced stroke ratio cam: 3	
(S3)	Start device No. which stores the auto-generation data	
(D)	Cam file write destination (0000H to 0401H)	

Processing details

- The auto-generation cam No. data specified with (S1) is created in the cam open area, and the cam file writing destination specified with (D), based on the cam auto-generation type specified with (S2), and the auto-generation data to be stored in the device specified with (S3). By specifying standard ROM to (D), the cam auto-generation will be automatically executed at next power supply ON of the Multiple CPU system.
- Specify the following cam auto-generation type with (S2).

Cam auto-generation type	Setting value
Cam for rotary cutter	1
Easy stroke ratio cam	2
Advanced stroke ratio cam	3

- For (S3), set the auto-generation data for the cam auto-generation type specified with (S2). The specified device No. should be an even number. Assign the auto-generation data to the specified device or later. The device No. storing the end point data must be within the range.
- During the execution of the CAMMK instruction, another CAMWR instruction or CAMMK instruction cannot be processed. During the execution of the CAMMK instruction, the "Cam data operation flag (SM505)" turns on. Therefore, create an interlock. When the CAMWR instruction or CAMMK instruction is executed while the "Cam data operation flag (SM505)" is ON, an error occurs.

- Set the write to cam file, and the cam file write destination to (D). When write to cam file is "0: Do not write", write to cam open area is performed only, and cam data is not written to the cam file.

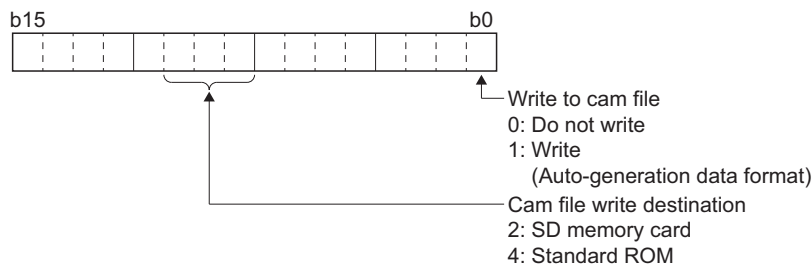

- (D) can be omitted. When (D) is omitted, or is set outside the range, cam data is written to the cam open area only. When performing write to cam file, set (D).

Point

When "1: Write" is set to the write to cam file in (D), write to cam file is performed after completion of write to the cam open area. When an error occurred during cam file operation, the cam data of the cam open area is retained.

Operation error

An operation error will occur, and the cam auto-generation will not be executed if:

- Cam No. specified with (S1) is outside the range of 1 to 1024. (Details code: 1)
- Auto-generation type specified with (S2) is set to a value that does not correspond to an auto-generation type. (Details code: 2)
- The device numbers storing the auto-generation data specified with (S3) are outside the range. (Details code: 5)
- (S3) is not an even-numbered device. (Details code: 6)
- The writable area is insufficient when the cam data is being written. (Details code: 4)
- A value outside the range is set for the auto-generation data. (Details code: 7)
- For the cam for rotary cutter, a value has been set as "sheet synchronization width \geq sheet length" in the auto-generation parameter. (Details code: 8)
- For the cam for rotary cutter, the asynchronous speed will be reduced when the auto-generation data is set as "synchronous axis length (synchronous axis diameter $\times \pi$) $<$ sheet length". (Details code: 9)
- For the cam for rotary cutter, the asynchronous speed is 655.35 times of larger than synchronous speed by auto-generation data. (Details code: 10)
- The CAMMK instruction is executed while the "Cam data operation flag (SM505)" is ON. (Details code: 12)
- For the easy stroke ratio cam or advanced stroke ratio cam, the end point set for each section are not in ascending order. (Details code: 20)
- For the easy stroke ratio cam or advanced stroke ratio cam, the end point of the final section is less than the cam axis length per cycle. (Details code: 21)
- The curve applicable range (P1, P2) or acceleration/deceleration range compensation (L1, L2) in advanced stroke ratio cam are wrong. (Details code: 23)
- The stroke and stroke amount for each section in advanced stroke ratio cam are wrong. (Details code: 7)

In the following cases an operation error occurs, and the write to cam file is not performed. (Write to the cam open area is performed)

- The CAMMK instruction was executed for a cam change data cam file. (Details code: 18)
- An error occurred during cam file access. (Details code: 19)

Cam for rotary cutter

Set the auto-generation data of the rotary cam cutter. (sheet length, synchronization width, etc.)

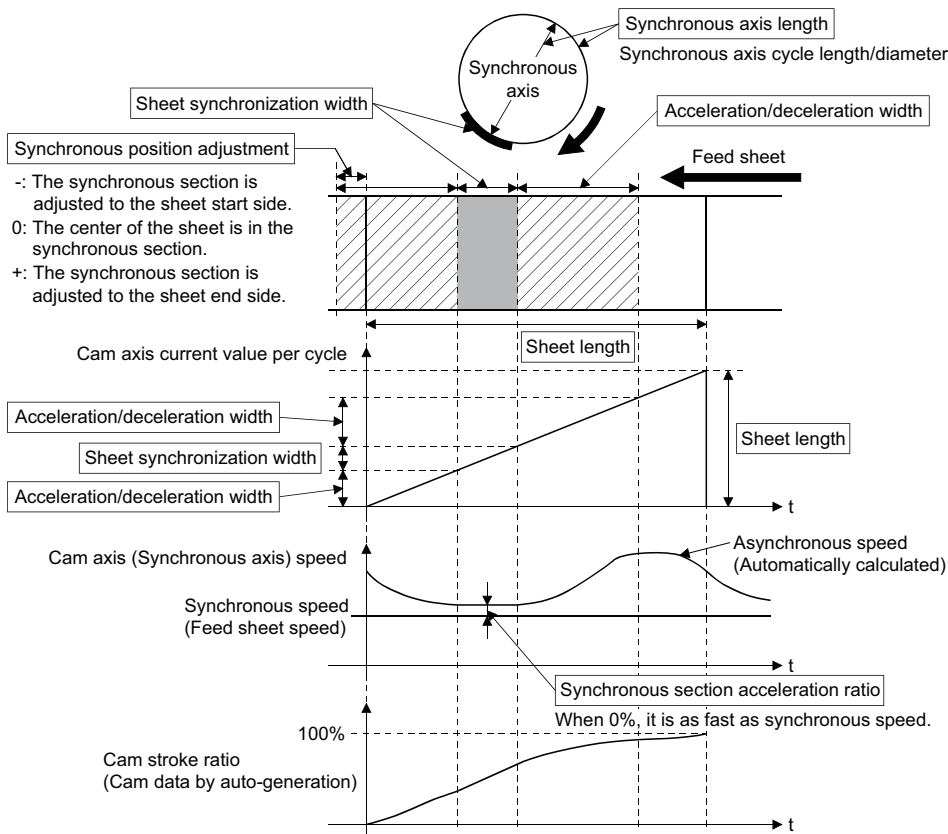

■Device assignment of the cam auto-generation data for the rotary cutter cam

When the synchronous position adjustment is set to 0, the cam pattern of which the sheet center is in the synchronous section is created.

Offset	Name	Description	Range
+0	Resolution	Set the cam resolution for generating the cam.	256/512/1024/2048/4096/8192/ 16384/32768
+1			
+2	Auto-generation option	<ul style="list-style-type: none"> • Select the trapezoidal acceleration/deceleration system or the S-curve acceleration/deceleration system with bit 0. • Select the diameter or the cycle length for the synchronous axis length with bit 1. • Set 0 for bits 2 to 15. 	<ul style="list-style-type: none"> • Bit 0: Acceleration/ deceleration system 0: Trapezoidal acceleration/ deceleration 1: S-curve acceleration/ deceleration • Bit 1: Synchronous axis length setting 0: Diameter 1: Cycle length
+3	Synchronous section acceleration ratio	Set when the synchronous speed in the synchronous section needs to be adjusted. The speed is "Synchronous speed × (100% + Acceleration ratio)" in the synchronous section.	-5000 to 5000[0.01%]
+4	Sheet length	Set the sheet length.	1 to 2147483647 [(Optional) Same units]
+5			
+6	Sheet synchronization width	<ul style="list-style-type: none"> • Set the sheet synchronization width (seal width). • When the synchronous speed section for retracting is required in front of and behind the sheet synchronization width, add the retracting width. 	1 to 2147483647 [(Optional) Same units]
+7			
+8	Synchronous axis length	<ul style="list-style-type: none"> • Set the rotary cutter axis length. • When the synchronous axis length of the auto-generation option is set to the diameter, "Cycle length = setting value × π. • When the synchronous axis length of the auto-generation option is set to the cycle length, "Cycle length = setting value". 	<ul style="list-style-type: none"> • For diameter setting 1 to 680000000 • For cycle length setting 1 to 2147483647 [(Optional) Same units]
+9			
+10	Synchronous position adjustment	<ul style="list-style-type: none"> • Set the position adjustment of the synchronous section. -: The synchronous section is adjusted to the sheet start side. 0: The center of the sheet is in the synchronous section. +: The synchronous section is adjusted to the sheet end side. • Set the value within one-half of the sheet length. 	-1073741823 to 1073741823 [(Optional) Same units]
+11			
+12	Acceleration/ deceleration width	<ul style="list-style-type: none"> • Set the sheet width (one side) of the acceleration/deceleration area. • When a negative value is set, the acceleration/deceleration width is determined to be the maximum. 	0 to 2147483647 [(Optional) Same units] <ul style="list-style-type: none"> • For a value other than the above, the acceleration/ deceleration width is determined to be the maximum.
+13			
+14	Number of cutter	Set the number of cutter.	1 to 256
+15	Asynchronous speed result	When the cam auto-generation is successfully performed, the asynchronous speed is stored as the ratio to the synchronous speed.	0 to 65535 [0.01 times]

Program examples

Program which creates cam data (resolution: 512) for the rotary cutter operation pattern in Cam No.5.

```

D5000L=K512 // Resolution = 512
D5002=K0 // Acceleration/deceleration system = Trapezoidal,
Synchronous axis length setting = Diameter
D5003=K300 // Synchronous section acceleration ratio = 3.00%
D5004L=K2000 // Sheet length = 200.0 mm
D5006L=K500 // Sheet synchronization width = 30.0 mm (Seal section) +
20.0 mm (Retracting operation)
D5008L=K1000 // Synchronous axis length = 100.0 mm(Diameter)
D5010L=K200 // Synchronous position adjustment = 20.0 mm
D5012L=K550 // Acceleration/deceleration width = 55.0 mm
D5014=K1 // Number of cutter = 1
CAMMK K5,K1,D5000 // Cam auto-generation (Asynchronous speed result is stored
in D5015.)
    
```

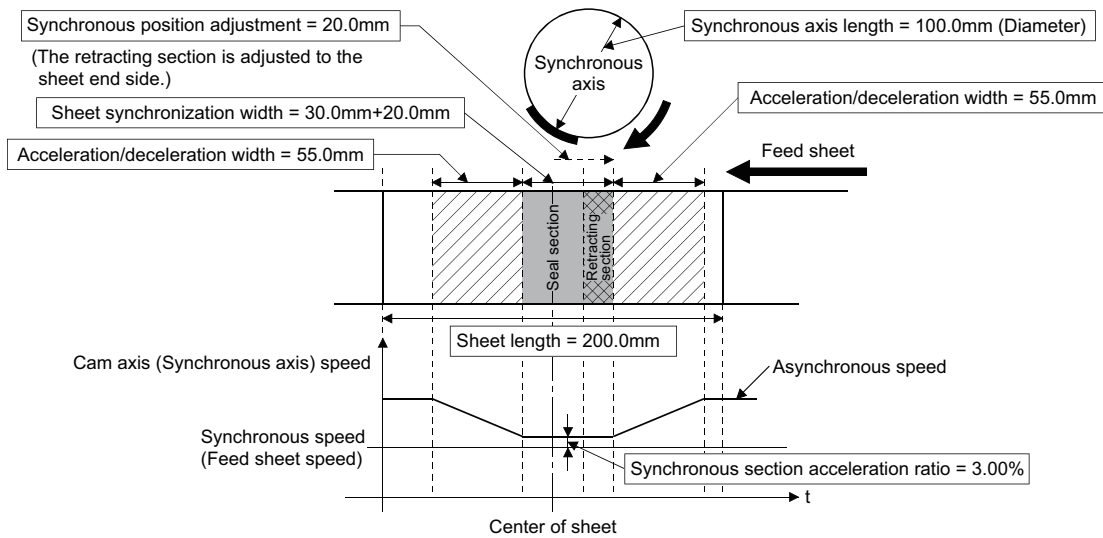

Easy stroke ratio cam/Advanced stroke ratio cam

Cam data can be automatically generated without using the cam data setting of MT Developer2 by setting the stroke amount and sections. In easy stroke ratio cam, detailed coefficients of the cam curve are omitted and the curves and number of sections that can be used are limited. With the current value per cycle "0" as starting point, automatically generates cam data from the stroke and cam curve type of each section until the specified end point (cam axis current value per cycle).

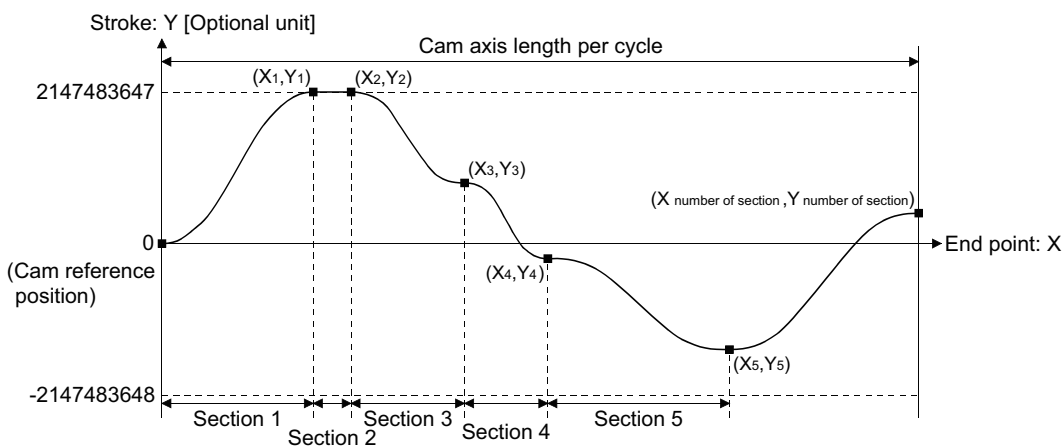

■ Device assignment of the cam auto-generation data

- Easy stroke ratio cam data for auto-generation

Offset	Name	Description	Range	
+0	Resolution	Set the cam resolution for generating the cam.	256/512/1024/2048/4096/ 8192/ 16384/32768	
+1				
+2	Cam axis length per cycle*1	Set the cycle length of one cam operation cycle.	1 to 2147483647 [Cam axis length per cycle units]	
+3				
+4	Cam data starting point	Set the starting point as the point corresponding to "cycle length=0" of cam data.	0 to (Resolution - 1)	
+5				
+6	Number of sections	Set the number of sections of cam data. Set data for the number of sections specified.	1 to 32	
+7	Unusable	Set 0.	0	
+8	Section 1	Cam curve type*2	Set the cam curve. 0: Constant speed 1: Constant acceleration 2: Distorted trapezoid 3: Distorted sine 4: Distorted constant speed 5: Cycloid 6: 5th curve	
+9		Unusable	Set 0. 0	
+10		End point (X ₁)	Set the point for cam axis length per cycle (cam axis current value per cycle). It is necessary to set a value larger than the end point immediately before (X _n <X _{n+1}). Also, for the final end point, set as the cam axis length per cycle.	1 to Cam axis length per cycle [Cam axis length per cycle units]*3
+11				
+12		Stroke (Y ₁)	Set the stroke position from the cam reference position of when at the end point specified by cam axis current value per cycle. When set at 1000000000, it becomes the position set in "[Pr.441] Cam stroke amount (R: D42704+160n, D42705+160n/Q: D15064+150n, D15065+150n)".	-2147483648 to 2147483647 [×0.0000001%]
+13				
+14	Section 2	Cam curve type*2	The data specified by "number of sections" becomes valid. It is not necessary to set the data after the specified number of sections. 0: Constant speed 1: Constant acceleration 2: Distorted trapezoid 3: Distorted sine 4: Distorted constant speed 5: Cycloid 6: 5th curve	
+15		Unusable	0	
+16		End point(X ₂)		1 to Cam axis length per cycle [Cam axis length per cycle units]*3
+17				
+18		Stroke (Y ₂)		-2147483648 to 2147483647 [×0.0000001%]
+19				
⋮	⋮		⋮	
+194	Section 32	Cam curve type*2	0: Constant speed 1: Constant acceleration 2: Distorted trapezoid 3: Distorted sine 4: Distorted constant speed 5: Cycloid 6: 5th curve	
+195		Unusable	0	
+196		End point (X ₃₂)		1 to Cam axis length per cycle [Cam axis length per cycle units]*3
+197				
+198		Stroke (Y ₃₂)		-2147483648 to 2147483647 [×0.0000001%]
+199				

*1 The set value is only used for cam data generation. Control is performed by the output axis parameter "[Pr.439] Cam axis length per cycle (R: D42700+160n, D42701+160n/Q: D15060+150n, D15061+150n)".

*2 Refer to the cam curve list for the shapes of each cam type. (Page 239 Cam curve list) Use P1 = 0, P2 = 1.00, and default values for L1 and L2.

*3 If setting is outside range, the cam axis length per cycle will be set as the final end point of the section settings.

• Advanced stroke ratio cam data for auto-generation

Offset	Name	Description	Range
+0	Resolution	Set the cam resolution for generating the cam.	256/512/1024/2048/4096/ 8192/ 16384/32768
+1			
+2	Cam axis length per cycle* ¹	Set the cycle length of one cam operation cycle.	1 to 2147483647 [Cam axis length per cycle units]
+3			
+4	Cam stroke amount* ¹	Set the reference value for the stroke amount specified by stroke (Yn). When the cam stroke amount units are "%", this is ignored.	1 to 2147483647 [Cam stroke amount units]
+5			
+6	Unit setting	Set the display unit of the cam axis length per cycle, and the unit for cam stroke amount in hexadecimal. When a value outside the range is set, cam data is generated from the default value (7952H).	
+7	Unusable	Set 0.	0
+8	Cam data starting point	Set the starting point as the point corresponding to "cycle length=0" of cam data.	0 to (Resolution - 1)
+9			
+10	Number of sections	Set the number of sections of cam data. Set data for the number of sections specified.	1 to 360
+11	Unusable	Set 0.	0
+12	Section 1	Cam curve type* ²	0: Constant speed 1: Constant acceleration 2: Distorted trapezoid 3: Distorted sine 4: Distorted constant speed 5: Cycloid 6: 5th curve 7: Trapezoid 8: Reverse trapezoid 9: Double hypotenuse 10: Reverse double hypotenuse 11: Single hypotenuse
+13		Unusable	Set 0.
+14	End point (X ₁)	Set the point for cam axis length per cycle (cam axis current value per cycle). It is necessary to set a value larger than the end point immediately before (X _n <X _{n+1}). Also, for the final end point, set as the cam axis length per cycle.	1 to Cam axis length per cycle [Cam axis length per cycle units] ³
+15			
+16	Stroke (Y ₁)* ⁴	Set the stroke position from the cam reference position of when at the end point specified by cam axis current value per cycle. When set at 1000000000, it becomes the position set in "[Pr.441] Cam stroke amount (R: D42704+160n, D42705+160n/Q: D15064+150n, D15065+150n)".	-2147483648 to 2147483647 [Cam stroke units]
+17			
+18	Curve applicable range (P1)	Set the curve applicable range (start point: P1, end point: P2) for the cam curve. Set so that "P1<P2". When "P1=P2=0", "P2=0" is applied.	0 to 100 [×0.01]
+19	Curve applicable range (P2)		
+20	Acceleration/ deceleration range compensation (Range L1)* ²	Set the acceleration/deceleration range (L1, L2) for the cam curve. The range that can be set differs depending on the cam curve. When "L1=L2=0", the default value for each curve is applied.	1 to 9999 [×0.0001]
+21	Acceleration/ deceleration range compensation (Range L2)* ²		

Offset	Name	Description	Range
+22	Section 2	Cam curve type* ² The data specified by "number of sections" becomes valid. It is not necessary to set the data after the specified number of sections.	0: Constant speed 1: Constant acceleration 2: Distorted trapezoid 3: Distorted sine 4: Distorted constant speed 5: Cycloid 6: 5th curve 7: Trapecloid 8: Reverse trapezoid 9: Double hypotenuse 10: Reverse double hypotenuse 11: Single hypotenuse
+23	Unusable		0
+24	End point (X ₂)		1 to Cam axis length per cycle [Cam axis length per cycle units] ³
+25			
+26	Stroke (Y ₂)* ⁴		-2147483648 to 2147483647 [Cam stroke units]
+27			
+28	Curve applicable range (P1)		0 to 100 [×0.01]
+29	Curve applicable range (P2)		
+30	Acceleration/ deceleration range compensation (Range L1)* ²		1 to 9999 [×0.0001]
+31	Acceleration/ deceleration range compensation (Range L2)* ²		
⋮	⋮		⋮
+3602	Section 360	Cam curve type* ²	0: Constant speed 1: Constant acceleration 2: Distorted trapezoid 3: Distorted sine 4: Distorted constant speed 5: Cycloid 6: 5th curve 7: Trapecloid 8: Reverse trapezoid 9: Double hypotenuse 10: Reverse double hypotenuse 11: Single hypotenuse
+3603	Unusable		0
+3604	End point (X ₃₂)		1 to Cam axis length per cycle [Cam axis length per cycle units] ³
+3605			
+3606	Stroke (Y ₃₂)* ⁴		-2147483648 to 2147483647 [Cam stroke units]
+3607			
+3608	Curve applicable range (P1)		0 to 100 [×0.01]
+3609	Curve applicable range (P2)		
+3610	Acceleration/ deceleration range compensation (Range L1)* ²		1 to 9999 [×0.0001]
+3611	Acceleration/ deceleration range compensation (Range L2)* ²		

- *1 The set value is only used for cam data generation. Control is performed by the output axis parameter "[Pr.439] Cam axis length per cycle (R: D42700+160n, D42701+160n/Q: D15060+150n, D15061+150n)", and "[Pr.441] Cam stroke amount (R: D42704+160n, D42705+160n/Q: D15064+150n, D15065+150n)".
- *2 Refer to the cam curve list for the shapes of each cam type, ranges for L1 and L2. (☞ Page 239 Cam curve list) Set "0" for the types of cam curves that do not use L1 and L2.
- *3 If setting is outside range, the cam axis length per cycle will be set as the final end point of the section settings.
- *4 When the cam stroke amount units is a unit other than "%", set the stroke amount so that "Stroke (Yn) / cam stroke amount" is inside the range of "-214.7483648 to 214.7483647"

Point

- Set data for the number of sections specified. It is not necessary to set the data after the number of sections specified.
- Set the end point data in ascending order.
- Various cam patterns are created by the setting of the stroke and cam data of each section. If the amount of change in stroke is large, it may cause a servo error in the servo amplifier including overspeed, data error etc. When creating cam, confirm the cam operation in amplifier-less operation.
- Cam data will end at the section where the end point is exceeds the cam axis length per cycle set by the auto-generation data.

Cam curve list

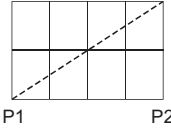
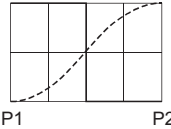
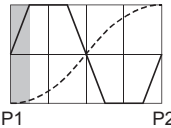
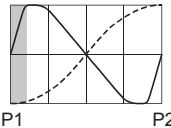
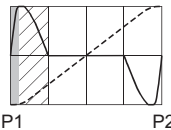
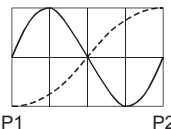
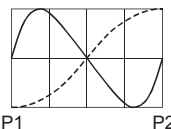
Cam curve type		Acceleration curve shape*1	Curve applicable range (P1 to P2)	Acceleration/deceleration range compensation	
Setting value	Cam curve name			Range L1	Range L2
0	Constant speed Discontinuous		0.00 to 1.00	—	—
1	Constant acceleration		0.00 to 1.00	—	—
2	Distorted trapezoid Two-dwelling symmetrical		0.00 to 1.00	0.0001 to 0.2499 (0.1250)	—
3	Distorted sine		0.00 to 1.00	0.0001 to 0.4999 (0.1250)	—
4	Distorted constant speed		0.00 to 1.00	0.0001 to 0.1249 (0.0625)	0.0001 to 0.4999 (0.2500)
5	Cycloid		0.00 to 1.00	—	—
6	5th curve		0.00 to 1.00	—	—

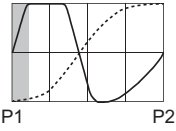
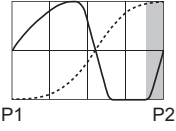
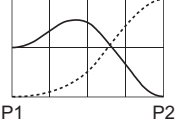
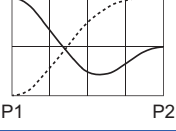
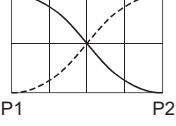
Cam curve type			Acceleration curve shape*1	Curve applicable range (P1 to P2)	Acceleration/deceleration range compensation	
Setting value	Cam curve name				Range L1	Range L2
7	Trapezoid	Two-dwelling asymmetrical		0.00 to 1.00	0.0001 to 0.2499 (0.1250)	—
8	Reverse trapezoid			0.00 to 1.00	0.0001 to 0.2499 (0.1250)	—
9	Double hypotenuse	One-dwelling		0.00 to 1.00	—	—
10	Reverse double hypotenuse			0.00 to 1.00	—	—
11	Single hypotenuse	Non-dwelling curve		0.00 to 1.00	—	—

*1: Stroke ratio —: Acceleration ■: Range L1 ▨: Range L2

■ Program that creates easy stroke ratio cam data

- Program which creates cam data (resolution: 512) in cam No. 5

```

D5000L=K512           //Resolution=512
D5002L=K36000000      //Cam axis length per cycle=360.0[degree]
D5004L=K0             //Cam data starting point=0th point
D5006=K7             //Number of sections=7 sections
D5007=K0             //Unusable
D5008=K0             //(Section 1) Cam curve type=Constant speed
D5009=K0             //Unusable
D5010L=K9000000      //(Section 1) End point (X1)=90.0[degree]
D5012L=K100000000    //(Section 1) Stroke (Y1)=100.0[%]
D5014=K0             //(Section 2) Cam curve type=Constant speed
D5015=K0             //Unusable
D5016L=K12000000     //(Section 2) End point (X2)=120.0[degree]
D5018L=K100000000    //(Section 2) Stroke (Y2)=100.0[%]
D5020=K0             //(Section 3) Cam curve type=Constant speed
D5021=K0             //Unusable
D5022L=K15000000     //(Section 3) End point (X3)=150.0[degree]
D5024L=K700000000    //(Section 3) Stroke (Y3)=70.0[%]
D5026=K0             //(Section 4) Cam curve type=Constant speed
D5027=K0             //Unusable
D5028L=K21000000     //(Section 4) End point (X4)=210.0[degree]
D5030L=K700000000    //(Section 4) Stroke (Y4)=70.0[%]
D5032=K0             //(Section 5) Cam curve type=Constant speed
D5033=K0             //Unusable
D5034L=K24000000     //(Section 5) End point (X5)=240.0[degree]
D5036L=K100000000    //(Section 5) Stroke (Y5)=100.0[%]
D5038=K0             //(Section 6) Cam curve type=Constant speed
D5039=K0             //Unusable
D5040L=K27000000     //(Section 6) End point (X6)=270.0[degree]
D5042L=K100000000    //(Section 6) Stroke (Y6)=100.0[%]
D5044=K0             //(Section 7) Cam curve type=Constant speed
D5045=K0             //Unusable
D5046L=K36000000     //(Section 7) End point (X7)=360.0[degree]
D5048L=K0            //(Section 7) Stroke (Y7)=0[%]
CAMMK K5,K2,D5000    //Cam auto-generation

```

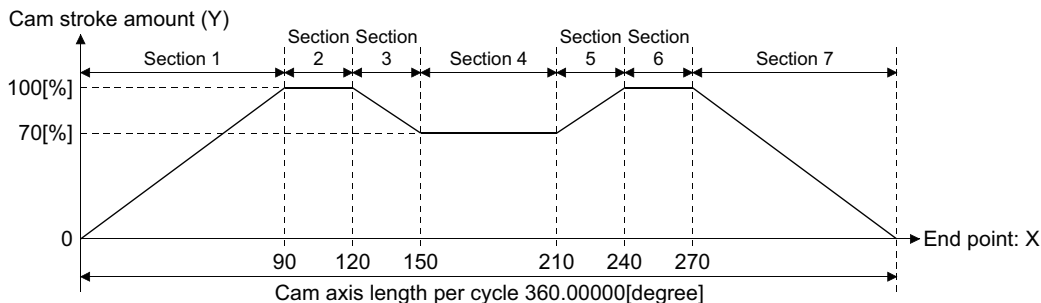

- Program which creates cam data (resolution: 512) in cam No. 6

```

D6000L=K512 //Resolution=512
D6002L=K36000000 //Cam axis length per cycle=360.0[degree]
D6004L=K0 // Cam data starting point=0th point
D6006=K5 //Number of sections=5 sections
D6007=K0 //Unusable
D6008=K0 //(Section 1) Cam curve type=Constant speed
D6009=K0 //Unusable
D6010L=K9000000 //(Section 1) End point (X1)=90.0[degree]
D6012L=K0 //(Section 1) Stroke (Y1)=0[%]
D6014=K0 //(Section 2) Cam curve type=Constant speed
D6015=K0 //Unusable
D6016L=K17000000 //(Section 2) End point (X2)=170.0[degree]
D6018L=K800000000 //(Section 2) Stroke (Y2)=80[%]
D6020=K0 //(Section 3) Cam curve type=Constant speed
D6021=K0 //Unusable
D6022L=K19000000 //(Section 3) End point (X3)=190.0[degree]
D6024L=K800000000 //(Section 3) Stroke (Y3)=80[%]
D6026=K0 //(Section 4) Cam curve type=Constant speed
D6027=K0 //Unusable
D6028L=K27000000 //(Section 4) End point (X4)=270.0[degree]
D6030L=K0 //(Section 4) Stroke (Y4)=0[%]
D6032=K0 //(Section 5) Cam curve type=Constant speed
D6033=K0 //Unusable
D6034L=K36000000 //(Section 5) End point (X5)=360.0[degree]
D6036L=K0 //(Section 5) Stroke (Y5)=0[%]
CAMMK K6,K2,D6000 //Cam auto-generation

```

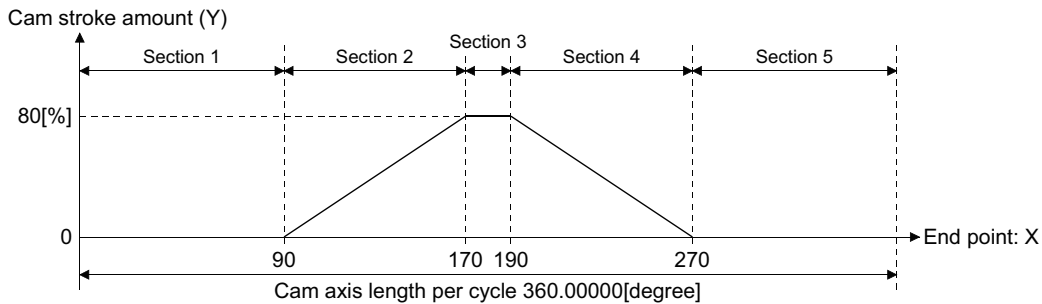

Cam position calculation: CAMPSCL

Format	Number of basic steps	Usable steps	
		F/FS	G
CAMPSCL (S1), (S2), (D)	12	○	○

Setting data

■ Usable data

○: Usable

Setting data	Usable Data								Calculation expression	Bit conditional expression	Comparison conditional expression
	Bit device	Word device			Constant						
		16-bit integer type	32-bit integer type (L)	64-bit floating point type (F)	16-bit integer type (K/H)	32-bit integer type (K/H, L)	64-bit floating point type (K)				
(S1)	—	○	—	—	○	—	—	—	—	—	
(S2)	—	○	—	—	—	—	—	—	—	—	
(D)	—	—	○	—	—	—	—	—	—	—	

■ Description, data type of result

Setting data	Description	Data type of result
(S1)	Cam position calculation: Cam No. (0 to 1024)	—
(S2)	Start device No. which stores the cam position calculation control data	
(D)	Device No. which stores the cam position calculation result	

Processing details

- For the cam No. data specified with (S1), the cam axis current feed value or the cam axis current value per cycle is calculated from the cam position calculation control data specified with (S2), and the value is output to the device specified with (D).
- Specify the cam No. to perform the cam position calculation with (S1). When cam No. 0 is specified, the cam position is calculated as the linear cam. For cam No.1 to 1024, the cam position is calculated with the cam data on the cam open area.
- The device No. specified with (S2) should be an even number. Set the cam position calculation control data in the specified device as follows.

■ Device assignment of the cam position calculation control data

Offset	Name	Description	Range
+0	Cam position calculation type	Specify the cam axis current feed value calculation/cam axis current value per cycle calculation	0: Cam axis current feed value calculation 1: Cam axis current value per cycle calculation
+1	Unusable	Set 0.	0
+2	Cam stroke amount	Set the cam stroke amount for the cam position calculation.	-2147483648 to 2147483647 [Output axis position units]
+3			
+4	Cam axis length per cycle	Set the cam axis length per cycle for the cam position calculation.	1 to 2147483647 [Cam axis cycle unit]
+5			
+6	Cam reference position	Set the cam reference position for the cam position calculation.	-2147483648 to 2147483647 [Output axis position units]
+7			
+8	Cam axis current value per cycle	<ul style="list-style-type: none"> Set the cam axis current value per cycle for the cam position calculation when calculating the cam axis current feed value. Set the cam axis current value per cycle as the starting point to search when calculating the cam axis current value per cycle and the cam position. 	0 to (Cam axis length per cycle) [Cam axis cycle unit]
+9			
+10	Cam axis current feed value	Set the cam axis current feed value for the cam position calculation when calculating the cam axis current value per cycle. (This is not used when the cam position calculation type is set to the cam axis current feed value calculation.)	-2147483648 to 2147483647 [Output axis position units]
+11			

- Specify the device No. with (D) to an even number. The specified device stores the cam position calculation result as shown below when the calculation is completed.

Cam position calculation	Description
Cam axis current feed value calculation	The cam axis current feed value that is calculated within the following range is stored. -2147483648 to 2147483647 [Output axis position units]
Cam axis current value per cycle calculation	The cam axis current value per cycle that is calculated within the following range is stored. 0 to (Cam axis length per cycle-1) [Cam axis cycle unit]

- The cam position calculation does not update the cam reference position automatically.

Operation error

An operation error will occur, and the cam position calculation will not be executed if:

- Cam No. specified with (S1) is outside the range of 0 to 1024. (Details code: 1)
- The cam No. data specified with (S1) does not exist in the cam open area. (Details code: 2)
- The device numbers storing the cam position calculation control data specified with (S2) are outside the range. (Details code: 3)
- (S2) is not an even-numbered device. (Details code: 4)
- Cam position calculation type specified with cam position calculation control data is set to other than 0 or 1. (Details code: 5)
- Cam axis length per cycle is outside the range of 1 to 2147483647. (Details code: 6)
- Cam axis current value per cycle is outside the range of 0 to (cam axis length per cycle). (Details code: 7)
- The device numbers storing the cam position calculation result specified with (D) are outside the range. (Details code: 8)
- (D) is not an even-numbered device. (Details code: 9)
- The cam axis current value per cycle cannot be calculated by the cam axis current value per cycle calculation. (Details code: 10)

Program example

■Program which calculates the cam axis current feed value in the linear cam pattern (cam No. 0)

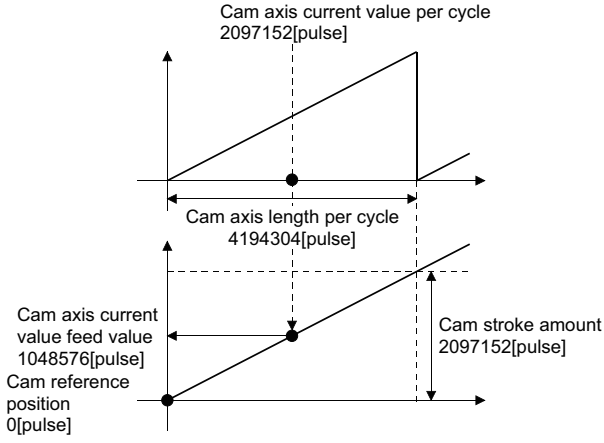
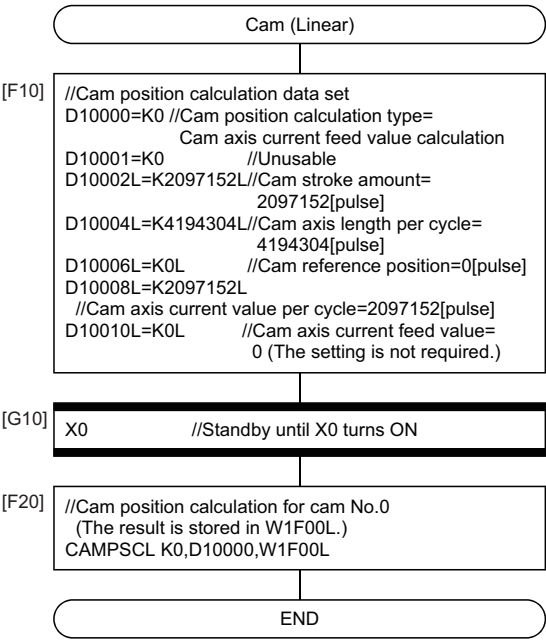

Program which calculates the cam axis current feed value in the two-way cam pattern operation

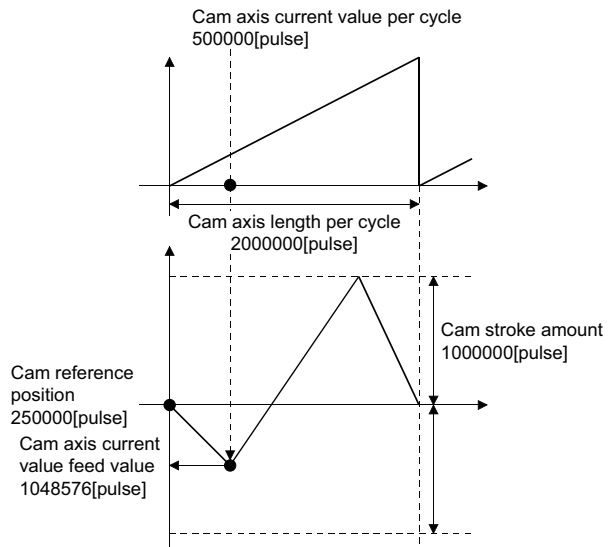
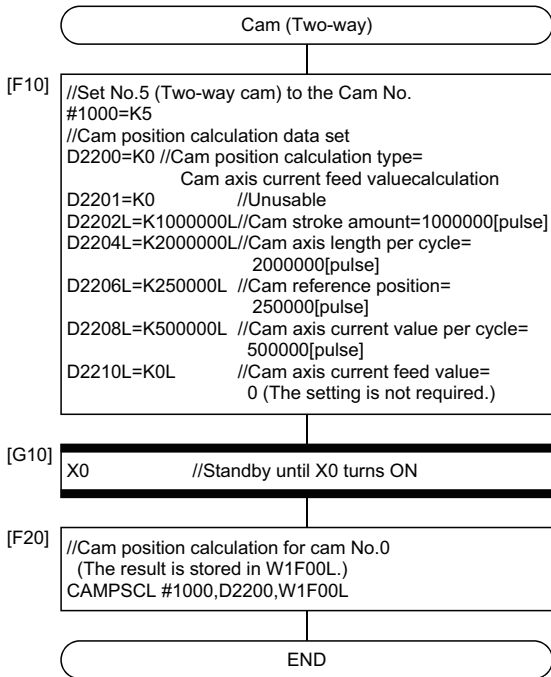

Program which calculates the cam axis current value per cycle in the feed operation cam pattern

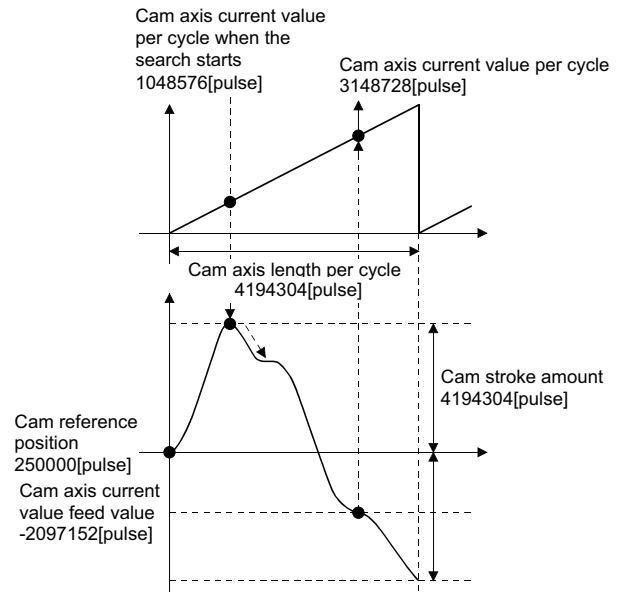
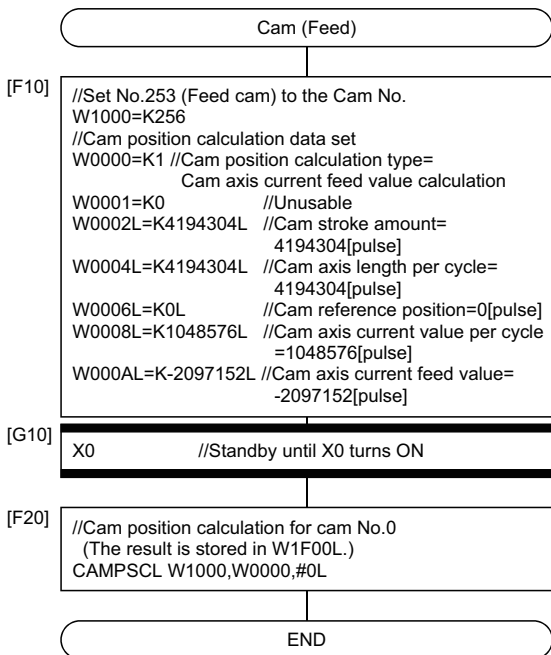

4.17 Vision System Dedicated Function

Open line: MVOOPEN

Format	Number of basic steps	Usable steps	
		F/FS	G
MVOOPEN(S1), (S2)	8	○	○

Setting data

■ Usable data

○: Usable

Setting data	Usable Data									
	Bit device	Word device			Constant			Calculation expression	Bit conditional expression	Comparison conditional expression
		16-bit integer type	32-bit integer type (L)	64-bit floating point type (F)	16-bit integer type (K/H)	32-bit integer type (K/H, L)	64-bit floating point type (K)			
(S1)	—	○	—	—	○	—	—	—	—	—
(S2)	—	○	—	—	○	—	—	—	—	—

■ Description, data type of result

Setting data	Description	Data type of result
(S1)	Vision system (camera) No. to log on (1 to 32)	—
(S2)	Timeout until vision system logon is completed (1 to 32767) [×10ms]	—

Processing details

- The vision system specified with (S1) is logged on.
- The Motion SFC program execution transits to the next block without waiting for the completion on the vision system logon. After process completion, the status storage device value set in the Ethernet communication line setting parameter is 20 (reception enable).
- (S2) is set in increments of 10ms. When the setting is omitted, the timeout time is 10 seconds (same as setting 1000).

Operation error

An operation error will occur if:

- The (S1) data is outside the range of 1 to 32.
- The (S2) data is outside the range of 1 to 32767.
- MVOOPEN is executed again for the vision system that has been logged on.
- The vision system parameter setting is different from the setting on the vision system.
- The logon is not completed when the specified timeout time has elapsed.

Program example

■ Program which logs on the vision system of the vision system (camera) 3

```
MVOOPEN K3
```

Load a program: MVLOAD

Format	Number of basic steps	Usable steps	
		F/FS	G
MVLOAD(S1), (S2)	8	○	○

Setting data

■ Usable data

○: Usable

Setting data	Usable Data									
	Bit device	Word device			Constant			Calculation expression	Bit conditional expression	Comparison conditional expression
		16-bit integer type	32-bit integer type (L)	64-bit floating point type (F)	16-bit integer type (K/H)	32-bit integer type (K/H, L)	64-bit floating point type (K)			
(S1)	—	○	—	—	○	—	—	—	—	—
(S2)	—	○	—	—	○	—	—	—	—	—

■ Description, data type of result

Setting data	Description	Data type of result
(S1)	Vision program No. to load (1 to 128)	—
(S2)	Timeout time until the job loading completed (1 to 32767) [×10ms]	—

Processing details

- The job of the vision program No. specified with (S1) is loaded to the vision system (The process of developing a job file stored in the vision system into the memory in the vision system, and making it an active job). And the status is changed to on-line.
- The Motion SFC program execution transits to the next block without waiting for the process completion. After process completion, the status storage device value set in the Ethernet communication line setting parameter is 20 (reception enabled). When the job loading is executed successfully and the vision system becomes online, the status storage device value set in the vision program operation setting parameter specified with (S1) is 1 (Online after the job loading completed).
- When the job of the vision program No. specified with (S1) has been loaded to the vision system, the job is forced to reload. When job contents have been changed by In-Sight® Explorer, etc., save the job in advance to prevent from losing.
- (S2) is set in increments of 10ms. When the setting is omitted, the timeout time is 10 seconds (same as setting 1000). The process time is changed according to job contents in the vision system. Set the timeout time according to the vision system and the job contents.

Operation error

An operation error will occur if:

- The (S1) data is outside the range of 1 to 128.
- The (S2) data is outside the range of 1 to 32767.
- The vision system which is used in the vision program specified with (S1) has not been logged on.
- The vision system parameter setting is different from the setting on the vision system and the job.
- The job loading is not completed when the specified timeout time has elapsed.

Program example

■ Program which loads the job of the vision program No.2

```
MVLOAD K2
```

Send an image acquisition trigger: MVTRG

Format	Number of basic steps	Usable steps	
		F/FS	G
MVTRG(S1), (S2)	8	○	○

Setting data

■ Usable data

○: Usable

Setting data	Usable Data									
	Bit device	Word device			Constant			Calculation expression	Bit conditional expression	Comparison conditional expression
		16-bit integer type	32-bit integer type (L)	64-bit floating point type (F)	16-bit integer type (K/H)	32-bit integer type (K/H, L)	64-bit floating point type (K)			
(S1)	—	○	—	—	○	—	—	—	—	—
(S2)	—	○	—	—	○	—	—	—	—	—

■ Description, data type of result

Setting data	Description	Data type of result
(S1)	Vision system (camera) No. issues a trigger (1 to 32)	—
(S2)	Timeout time until execution result is received from vision system (1 to 32767) [$\times 10\text{ms}$]	

Processing details

- The job is executed if a trigger is issued to the vision system specified with (S1) and the result is stored in the image data storage device set in the vision program operation setting parameter.
- The Motion SFC program execution transits to the next block without waiting for the process completion. After the job is ended in the vision system and the sending of image data (created by vision processing) by TCP/IP protocol is completed, the status storage device value set in the Ethernet communication line setting parameter is 40 (Image data reception completed). When the read value is set in the vision system parameters, the data is stored in the read value storage device, and the status storage device value set in the Ethernet communication line setting parameter is 50 (value cell reception completed).
- (S2) is set in increments of 10ms. When the setting is omitted, the timeout time is 10 seconds (same as setting 1000).

Operation error

An operation error will occur if:

- The (S1) data is outside the range of 1 to 32.
- The (S2) data is outside the range of 1 to 32767.
- The vision system specified with (S1) has not been logged on.
- The vision system parameter setting is different from the setting on the vision system.
- The tag specified with reading value cell or the spreadsheet data is not an integer value.
- The current process is not completed when the specified timeout time has elapsed.

Program example

■ Program which issues a trigger to the vision system (camera) 1

MVTRG K1

Start a program: MVPST

Format	Number of basic steps	Usable steps	
		F/FS	G
MVPST(S1), (S2)	8	○	○

Setting data

■ Usable data

○: Usable

Setting data	Usable Data									
	Bit device	Word device			Constant			Calculation expression	Bit conditional expression	Comparison conditional expression
		16-bit integer type	32-bit integer type (L)	64-bit floating point type (F)	16-bit integer type (K/H)	32-bit integer type (K/H, L)	64-bit floating point type (K)			
(S1)	—	○	—	—	○	—	—	—	—	—
(S2)	—	○	—	—	○	—	—	—	—	—

■ Description, data type of result

Setting data	Description	Data type of result
(S1)	Vision program No. to start (1 to 128)	—
(S2)	Timeout time until execution result is received from vision system (1 to 32767) [$\times 10\text{ms}$]	

Processing details

- The job of the vision program No. specified with (S1) is loaded to the vision system (The process of developing a job file stored in the vision system into the memory in the image system, and making it an active job). And the status is changed to on-line. Then, the job is executed if a trigger is issued, and the result is stored in the image data storage device set in the vision program operation setting parameter.
- The Motion SFC program execution transits to the next block without waiting for the process completion. After the job is ended in the vision system and the sending of vision data (created by vision processing) by TCP/IP protocol is completed, the status storage device value set in the Ethernet communication line setting parameter is 40 (Image data reception completed). When the read value is set in the vision system parameters, the data is stored in the read value storage device, and the status storage device value set in the Ethernet communication line setting parameter is 50 (value cell reception completed).
- When the job of the vision program No. specified with (S1) has been loaded to the vision system, the following process is executed without reloading. The job is executed if a trigger is issued to the vision system, and the result is stored in the image data storage device set in the vision program operation setting parameter.
- (S2) is set in increments of 10ms. When the setting is omitted, the timeout time is 10 seconds (same as setting 1000). The process time is changed according to job contents in the vision system. Set the timeout time according to the vision system and the job contents.

Operation error

An operation error will occur if:

- The (S1) data is outside the range of 1 to 128.
- The (S2) data is outside the range of 1 to 32767.
- The vision system which is used in the vision program specified with (S1) has not been logged on.
- The vision system parameter setting is different from the setting on the vision system and the job.
- The tag specified with reading value cell or the spreadsheet data is not an integer value.
- The current process is not completed when the specified timeout time has elapsed.

Program example

■Program which executes the job of the vision program No.20

MVPST K20

Input data: MVIN

Format	Number of basic steps	Usable steps	
		F/FS	G
MVIN(S1), (S2), (D), (S3)	15 or more	○	○

Setting data

Usable data

○: Usable

Setting data	Usable Data								Calculation expression	Bit conditional expression	Comparison conditional expression
	Bit device	Word device			Constant						
		16-bit integer type	32-bit integer type (L)	64-bit floating point type (F)	16-bit integer type (K/H)	32-bit integer type (K/H, L)	64-bit floating point type (K)				
(S1)	—	○	—	—	○	—	—	—	—	—	
(S2)	—	○*1	—	—	—	—	—	—	—	—	
(D)	—	—	○*2	○*2	—	—	—	—	—	—	
(S3)	—	○	—	—	○	—	—	—	—	—	

*1 Specify the start device which stores the character string data. The character string can be specified directly.

*2 Data is the same format as the job set in the vision system. (If the format is different, the data is converted to the type specified with (D).)

Description, data type of result

Setting data	Description	Data type of result
(S1)	Vision system (camera) No. to which data will be read (1 to 32)	—
(S2)	Spreadsheet cell or tag to which data will be read	
(D)	Device which will store the reading data	
(S3)	Timeout time until data is read from vision system (1 to 32767) [×10ms]	

Processing details

- The numerical value of spreadsheet cell or tag specified with (S2) is stored in the device specified with (D) from the vision system specified with (S1).

Point

The minor error (SFC) (error code: 38F2H) will occur if data of spreadsheet cell or tag specified with (S2) is not a numerical value (character string, etc.). Use MVCOM instruction (Refer to  Page 257 Send a command for native mode: MVCOM).

- The Motion SFC program execution transits to the next block without waiting for the process completion. After process completion, the status storage device value set in the Ethernet communication line setting parameter is 20 (reception enabled).
- In (S2), write directly the spreadsheet cell or tag as a 32 one-byte character or less character string enclosed with double quotation, or set the head of a device in which a 32 one-byte character or less character string is stored. Designation methods of the character string are shown below.

Designation methods	Description
Setting with cell	The spreadsheet row (A to Z) and line (0 to 399) are arranged and written. (Example) When cell is A5, "A5" is set.
Setting with tag	The Symbolic tag name is written in the original state. (Example) When tag is Job.Pass_count, "Job.Pass_count" is set.

- The numerical value read from the vision system is stored with the following format.

Numerical data format of spreadsheet cell or tag	Data format stored in (D)	Number of points
Integer value	32-bit integer value type	Consecutive 2 points
Floating-point value	64-bit floating-point type	Consecutive 4 points

- (S3) is set in increments of 10ms. When the setting is omitted, the timeout time is 10 seconds (same as setting 1000).

Operation error

An operation error will occur if:

- The (S1) data is outside the range of 1 to 32.
- The number of character string of spreadsheet cell or tag specified with (S2) outside the range of 1 to 32 bytes.
- The spreadsheet cell or tag specified with (S2) does not exist.
- The data of spreadsheet cell or tag specified with (S2) is not a numerical value.
- The (S3) data is outside the range of 1 to 32767.
- The vision system specified with (S1) has not been logged on.
- The vision system parameter setting is different from the setting on the vision system.
- The reading data is not completed when the specified timeout time has elapsed.

Program example

■Program which stores the numerical value stored in the tag "pattern_1.fixture.score" of the vision system (camera) 1 to D3000 or later

```
MVIN K1, "pattern_1.fixture.score", D3000F
```

■Program which stores the numerical value from the tag indicated by a character string stored in D100 or later, to D2000 or later for the vision system (camera) 3

```
MVIN K3, D100, D2000L
```

Output data: MVOU

Format	Number of basic steps	Usable steps	
		F/FS	G
MVOU (S1), (S2), (S3), (S4)	15 or more	○	○

Setting data

Usable data

○: Usable

Setting data	Usable Data								Calculation expression	Bit conditional expression	Comparison conditional expression
	Bit device	Word device			Constant						
		16-bit integer type	32-bit integer type (L)	64-bit floating point type (F)	16-bit integer type (K/H)	32-bit integer type (K/H, L)	64-bit floating point type (K)				
(S1)	—	○	—	—	○	—	—	—	—	—	
(S2)	—	○*1	—	—	—	—	—	—	—	—	
(S3)	—	○*2	○*2	○*2	○*2	○*2	○*2	—	—	—	
(S4)	—	○	—	—	○	—	—	—	—	—	

*1 Specify the start device which stores the character string data. The character string can be specified directly.

*2 Data is the same format as data to be transferred. The character string can be specified directly.

Description, data type of result

Setting data	Description	Data type of result
(S1)	Vision system (camera) No. to transfer data (1 to 32)	—
(S2)	Spreadsheet cell or tag to transfer data	
(S3)	Data to be transferred	
(S4)	Timeout time until data is transferred to vision system (1 to 32767) [×10ms]	

Processing details

- Data specified with (S3) is transferred to spreadsheet cell or tag specified with (S2) of vision system specified with (S1).
- The Motion SFC program execution transits to the next block without waiting for the process completion. After process completion, the status storage device value set in the Ethernet communication line setting parameter is 20 (reception enabled).
- In (S2), write directly the spreadsheet cell or tag as a 32 one-byte character or less character string enclosed with double quotation, or set the head of a device in which a 32 one-byte character or less character string is stored. Designation methods of the character string are shown below.

Designation methods	Description
Setting with cell	The spreadsheet row (A to Z) and line (0 to 399) are arranged and written. (Example) When cell is A5, "A5" is set.
Setting with tag	The Symbolic tag name is written in the original state. (Example) When tag is Job.Pass_count, "Job.Pass_count" is set.

- In (S3), set the head of a device that store data to be transferred to spreadsheet cell or tag. Also, the character string of constants or 99 one-byte character or less character string can be specified directly.

[Indirect specification]

Data type specified with (S3)	Number of points	Setting example
16-bit integer value type	1 point	D1000
32-bit integer value type	Consecutive 2 points	D2000L
64-bit floating-point type	Consecutive 4 points	D3000F

[Direct specification]

Data type specified with (S3)	Setting example
16-bit integer value type	K12345
32-bit integer value type	K12345678L
64-bit floating-point type	K1234.5
Character string	"MITSUBISHI"

Point

If the floating-point data is transferred to the vision system, it is handled as 32-bit floating-point data. The number of effective digits is approx. 7 digits. Data in the seven digits or later may not match the (S3) data.

- (S4) is set in increments of 10ms. When the setting is omitted, the timeout time is 10 seconds (same as setting 1000).

Operation error

An operation error will occur if:

- The (S1) data is outside the range of 1 to 32.
- The number of character string of spreadsheet cell or tag specified with (S2) outside the range of 1 to 32 bytes.
- The spreadsheet cell or tag specified with (S2) does not exist.
- The data type of spreadsheet cell or tag specified with (S2) is different from data format specified with (S3).
- The (S3) data is outside the range.
- The (S4) data is outside the range of 1 to 32767.
- The vision system specified with (S1) has not been logged on.
- The vision system parameter setting is different from the setting on the vision system.
- The reading data is not completed when the specified timeout time has elapsed.

Program example

■ Program which transfers the floating-point value stored in D3000F to the tag "Calib_1.World_Point0.X" of the vision system (camera) 1

```
MVOUT K1, "Calib_1.World_Point0.X", D3000F
```

Reset a status storage device: MVFIN

Format	Number of basic steps	Usable steps	
		F/FS	G
MVFIN(S)	6	○	○

Setting data

Usable data

○: Usable

Setting data	Usable Data									
	Bit device	Word device			Constant			Calculation expression	Bit conditional expression	Comparison conditional expression
		16-bit integer type	32-bit integer type (L)	64-bit floating point type (F)	16-bit integer type (K/H)	32-bit integer type (K/H, L)	64-bit floating point type (K)			
(S)	—	○	—	—	○	—	—	—	—	—

Description, data type of result

Setting data	Description	Data type of result
(S)	Vision system (camera) No. to reset the status storage device (1 to 32)	—

Processing details

- The status storage device value set in the Ethernet communication line setting parameter specified with (S) is 20 (reception enabled).
- When a trigger is issued to the vision system, the status storage device is reset by MVFIN instruction in advance, and the process completion for trigger needs to be detected.

Operation error

An operation error will occur if:

- The (S) data is outside the range of 1 to 32.
- The vision system specified with (S) has not been logged on.
- The vision system parameter setting is different from the setting on the vision system.
- The status storage device value set in the Ethernet communication line setting parameter is not 20 (reception enabled), 40 (Image data reception completed), or 50 (value cell reception completed).

Program example

Program which resets the status storage device for the vision system (camera) 1

```
MVFIN K1
```

Close line: MVCLOSE

Format	Number of basic steps	Usable steps	
		F/FS	G
MVCLOSE(S)	6	○	○

Setting data

■ Usable data

○: Usable

Setting data	Usable Data									
	Bit device	Word device			Constant			Calculation expression	Bit conditional expression	Comparison conditional expression
		16-bit integer type	32-bit integer type (L)	64-bit floating point type (F)	16-bit integer type (K/H)	32-bit integer type (K/H, L)	64-bit floating point type (K)			
(S)	—	○	—	—	○	—	—	—	—	—

■ Description, data type of result

Setting data	Description	Data type of result
(S)	Vision system (camera) No. to log off (1 to 32)	—

Processing details

- The vision system specified with (S) is logged off (disconnected). The status storage device value set in the Ethernet communication line setting parameter is 0 (not connected).
- MVCLOSE instruction is not operated for the vision system which is not logged on (not connected).

Operation error

An operation error will occur if:

- The (S) data is outside the range of 1 to 32.
- The vision system parameter setting is different from the setting on the vision system.

Program example

■ Program which logs off the vision system of the vision system (camera) 1

```
MVCLOSE K1
```

Send a command for native mode: MVCOM

Format	Number of basic steps	Usable steps	
		F/FS	G
MVCOM(S1), (S2), (D), (S3), (S4)	19 or more	○	○

Setting data

■ Usable data

○: Usable

Setting data	Usable Data									
	Bit device	Word device			Constant			Calculation expression	Bit conditional expression	Comparison conditional expression
		16-bit integer type	32-bit integer type (L)	64-bit floating point type (F)	16-bit integer type (K/H)	32-bit integer type (K/H, L)	64-bit floating point type (K)			
(S1)	—	○	—	—	○	—	—	—	—	—
(S2)	—	○*1	—	—	—	—	—	—	—	—
(D)	—	○	—	—	—	—	—	—	—	—
(S3)	—	○	—	—	○	—	—	—	—	—
(S4)	—	○	—	—	○	—	—	—	—	—

*1 Specify the start device which stores the character string data. The character string can be specified directly.

■ Description, data type of result

Setting data	Description	Data type of result
(S1)	Vision system (camera) No. to which Native Mode command will be sent (1 to 32)	—
(S2)	Native Mode command character string	
(D)	Start device which stores return value	
(S3)	Mode setting for return value conversion	
(S4)	Timeout time until data is read from vision system (1 to 32767) [×10ms]	

Processing details

- Native Mode command specified with (S2) is sent to the vision system specified with (S1), and the return value is stored in the device specified with (D) with the format specified with (S3).
- The Motion SFC program execution transits to the next block without waiting for the Native Mode command completion. After process completion, the status storage device value set in the Ethernet communication line setting parameter is 20 (reception enabled).
- Refer to the Cognex Corporation vision system manual and help sections, etc. for details of Native Mode command specified with (S2). In (S2), write directly the Native Mode command as a 99 one-byte character or less character string enclosed with double quotation, or set the head of a device in which a 191 one-byte character or less character string is stored.

- The return value of Native Mode command is stored as below by specifying (S3) in the device specified with (D). When the return value data is the following ([CR] indicates a return code, and [LF] indicates a line feed code.)

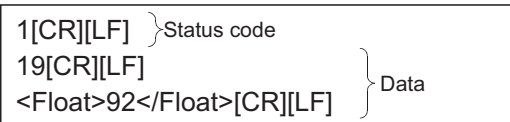

■0(ASCII mode) specification

When 0 (ASCII Mode) is specified with (S3), the data is stored from the device specified with (D) by the following procedure.

1. Status code (16-bit integer format)



2. Number of character string parts of data 3. (16-bit integer format)



3. The character string parts of data (ASCII code)
(The end code [NULL] is stored at the end of data.)

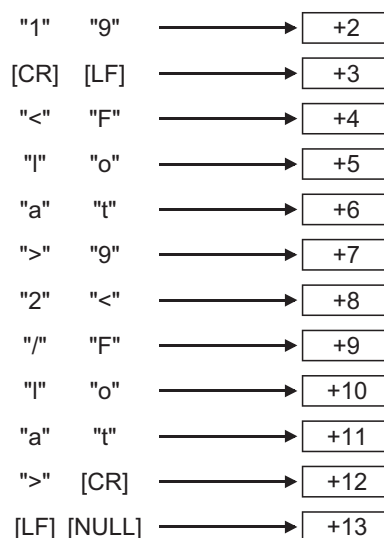

■1(Binary mode) specification

When 1 (Binary Mode) is specified with (S3), the data is stored from the device specified with (D) by the following procedure.

1. Status code (16-bit integer format)



2. Number of character string parts of data 3. (16-bit integer format)



3. Data converted into a 64-bit floating-point type value

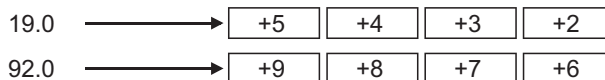

- (S4) is set in increments of 10ms. When the setting is omitted, the timeout time is 10 seconds (same as setting 1000).

Operation error

An operation error will occur if:

- The (S1) data is outside the range of 1 to 32.
- The Native Mode command specified with (S2) is wrong.
- The (S3) data is outside the range of 0 to 1.
- The (S4) data is outside the range of 1 to 32767.
- The vision system specified with (S1) has not been logged on.
- The character string for Native Mode specified with (S2) exceeds the range of the number of characters.
- The return value data is not a numerical value when 1 (Binary Mode) is specified with (S3).
- The vision system parameter setting is different from the setting on the vision system.
- The device storage of the Native Mode command return value is not completed when the specified timeout time has elapsed.
- The return value of Native Mode command exceeds the range of (D) to the end of the device. (An operation error occurs at the storing of data up until the end of the device)

Program example

■ **Program which sends the Native Mode command "EV GetCellValue ("distance_1.max")" to the vision system (camera) 1, and stores the return value in #0 or later in Binary Mode**

```
MVCOM K1,"EV GetCellValue ("distance_1.max")",#0,K1
```

4.18 Add-on Dedicated Function

Call add-on module: MCFUN

Format	Number of basic steps	Usable steps	
		F/FS	G
MCFUN(S1), (S2), (D1), (D2)	11 or more	○	○

Setting data

■ Usable data

○: Usable

Setting data	Usable Data									
	Bit device	Word device			Constant			Calculation expression	Bit conditional expression	Comparison conditional expression
		16-bit integer type	32-bit integer type (L)	64-bit floating point type (F)	16-bit integer type (K/H)	32-bit integer type (K/H, L)	64-bit floating point type (K)			
(S1)	—	○*1	—	—	—	—	—	—	—	—
(S2)	—	○	—	—	—	—	—	—	—	—
(D1)	—	○	—	—	—	—	—	—	—	—
(D2)	○	○	—	—	—	—	—	—	—	—

*1 Specify the start device which stores the character string data. The character string can be specified directly.

■ Description, data type of result

Setting data	Description	Data type of result
(S1)	Add-on module name	—
(S2)	Start device which stores the add-on module input value	
(D1)	Start device which stores the add-on module output value	
(D2)	Add-on module execution complete flag	

Processing details

- Add-on module specified with (S1) is called, the input value is delivered by the device specified with (S2), and the output value is received by the device specified with (D1). When the execution of an add-on module is completed, the execution complete flag specified with (D2) turns ON.
- Reset the execution complete flag with the user program.
- Refer to the instruction manual of the add-on library to be installed for the add-on module name specified with (S1). In (S1), write directly the add-on module name as a 31 one-byte character or less character string enclosed with double quotations, or set the head of a device in which a 31 one-byte character or less character string is stored.
- Specify the device No. with (S2) and (D1) to an even number.
- (S2), (D1), and (D2) can be omitted. Description examples for omitting are given below.

Details	Description example
Not omitting	MCFUN "AddonFunc1",D5000,D5100,M0
Omitting (D2) only	MCFUN "AddonFunc1",D5000,D5100,
Omitting (S2) and (D1)	MCFUN "AddonFunc1",,,M0
Omitting (S2), (D1), and (D2)	MCFUN "AddonFunc1",,,

- The operation for when (S2) and (D1) are omitted differs depending on the add-on module called.
- When (D2) is specified, the Motion SFC program execution transits to the next block without waiting for the add-on module completion. Add-on module processing is executed in the background. One add-on module can be executed in the background. An error occurs when add-on modules are executed in succession in the background without waiting for (D2) to turn ON.
- When (D2) is omitted, the Motion SFC program execution waits for the add-on module completion, and then transits to the next block.

- Refer to the instruction manual of the add-on library to be installed for details of devices specified to (S2), (D1), and (D2).

Operation error

An operation error will occur if:

- The add-on module specified with (S1) is not registered.
- The character string specified with (S1) exceeds 31 characters.
- (S2) and (D1) are not even-numbered devices.
- (S1), (S2), (D1), (D2) are indirectly specified devices, and outside of the device number range.
- Before the execution of an add-on module is completed, another add-on module is executed.

Program example

■ Program which uses the data of D3100 to call the add-on module "AddonFunc1", and stores the result in D3200

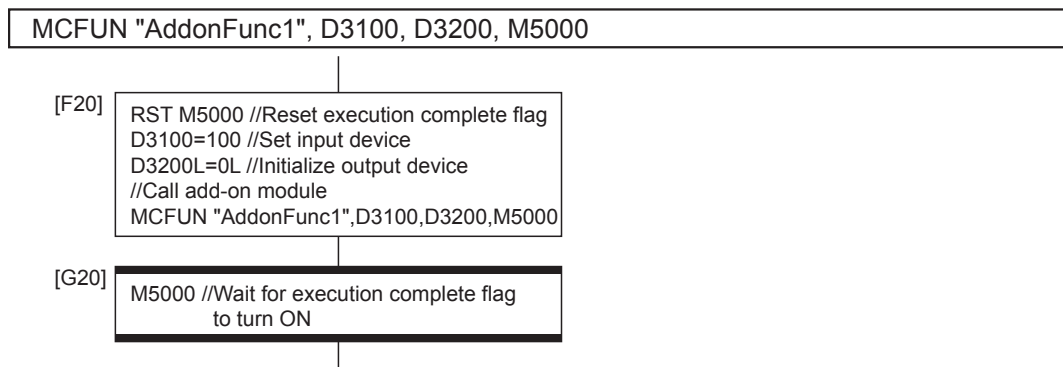

4.19 Other Instructions

Event task enable: EI

Format	Number of basic steps	Usable steps	
		F/FS	G
EI	1	<input type="radio"/>	<input type="radio"/>

Setting data

There are no setting data.

Processing details

- The execution of an event task is enabled.
- This instruction is usable with a normal task only.

Operation error

An operation error will occur if:

- This instruction is used with other than a normal task.

Program example

■ Enables the execution of an event task.

```
EI
```

Event task disable: DI

Format	Number of basic steps	Usable steps	
		F/FS	G
DI	1	○	○

Setting data

There are no setting data.

Processing details

- The execution of an event task is disabled.
- If an external interrupt or PLC interrupt occurs after execution of the DI instruction, the corresponding event task is executed once at the execution of the EI instruction. (If two or more external interrupts or PLC interrupts occur during DI, the corresponding event task is executed only once at the execution of the EI instruction.)
- During DI, a fixed-cycle event task is not executed.
- The execution of an NMI task cannot be disabled.
- The DI status is established at power-on or reset of the Multiple CPU system. EI/DI status does not change by the ON/OFF of "[Rq.1120] PLC ready flag (R: M30000/Q: M2000)".

Operation error

An operation error will occur if:

- This instruction is used with other than a normal task.

Program example

■ Program which disables the execution of an event task.

DI

No operation: NOP

Format	Number of basic steps	Usable steps	
		F/FS	G
NOP	1	○	○

Setting data

There are no setting data.

Processing details

This is a no-operation instruction and does not affect the preceding operations.

Operation error

There are no operation errors.

Block transfer: BMOV

Format	Number of basic steps	Usable steps	
		F/FS	G
BMOV(D), (S), (n)	12	○	○

Setting data

■ Usable data

○: Usable

Setting data	Usable Data									
	Bit device	Word device			Constant			Calculation expression	Bit conditional expression	Comparison conditional expression
		16-bit integer type	32-bit integer type (L)	64-bit floating point type (F)	16-bit integer type (K/H)	32-bit integer type (K/H, L)	64-bit floating point type (K)			
(D)	○	○	—	—	—	○	—	—	—	—
(S)	○	○	—	—	—	○	—	—	—	—
(n)	—	○	○	—	○	○	—	—	—	—

■ Description, data type of result

Setting data	Description	Data type of result
(D)	Transfer destination device starting No.	—
(S)	Transfer source device starting No.	
(n)	Number of words to be transferred (1 to 100000000)	

Processing details

- The contents for n words from device specified with (S) are batch-transferred to the n words from device specified with (D).
- Data can be transferred if the devices of the transfer source and destination overlap. Data are transferred from devices, starting with the one at (S), for transfer of data from devices of larger numbers to those of smaller numbers, or starting with the one at (S)+(n-1) for transfer of data from devices of smaller numbers to those of larger numbers.
- Adjust an executive task, the number of transfer word referring to the operation processing time so that this instruction may not obstruct the execution of the Motion operation because processing time becomes long in argument to the number of words (n) to be written.
- The combinations for transfer destination device and transfer source device that are set to (D) and (S) are shown below.

○: Combination possible, ×: Combination not possible

Transfer source device(S)	Transfer destination device(D)							
	User device/ System device	CPU buffer memory access device		CPU buffer memory access device (fixed scan communication area)		Module access device		
		Self CPU	Other CPU	Self CPU	Other CPU	Self CPU controlled	Other CPU controlled	
User device/System device	○	○	×	○	×	○	×	
CPU buffer memory access device	Self CPU	○	○	×	○	×	○	×
	Other CPU	○	○	×	○	×	×	×
CPU buffer memory access device (fixed scan communication area)	Self CPU	○	○	×	○	×	○	×
	Other CPU	○	○	×	○	×	○	×
Module access device	Self CPU controlled	○	○	×	○	×	×	×
	Other CPU controlled	○	○	×	○	×	×	×

*1 Writing data is not reflected but an error does not occur.

Operation error

An operation error will occur if:

- (S) to (S)+(n-1) is outside the device range.
- (D) to (D)+(n-1) is outside the device range.
- (n) is 0 or a negative number.
- (S) and (D) combination is wrong.
- (S) and (D) are a CPU buffer memory access device other than the self CPU, or a module access device that is not a self CPU controlled unit.
- (S) is a bit device and the device number is not a multiple of 16
- (D) is a bit device and the device number is not a multiple of 16

Program example

■Program which batch-transfers a contents for 5 words from D0 to all data for 5 words from #10

BMOV #10, D0, K5

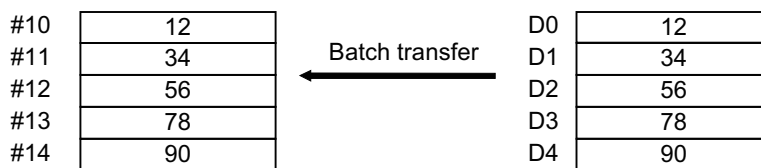

■Program which batch-transfers a contents for 4 words from X0 to all data for 4 words from #20

BMOV #20, X0, K4

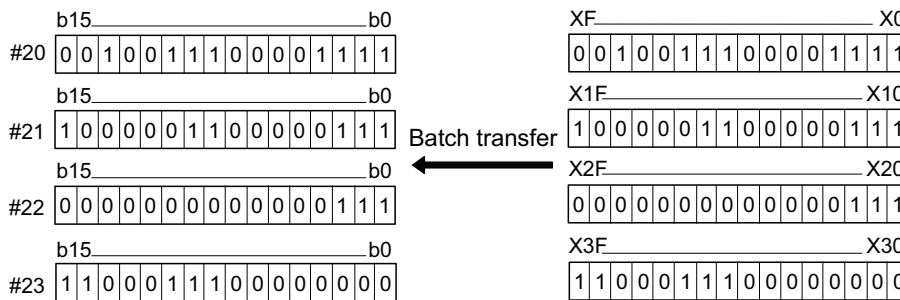

Same data block transfer: FMOV

Format	Number of basic steps	Usable steps	
		F/FS	G
FMOV(D), (S), (n)	12	○	○

Setting data

■ Usable data

○: Usable

Setting data	Usable Data									
	Bit device	Word device			Constant			Calculation expression	Bit conditional expression	Comparison conditional expression
		16-bit integer type	32-bit integer type (L)	64-bit floating point type (F)	16-bit integer type (K/H)	32-bit integer type (K/H, L)	64-bit floating point type (K)			
(D)	○	○	—	—	—	○	—	—	—	—
(S)	○	○	—	—	○	—	—	—	—	—
(n)	—	○	○	—	○	○	—	—	—	—

■ Description, data type of result

Setting data	Description	Data type of result
(D)	Transfer destination device starting No.	—
(S)	Device No. which transfer data or data to be transferred are stored.	
(n)	Number of words to be transferred (1 to 1000000000)	

Processing details

- The data specified with (S) or contents of device are transferred a part for (n) words of data to the device specified with (D).
- Adjust an executive task, the number of transfer word referring to the operation processing time so that this instruction may not obstruct the execution of the motion operation because processing time becomes long in argument to the number of words (n) to be written.

Operation error

An operation error will occur if:

- (D) to (D)+(n-1) is outside the device range.
- (n) is 0 or a negative number.
- (D) is a CPU buffer memory access device other than the self CPU, or a module access device that is not a self CPU controlled unit.
- (S) is a bit device and the device number is not a multiple of 16.
- (D) is a bit device and the device number is not a multiple of 16.

Program example

■ Program which sets 3456H to all data for 100 words from #10

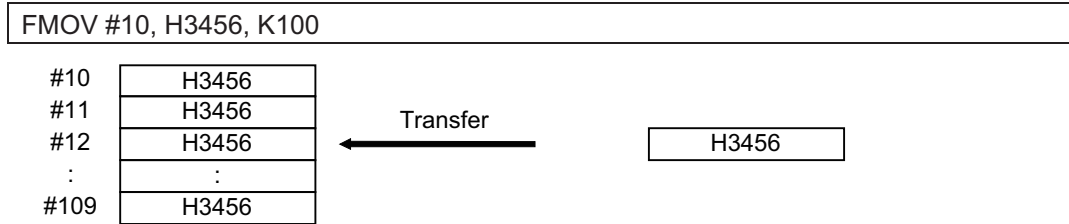

■ Program which sets a content of D4000 to all data for 50 words from W0

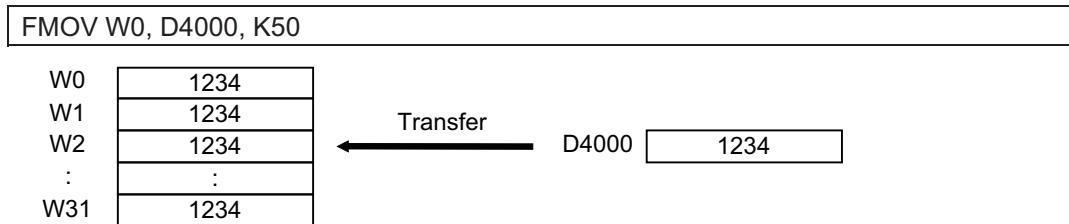

■ Program which sets 8000H to all data for 4 words from M0

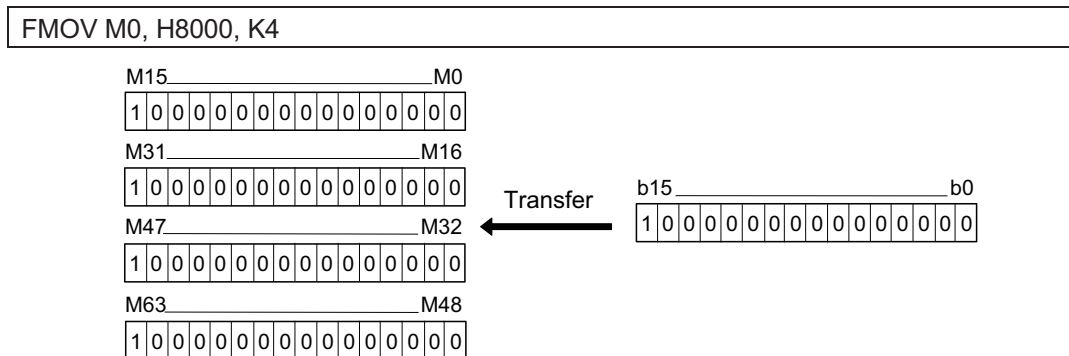

Write device data to buffer memory: TO

Format	Number of basic steps	Usable steps	
		F/FS	G
TO(D1), (D2), (S), (n)	14	○	○

Setting data

Usable data

○: Usable

Setting data	Usable Data								Calculation expression	Bit conditional expression	Comparison conditional expression
	Bit device	Word device			Constant						
		16-bit integer type	32-bit integer type (L)	64-bit floating point type (F)	16-bit integer type (K/H)	32-bit integer type (K/H, L)	64-bit floating point type (K)				
(D1)	—	○	—	—	○	—	—	—	—	—	
(D2)	—	○	○	—	○	○	—	—	—	—	
(S)	○	○	—	—	—	—	—	—	—	—	
(n)	—	○	○	—	○	○	—	—	—	—	

Description, data type of result

Setting data	Description	Data type of result
(D1)	First I/O No. of the module (000H to FF0H, 3E00H to 3E30H)	—
(D2)	First address of the buffer memory which writes data. (0 to end of target module buffer memory)	
(S)	Start device No. which writing data are stored.	
(n)	Number of words to be written (1 to within range of target module buffer memory)	

Processing details

- (n) words of data from the device specified with (S) are written to the address specified with (D2) and after of the buffer memory in the specified with (D1).

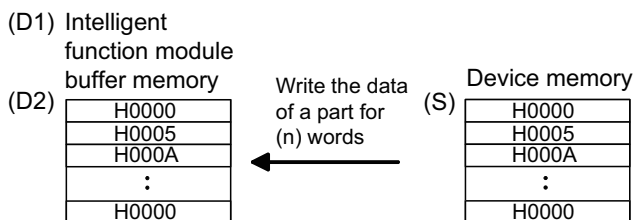

Point

Writing device data can be performed with the module access device (U□\G).

(Example)

Writing 2 words from #0 to buffer memory address 0H of intelligent function module (start I/O number: 010H).

```
U1\G0L = #0L
```

Refer to the following for details of module access device.

📖 MELSEC iQ-R Motion Controller Programming Manual (Common)

- First I/O No. of the module set by [System Parameter] ⇒ [I/O Assignment Setting] in GX Works3 is specified by (D1). (D1) sets 20H by the system configuration when a TO instruction is executed in the D/A conversion module (R64DA).

Power supply module	R04CPU	R32MTCPU	RX40C7	R64AD	R64DA
	First I/O No. No. : 3E00H	First I/O No. No. : 3E10H	First I/O No. No. : 00H	First I/O No. No. : 10H	First I/O No. No. : 20H

- The upper limit for the value that can be set for number of words (n) to be written and buffer memory start address (D2) differs depending on the target module. Refer to the manual of module used for details.
- Adjust an executive task, the number of words (n) to be written referring to the operation processing time so that this instruction may not obstruct the execution of the motion operation because processing time becomes long in argument to the number of words (n) to be written.
- Refer to the following for intelligent function modules that can be used as the Motion CPU control module.
 - 📖 MELSEC iQ-R Motion controller Programming Manual (Common)
- The combinations for write destination and write source that are set to (S) and (D1) are shown below.

○: Combination possible, ×: Combination not possible

Write source (S)		Write destination (D1)			
		CPU start I/O number (3E00H to 3E30H)		Module start I/O number (000H to FF0H)	
		Self CPU	Other CPU	Self CPU controlled	Other CPU controlled
User device/System device		○	×	○	×
CPU buffer memory access device	Self CPU	○	×	○	×
	Other CPU	○	×	×	×
CPU buffer memory access device (fixed scan communication area)	Self CPU	○	×	○	×
	Other CPU	○	×	○	×
Module access device	Self CPU controlled	○	×	×	×
	Other CPU controlled	○	×	×	×

Operation error

An operation error will occur if:

- Number of words (n) to be written is outside the range.
- Motion CPU cannot communicate with target module at the instruction execution.
- Abnormalities of the target module were detected at the instruction execution.
- The address specified with (D2) is outside the buffer memory range.
- Start device No. (S) which writing data are stored + number of words (n) to be written is outside the device range.
- (S) is a bit device and the device number is not a multiple of 16.
- (S) and (D1) combination is wrong.

Program example

■ 2 words from #0 are written to buffer memory address 0H of the intelligent function module (First I/O No.: 010H)

TO H010, H0, #0, K2

Intelligent function module
(First I/O No.: 010H)

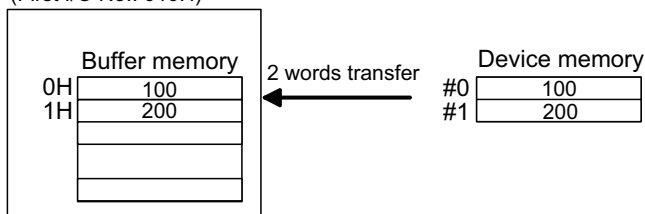

Read device data from buffer memory: FROM

Format	Number of basic steps	Usable steps	
		F/FS	G
FROM(D), (S1), (S2), (n)	14	○	○

Setting data

Usable data

○: Usable

Setting data	Usable Data									
	Bit device	Word device			Constant			Calculation expression	Bit conditional expression	Comparison conditional expression
		16-bit integer type	32-bit integer type (L)	64-bit floating point type (F)	16-bit integer type (K/H)	32-bit integer type (K/H, L)	64-bit floating point type (K)			
(D)	○	○	—	—	—	—	—	—	—	—
(S1)	—	○	—	—	○	—	—	—	—	—
(S2)	—	○	○	—	○	○	—	—	—	—
(n)	—	○	○	—	○	○	—	—	—	—

Description, data type of result

Setting data	Description	Data type of result
(D)	Start device No. which stores the reading data.	—
(S1)	First I/O No. of the module (000H to FF0H, 3E00H to 3E30H)	
(S2)	First address of the buffer memory which it will be read. (0 to end of target module buffer memory)	
(n)	Number of words to be read (1 to within range of target module buffer memory)	

Processing details

- (n) words of data are read from the address specified with (S2) of the buffer memory in the module specified with (S1), and are stored since the device specified with (S2).

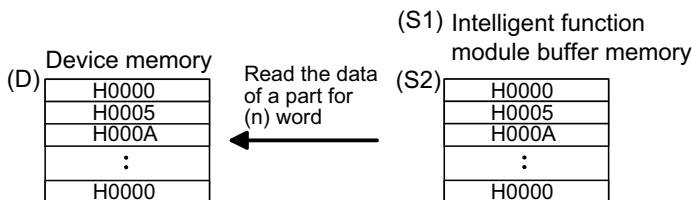

Point

Writing device data can be performed with the module access device (U□\G).

(Example)

Reading 1 word of data from buffer memory address 10H of intelligent function module (start I/O number: 020H), and storing in W0.

```
W0 = U2\G16
```

Refer to the following for details of module access device.

MELSEC iQ-R Motion Controller Programming Manual (Common)

- First I/O No. of the module set by [System Parameter] ⇒ [I/O Assignment Setting] in GX Works3 is specified by (S1). (S1) sets 10H by the system configuration when a FROM instruction is executed in the A/D conversion module (R64AD).

Power supply module	R04CPU First I/O No. No. : 3E00H	R32MTCPU First I/O No. No. : 3E10H	RX40C7 First I/O No. No. : 00H	R64AD First I/O No. No. : 10H	R64DA First I/O No. No. : 20H	
---------------------	-------------------------------------	---------------------------------------	-----------------------------------	----------------------------------	----------------------------------	--

- The upper limit for the value that can be set for number of words (n) to be read, and buffer memory start address (D2) differs depending on the target module. Refer to the manual of module used for details.
- Adjust an executive task, the number of words (n) to be read referring to the operation processing time so that this instruction may not obstruct the execution of the motion operation because processing time becomes long in argument to the number of words (n) to be read.
- Refer to the following for intelligent function modules that can be used as the Motion CPU control module.
 MELSEC iQ-R Motion controller Programming Manual (Common)
- The combinations for read destination and read source that are set to (S1) and (D) are shown below.

○: Combination possible, ×: Combination not possible

Read source(S1)		Read destination(D)						
		User device/ System device	CPU buffer memory access device		CPU buffer memory access device (fixed scan communication area)		Module access device	
			Self CPU	Other CPU	Self CPU	Other CPU	Self CPU controlled	Other CPU controlled
User device/System device		○	○	×	○	× ^{*1}	○	×
CPU start I/O number (3E00H to 3E30H)	Self CPU	○	○	×	○	× ^{*1}	○	×
	Other CPU	○	○	×	○	× ^{*1}	×	×
Module start I/O number (000H to FF0H)	Self CPU controlled	○	○	×	○	× ^{*1}	×	×
	Other CPU controlled	○	○	×	○	× ^{*1}	×	×

*1 Reading data is not reflected but an error does not occur.

Operation error

An operation error will occur if:

- Number of words (n) to be read is outside the range.
- Motion CPU cannot communicate with target module at the instruction execution.
- Abnormalities of the target module were detected at the instruction execution.
- The address specified with (S2) is outside the buffer memory range.
- Start device No. (D) which stores the reading data + number of words (n) to be read is outside the device range.
- (D) is a bit device and the device number is not a multiple of 16.
- (S1) and (D) combination is wrong.

Program example

- 1 word is read from the buffer memory address 10H of the intelligent function module (First I/O No.: 020H), and is stored in W0

```
FROM W0, H020, H10, K1
```

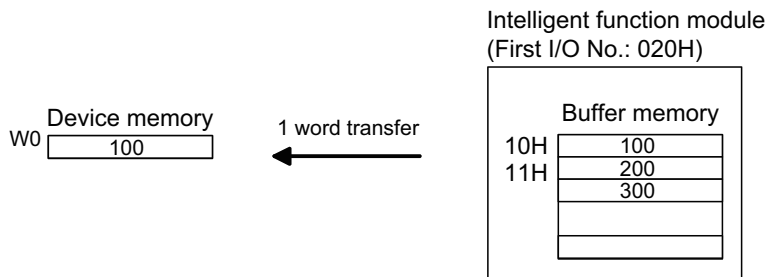

Write buffer memory data to head module: RTO

Format	Number of basic steps	Usable steps	
		F/FS	G
RTO(D1), (D2), (D3), (S), (n), (D4)	21	○	○

Setting data

■ Usable data

○: Usable

Setting data	Usable Data								Calculation expression	Bit conditional expression	Comparison conditional expression
	Bit device	Word device			Constant						
		16-bit integer type	32-bit integer type (L)	64-bit floating point type (F)	16-bit integer type (K/H)	32-bit integer type (K/H, L)	64-bit floating point type (K)				
(D1)	—	○	—	—	○	—	—	—	—	—	
(D2)	—	○	—	—	○	—	—	—	—	—	
(D3)	—	○	—	—	○	—	—	—	—	—	
(S)	○	○	—	—	—	—	—	—	—	—	
(n)	—	○	—	—	○	—	—	—	—	—	
(D4)	○	—	—	—	—	—	—	—	—	—	

■ Description, data type of result

Setting data	Description	Data type of result
(D1)	RIO Axis No. of the target SSCNETⅢ/H head module (601 to 608)	—
(D2)	First I/O No. of the intelligent function module which writes data. (00 to FEH: First 2 digits when I/O No. is 3 digits)	—
(D3)	First address of the buffer memory of the intelligent function module which writes data.	—
(S)	Start device No. which writing data are stored.	—
(n)	Number of words to be written (1 to 32767)	—
(D4)	Complete devices (D4+0): Self CPU device is made to turn ON by the writing completion. (D4+1): Self CPU device is made to turn ON by the writing abnormal completion. ("D4+0" also turns ON at the abnormal completion)	—

Processing details

- (n) words of data from the device specified with (S) are written to the address specified with (D3) and after of the buffer memory in the intelligent function module specified with (D2). The intelligent function module is mounted to the target SSCNETⅢ/H head module specified with (D1). After writing completion of the device data, the complete bit device specified with (D4) turns ON.

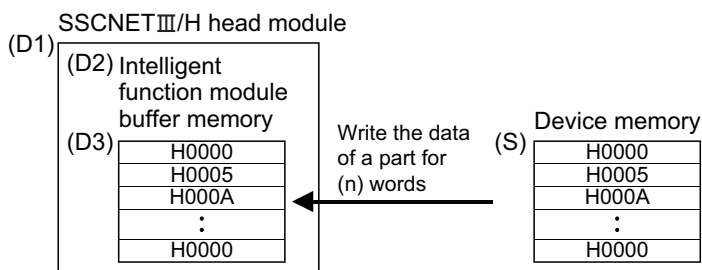

- First I/O No. of the module mounted to the SSCNETIII/H head module set by [Motion CPU Common Parameter] ⇒ [Head Module] is specified by (D2). (D2) sets 05H by the system configuration when a RTO instruction is executed in the D/A conversion module (L60DA4).

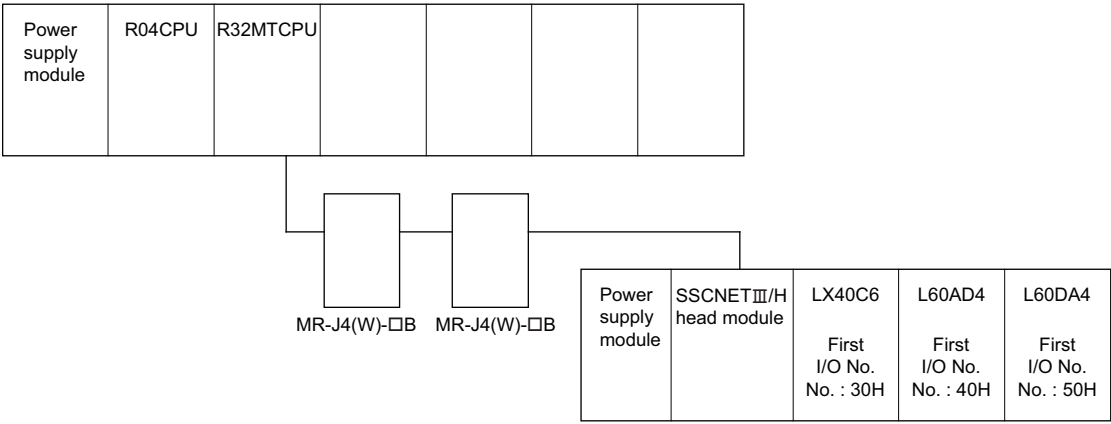

- Adjust an executive task, the number of words (n) to be written referring to the operation processing time so that this instruction may not obstruct the execution of the motion operation because processing time becomes long in argument to the number of words (n) to be written.
- The following modules can be used.

Module	Model
Analogue input	L60AD4, L60AD4-2GH
Analogue output	L60DA4
High-speed counter	LD62, LD62D

- Do resetting of the complete bit device by the user program.
- Another RTO instruction cannot be processed until RTO instruction is executed and a complete bit device is turned ON. When RTO instruction is executed again, before RTO instruction is executed and complete bit device is turned ON, the RTO instruction executed later becomes an error.
- To write 3 words or more of data to the SSCNETIII/H head module, 2 words of writing data are written each time and then repeated. This means that data specified with 3 words or more is not written at the same timing. For data that needs to be written at the same timing use the refresh of the cyclic transmission of the SSCNETIII/H head module word device (Buffer memory of SSCNETIII/H head module and intelligent function module). Refer to the following for details.

📖 MELSEC-L SSCNETIII/H Head Module User's Manual

Operation error

An operation error will occur if:

- Number of words (n) to be written is outside the range.
- The target SSCNETIII/H head module RIO axis No. specified with (D1) is outside the range of 601 to 608.
- The target SSCNETIII/H head module is not connected at instruction execution.
- Start device No. (S) which writing data are stored + number of words (n) to be written is outside the device range.
- (S) is a bit device and the device number is not a multiple of 16.
- RTO instruction was executed again before the RTO instruction is executed and complete bit device is turned ON.
- RTO instruction was executed for the RIO axis of the sensing module.

Abnormal completion (D4+1) of complete device turns ON if:

- Abnormalities of the target SSCNETIII/H head module were detected at the instruction execution.
- First I/O No. of the intelligent function module specified with (D2) differ from the intelligent function module.
- The first address of the buffer memory of the intelligent function module specified with (D3) is outside the buffer memory range.

Program example

- 2 words from #0 are written to buffer memory address 0H of the intelligent function module (First I/O No.: 010H) on the RIO axis 603 of the SSCNET III/H head module

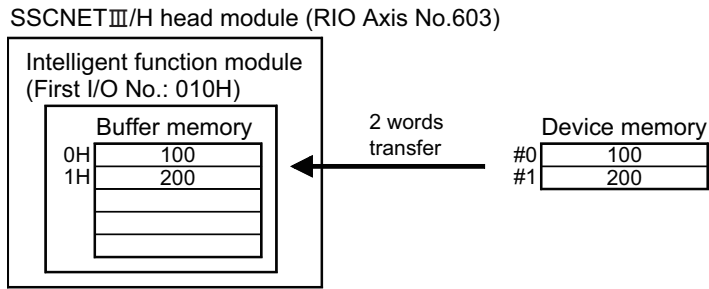
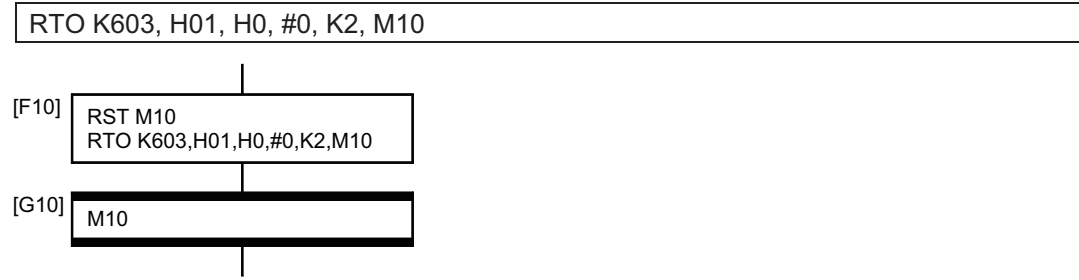

Read buffer memory data from head module: RFROM

Format	Number of basic steps	Usable steps	
		F/FS	G
RFROM(D), (S1), (S2), (S3), (n), (D1)	21	○	○

Setting data

■ Usable data

○: Usable

Setting data	Usable Data									
	Bit device	Word device			Constant			Calculation expression	Bit conditional expression	Comparison conditional expression
		16-bit integer type	32-bit integer type (L)	64-bit floating point type (F)	16-bit integer type (K/H)	32-bit integer type (K/H, L)	64-bit floating point type (K)			
(D)	○	○	—	—	—	—	—	—	—	—
(S1)	—	○	—	—	○	—	—	—	—	—
(S2)	—	○	—	—	○	—	—	—	—	—
(S3)	—	○	—	—	○	—	—	—	—	—
(n)	—	○	—	—	○	—	—	—	—	—
(D1)	○	—	—	—	—	—	—	—	—	—

■ Description, data type of result

Setting data	Description	Data type of result
(D)	Start device No. which stores the reading data.	—
(S1)	RIO Axis No. of the target SSCNETⅢ/H head module (601 to 608)	
(S2)	First I/O No. of the intelligent function module which data to be read are stored. (00 to FEH: First 2 digits when I/O No. is 3 digits)	
(S3)	First address of the buffer memory of the intelligent function module which stores the data to be read.	
(n)	Number of words to be read (1 to 32767)	
(D1)	Complete devices (D1+0): Self CPU device is made to turn ON by the reading completion. (D1+1): Self CPU device is made to turn ON by the reading abnormal completion. ("D1+0" also turns ON at the abnormal completion)	

Processing details

- (n) words of data are read from the address specified with (S3) of the buffer memory in the intelligent function module specified with (S2). The intelligent function module is mounted to the target SSCNETⅢ/H head module specified with (S1). The data is written to device specified with (D) and after.

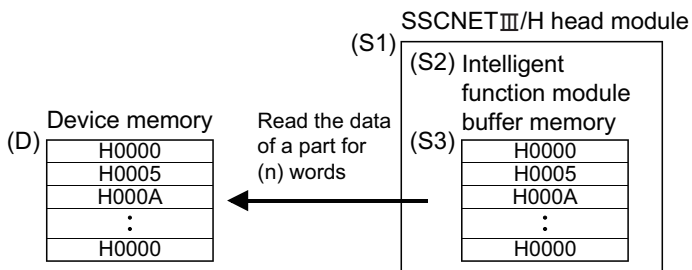

- First I/O No. of the module mounted to the SSCNETⅢ/H head module set by [Motion CPU Common Parameter] ⇒ [Head Module] is specified by (S2). (S2) sets 04H by the system configuration when a RFROM instruction is executed in the A/D conversion module (L60AD4).

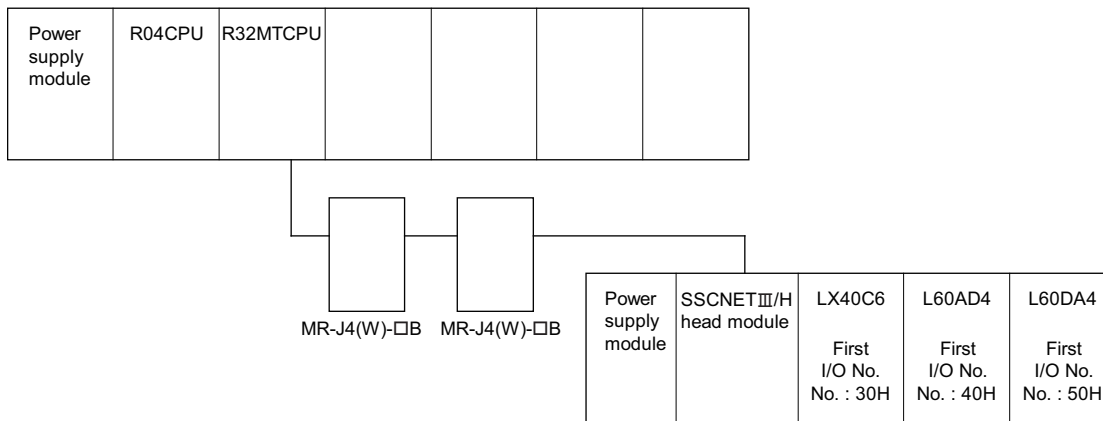

- Adjust an executive task, the number of words (n) to be read referring to the operation processing time so that this instruction may not obstruct the execution of the motion operation because processing time becomes long in argument to the number of words (n) to be read.
- The following modules can be used.

Module	Model
Analogue input	L60AD4, L60AD4-2GH
Analogue output	L60DA4
High-speed counter	LD62, LD62D

- Do resetting of the complete bit device by the user program.
- Another RFROM instruction cannot be processed until RFROM instruction is executed and a complete bit device is turned ON. When RFROM instruction is executed again, before RFROM instruction is executed and complete bit device is turned ON, the RFROM instruction executed later becomes an error.
- To read 5 words or more of data from the SSCNETⅢ/H head module, 4 words of read data are read each time and then repeated. This means that data specified with 5 words or more is not read at the same timing. For data that needs to be read at the same timing use the refresh of the cyclic transmission of the SSCNETⅢ/H head module word device (Buffer memory of SSCNETⅢ/H head module and intelligent function module). Refer to the following for details.

📖 MELSEC-L SSCNETⅢ/H Head Module User's Manual

Operation error

An operation error will occur if:

- Number of words (n) to be read is outside the range.
- The target SSCNETⅢ/H head module RIO axis No. specified with (S1) is outside the range of 601 to 608.
- The target SSCNETⅢ/H head module is not connected at instruction execution.
- Start device No. (D) which stores the reading data + number of words (n) to be read is outside the device range.
- (D) is a bit device and device number is not a multiple of 16.
- RFROM instruction was executed again before the RFROM instruction is executed and complete bit device is turned ON.
- RFROM instruction was executed for the RIO axis of the sensing module.

Abnormal completion (D1+1) of complete device turns ON if:

- Abnormalities of the target SSCNETⅢ/H head module were detected at the instruction execution.
- First I/O No. of the intelligent function module specified with (S2) differ from the intelligent function module.
- The first address of the buffer memory of the intelligent function module specified with (S3) is outside the buffer memory range.

Program example

- 1 word is read from the buffer memory address 10H of the intelligent function module (First I/O No.: 020H) on the RIO axis 602 of the SSCNET III/H head module, and is stored in W0

```
RFROM W0, K602, H02, H10, K1, M0
```

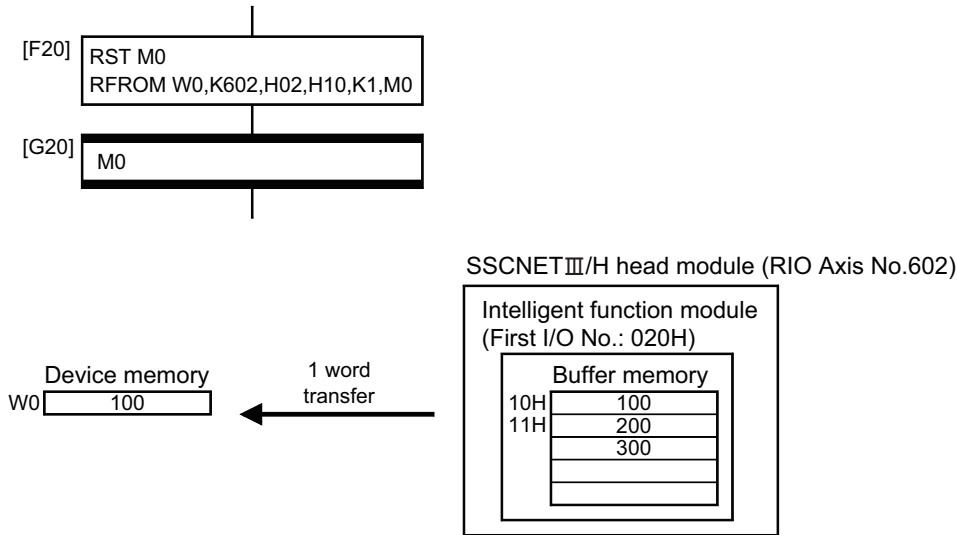

Time to wait: TIME

Format	Number of basic steps	Usable steps	
		F/FS	G
TIME(S)	8	—	○

Setting data

■ Usable data

○: Usable

Setting data	Usable Data									
	Bit device	Word device			Constant			Calculation expression	Bit conditional expression	Comparison conditional expression
		16-bit integer type	32-bit integer type (L)	64-bit floating point type (F)	16-bit integer type (K/H)	32-bit integer type (K/H, L)	64-bit floating point type (K)			
(S)	—	○	○	—	○	○	—	—	—	

■ Description, data type of result

Setting data	Description	Data type of result
(S)	Waiting time (0 to 2147483647)[ms]	Logical type (true/false)

Processing details

- A wait state continues for the time specified with (S). The result is false when the elapsed time is less than the preset time, or the result is true and execution transits when the preset time has elapsed.
- When a 16-bit integer type word device is used to specify any of 32768 to 65535[ms] at (S), convert it into an unsigned 32-bit integer value with ULONG. (Refer to the program example.)

Operation error

An operation error will occur if:

- (S) is an indirectly specified device and its device No. is outside the range.
- The data (device data at indirect specification) specified with (S) is outside the range of 0 to 2147483647.

Program example

■ Program which sets a wait of 60 seconds (when constant is specified)

```
TIME K60000
```

■ Program for a case where there may be a wait of 32768 to 65535 [ms] for 16-bit integer type indirect designation (#0)

```
TIME ULONG(#0)
```

■ Program which SETS (RSTs) a bit device when the specified time has elapsed

```
SET M100 = TIME K60000
```

- When the waiting time setting is indirectly specified with a word device, the value imported first is used as the device value for exercising control. The set time cannot be changed if the device value is changed during a wait state.
- The TIME instruction is equivalent to a conditional expression, and therefore may be set on only the last line of a transition (G) program.
- When the transition program (Gn) of the same number having the TIME instruction setting is used in multiple Motion SFC programs, avoid running them at the same time. (If they are run simultaneously, the waiting time in the program run first will be illegal.)
- Another transition program (Gn) can be executed a time of instruction by multiple Motion SFC programs simultaneously. (Multi active step up to 1024 (for operating system software version "08" or earlier, up to 256).)
- While time by TIME instruction waits, the wait time can not be stopped.

4.20 Comment Statement: //

Format	Number of basic steps	Usable steps	
		F/FS	G
//	—	○	○

Setting data

There are no setting data.

Processing details

A character string from after // to a block end is a comment.

Operation error

There are no operation errors.

Program example

■ Example which has commented a substitution program

```
D0=D1//Substitutes the D0 value (16-bit integer data) to D1.
```

5 TRANSITION PROGRAMS

5.1 Transition Programs

Transition programs

- Substitution operation expressions, motion-dedicated functions, bit device control commands and transition conditions can be set in transition programs.
- Multiple blocks can be set in one transition program.
- There are no restrictions on the number of blocks that may be set in a single transition program. Note that one program is within 128k bytes.
- The maximum number of characters in one block is 1020.
- Transition condition must be set in the last block of a transition program. Transition program is repeated until the transition condition enables, and when the transition condition has enabled, it shifts to the next step. Transition condition can be set only in the last block.
- As a special transition program, a program which only no operation (NOP) is set in one block can be created. This program is used when it is not set as interlock to process to next step with completion of servo program. (Page 108 To proceed to the next step on operation completion)

A transition program example is shown below.

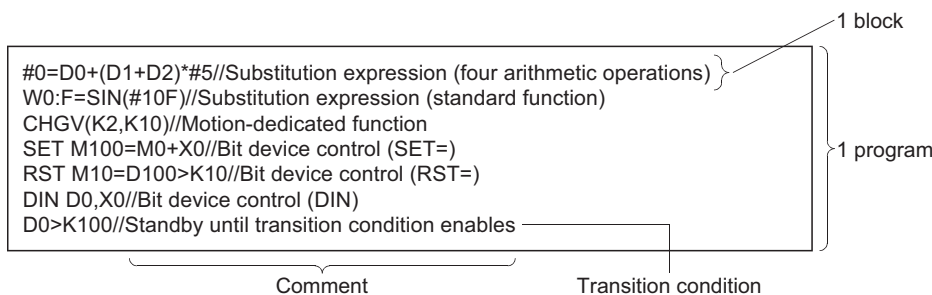

What can be set as a transition condition in the last block are bit conditional expressions, comparison conditional expressions and device set (SET=)/device reset (RST=) which return logical data values (true/false). In the case of device set (SET=)/device reset (RST=), whether the bit or comparison conditional expression specified at (S) is true or false is a transition condition, and when the transition condition enables, device set/reset is executed and execution shifts to the next step. Transition condition description examples are given below.

Classification	Description example
Bit conditional expression	M0
	!M0+X10*M100
Comparison conditional expression	(D0>K100)+(D100L!=K20L)
Device set (SET=)	SET Y0=M100
Device reset (RST=)	RST M10=D0=K100

Point

- A transition program differs from an operation control program in that a transition condition is set in the last block. Other settings are the same as those of the operation control program.
- When setting device set (SET=)/device reset (RST=) in the last block as a transition condition, the bit or comparison conditional expression specified with (S) is not omissible.
- Only the bit or comparison conditional expression cannot be set in other than the last block. Device set (SET=)/device reset (RST=) can be set in other than the last block.

MEMO

6 OPERATION FOR MOTION SFC AND PARAMETER

6.1 Task Definitions

When to execute the Motion SFC program processing can be set only once in the program parameter per program. Roughly classified, there are the following three different tasks.

Task type	Contents
Normal task	Executes in Motion CPU main cycle (free time).
Event task	<ul style="list-style-type: none">• Executes in fixed cycle (0.222ms, 0.444ms, 0.888ms, 1.777ms, 3.555ms, 7.111ms, 14.222ms).• Executes when the input set to the event task factor among external interrupts (16 points of interrupt pointer (I0 to I15)) turns on.• Executes by an interrupt from the PLC CPU.
NMI task	Executes when the input set to the NMI task factor among external interrupts (16 points of interrupt pointer (I0 to I15)) turns on.

Point

- Fixed cycle event task operates regardless of the operation cycle setting.

(Example)

When operation cycle is set to 0.888ms, a 0.222ms fixed cycle event task is executed.

- Set the interrupt pointer (I0 to I15) in the module detailed settings of the Motion CPU controlled input module displayed by the "Detailed" button in [R Series Common Parameter] ⇒ [Module Configuration List] ⇒ "Setting Item"

6.2 Number of Consecutive Transitions and Task Operation

Number of consecutive transitions

With "execution of active step → judgment of next transition condition → transition processing performed when condition enables (transition of active step)" defined as a single basic operation of the Motion SFC program execution control in the execution cycle of the corresponding task, this operation is performed for the number of active steps to terminate processing once. And the same operation is processed continuously in the next cycle. In this case, the transition destination step is executed in the next cycle when the transition condition enables.

Consecutive transition control indicates that transition destination steps are executed one after another in the same one execution cycle when their transition conditions have enabled (single basic operation is performed consecutively). In this case, set the number of consecutive transitions. Control exercised is common to the Motion SFC programs executed by normal tasks.

Point

Set the number of consecutive transitions to the Motion SFC programs executed by event and NMI tasks for every program.

Task operation

Normal task operation

Operations

The Motion SFC program is executed in the main cycle (free time) of the Motion CPU. The processing outline is shown below.

- Number of consecutive transitions is set to "2".

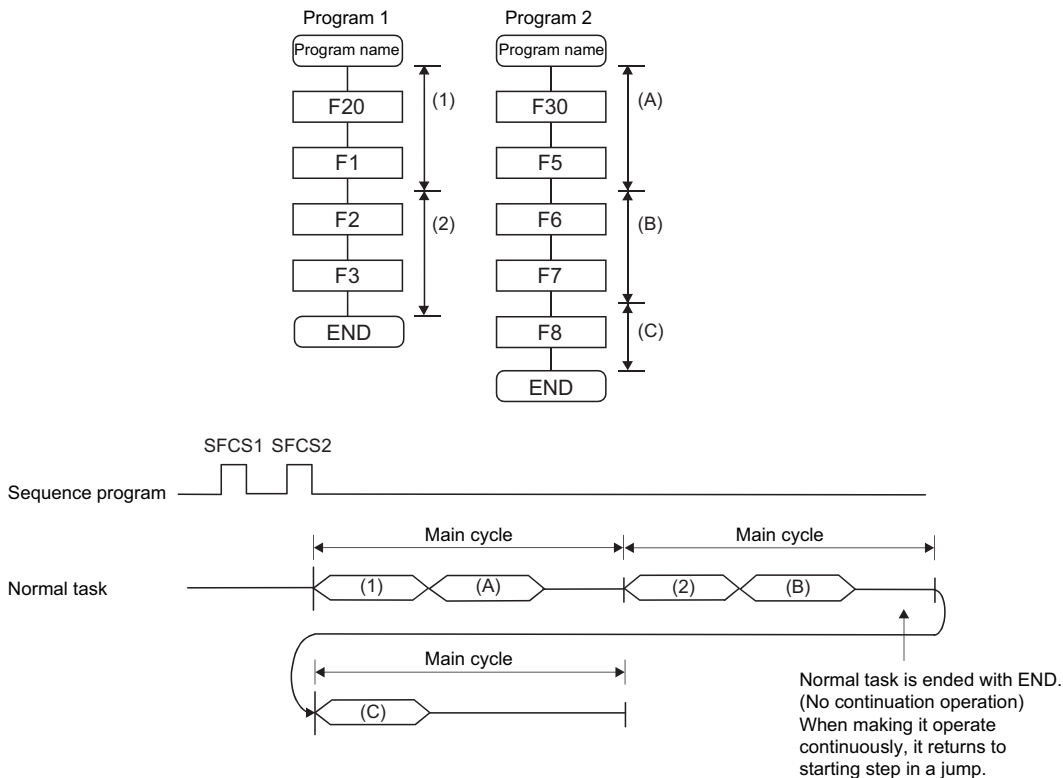

Points

- The Motion SFC program which includes motion control steps should be set to a normal task.
- During execution of an event or NMI task, the execution of the normal task is suspended. Note that since the normal task allows the event task disable instruction (DI) to be described in an operation control step, the event task can be disabled in the area enclosed by the event task disable instruction (DI) and event task enable instruction (EI). The event task enable/disable status can be confirmed with "EI flag (SM752)".

Event task operation

Operations

An event task executes the Motion SFC program at occurrence of an event. There are the following events.

Event	Contents
Fixed cycle	The Motion SFC program is executed periodically in any of 0.222ms, 0.444ms, 0.888ms, 1.777ms, 3.555ms, 7.111ms and 14.222ms cycles.
External interrupt (16 points interrupt pointer (I0 to I15))	Among 16 points of the interrupt pointer (I0 to I15) assigned to the Motion CPU controlled input module, the Motion SFC program is run when the input set for an event task turns on.
PLC interrupt	The Motion SFC program is executed when the M(P).GINT/D(P).GINT instruction is executed in the sequence program.

Ex.

(Example 1)

Operation for fixed cycle task (3.555[ms]) (Number of consecutive transitions is set to "2".)

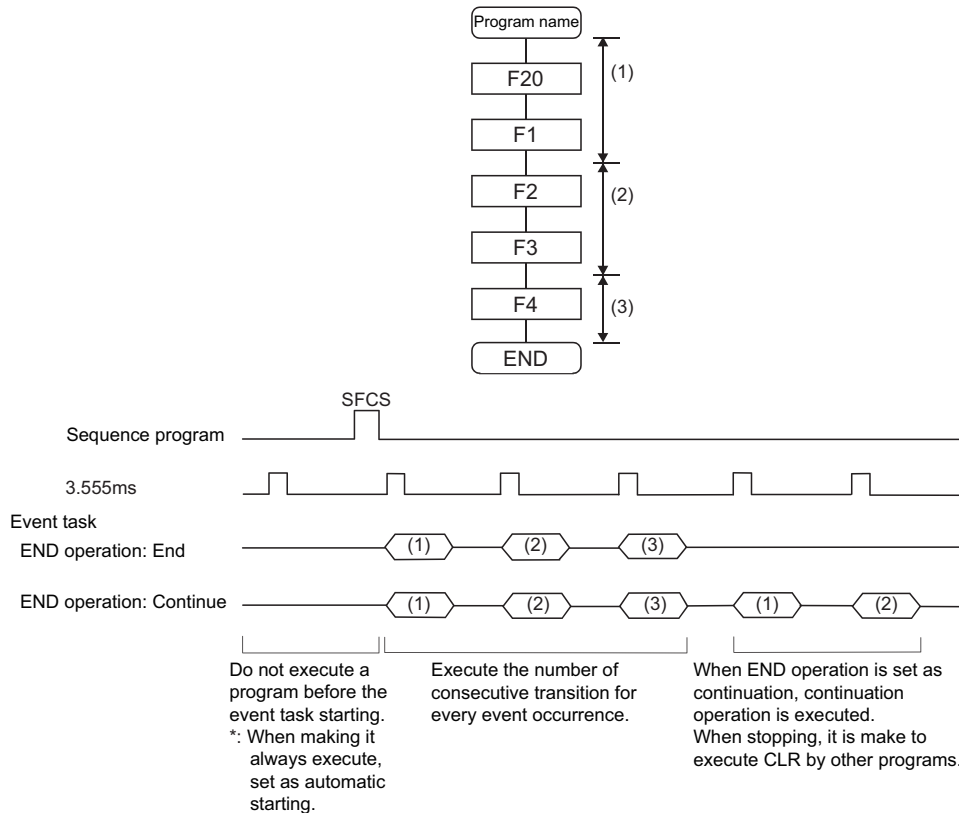

(Example 2)

Operation for PLC interrupt by M(P).GINT/D(P).GINT (Number of consecutive transitions is set to "2".)

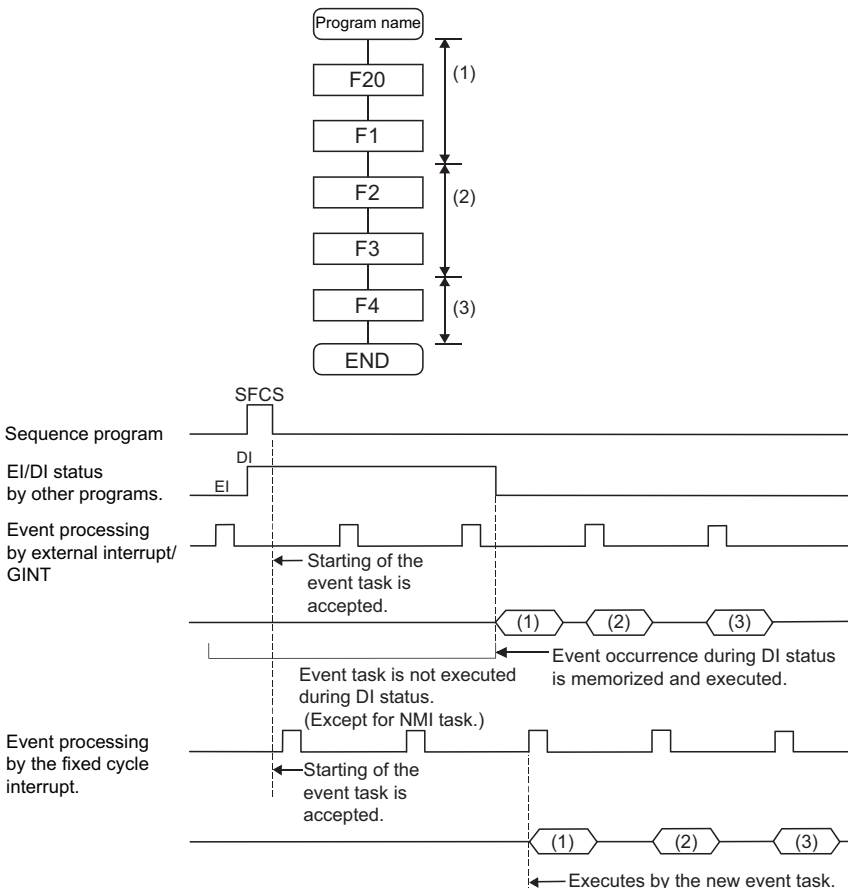

■Points

- Multiple events can be set to one Motion SFC program. However, multiple fixed cycles cannot be set.
- Multiple Motion SFC programs can be executed by one event.
- Motion control steps cannot be executed during the event task.
- The event task cannot be executed when it is disabled by the normal task. The event that occurred during event task disable is executed the moment the event task is enabled.

■Errors

When the motion control step is executed by the Motion SFC program set to the event task, the minor error (SFC) (error code: 33FDH) occurs and stops the Motion SFC program running.

NMI task operation

■Operations

The Motion SFC program is executed when the input set to the NMI task factor among external interrupts (16 points interrupt pointer (I0 to I15) assigned to the Motion CPU controlled input module) turns on.

- Number of consecutive transitions is set to "2".

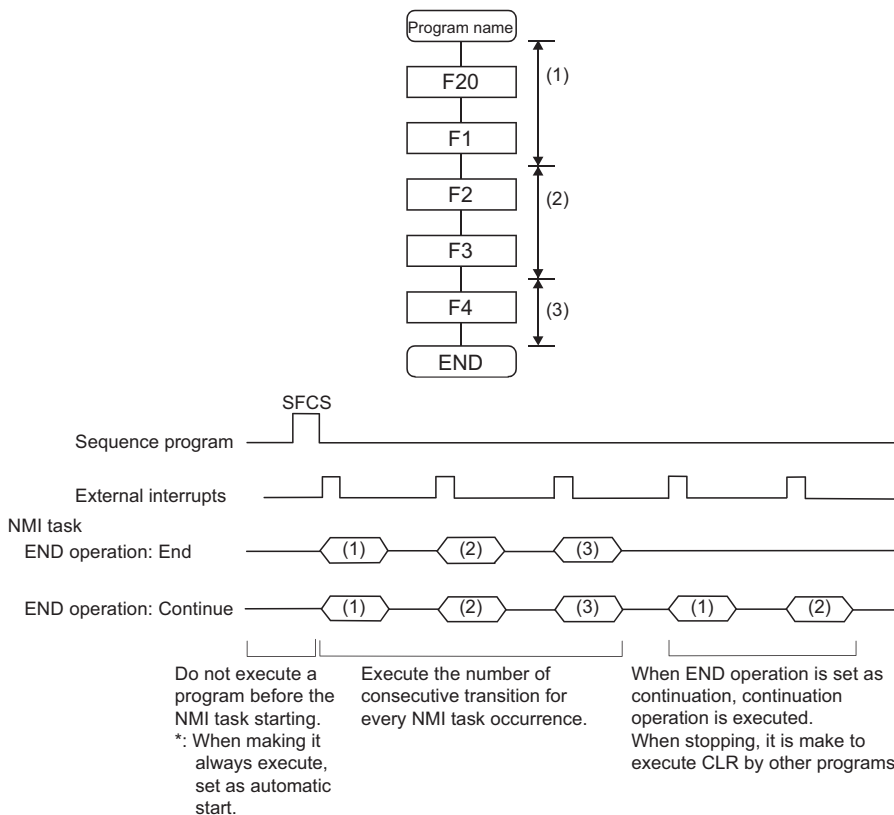

■Points

- NMI task has the highest priority among the normal, event and NMI tasks.
- If the event task is disabled (DI) by the normal task, the interruption of the NMI task is executed, without being masked.
- When parallel branching during NMI task execution, the additional route from the branch starts execution from the next interrupt occurrence.

■Errors

The motion control step is executed during NMI task. If the motion control step is executed during NMI task, the minor error (SFC) (error code: 33FDH) occurs and stops the Motion SFC program.

6.3 Execution Status of the Multiple Task

Executing the Motion SFC program with multiple tasks

Execution status of each Motion SFC program when the Motion SFC program is executed multiple tasks is shown below.

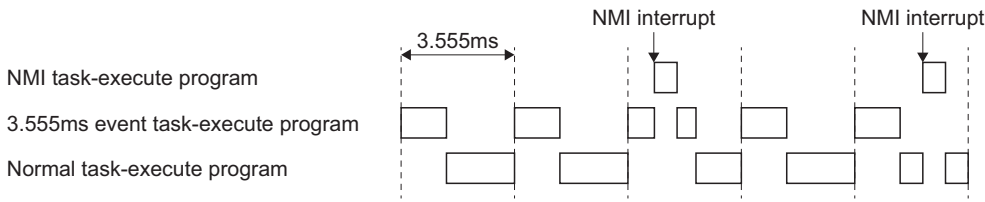

When there are programs which are executed by the NMI task, 3.555ms fixed-cycle even task with a program to run by the NMI task, and the normal task like a chart,

- (1) The 3.555ms fixed-cycle event task is executed at intervals of 3.555ms;
- (2) The NMI task is executed with the highest priority when an NMI interrupt is input; and
- (3) The normal task is executed at free time.

as shown above.

Refer to the following for details of Motion CPU overall process timing that includes Motion operation cycle and main cycle.

📖 MELSEC iQ-R Motion Controller Programming Manual (Common)

■Points

One Motion SFC program can be executed partially by another task by setting the area to be executed by another task as a subroutine and setting a subroutine running task as another task.

Ex.

No. 0 Main Motion SFC program: Normal task

No. 1 Subroutine: Event task (3.555ms cycle)

⚠ CAUTION

- If too many NMI tasks and event tasks are executed, an operation cycle over occurs, or the majority normal tasks are not executed and a WDT error may occur.

When multiple start factors occur within the same type of task

- When another event occurs while executing an event task program, the program that corresponds to the next event is executed after completing the execution for the number of consecutive transitions of the program being executed.

Ex.

When an external interrupt occurs while executing a fixed-cycle event task, the external interrupt task is executed after completing the execution (for the number of consecutive transitions) of the fixed-cycle event task.

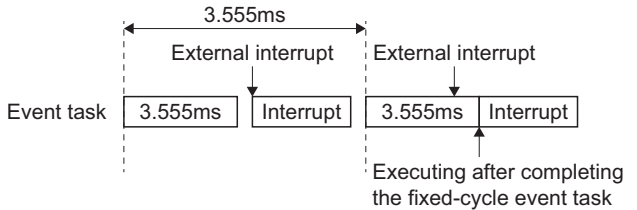

- The following is the operation for when an event task program is being executed and the same event occurs again, or when a NMI task is being executed and a NMI interrupt occurs again.

Task type		Operation when the same event occurs
Event task	Fixed-cycle (0.222ms, 0.444ms, 0.888ms, 1.777ms, 3.555ms, 7.111ms, 14.222ms)	The event afterwards is ignored.
	External interrupt	Executed in order
	PLC interrupt	
NMI	External interrupt	

Ex.

(Example 1)

When the processing time for the process below is executed at a 0.222ms fixed-cycle event task, a 0.3ms process can only be started every 0.444ms.

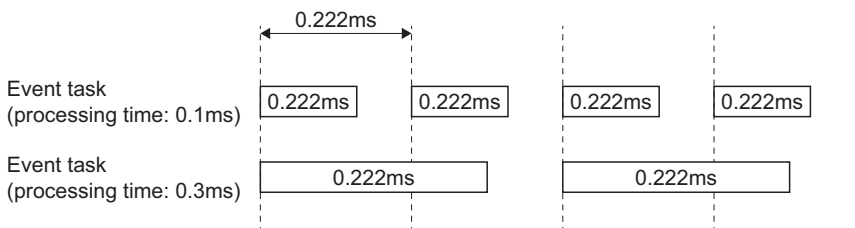

(Example 2)

When a PLC interrupt is issued multiple times, the event task is started in order only for the amount of times issued.

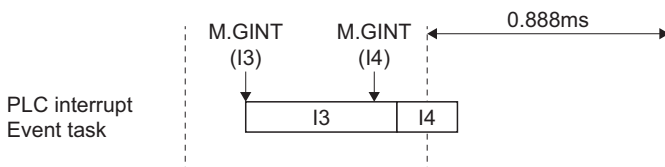

- Fixed-cycle event tasks are executed in the order of the shortest cycle first.

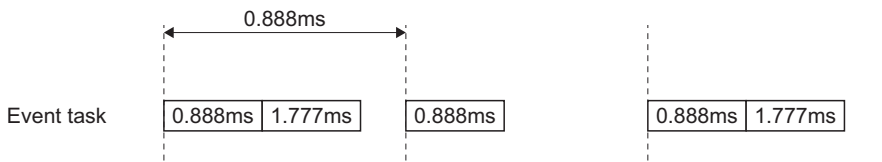

6.4 How to Start the Motion SFC Program

The Motion SFC program is executed during "[Rq.1120] PLC ready flag (R: M30000/Q: M2000)" is on. The Motion SFC program may be started by any of the following three methods. Set the starting method in the program parameter for every Motion SFC program. ( Page 295 Program Parameters)

- Automatic start
- Start from the Motion SFC program
- Start from the Motion dedicated PLC instruction (M(P).SFCS/D(P).SFCS) of other CPU

Automatic start

An automatic start is made by turning "[Rq.1120] PLC ready flag (R: M30000/Q: M2000)" on.

Start from the Motion SFC program

A start is made by executing a subroutine call/start step in the SFC program. ( Page 102 Subroutine call/start step)

Start from the Motion dedicated PLC instruction of other CPU (PLC instruction: M(P).SFCS/D(P).SFCS)

The SFC program is started by executing the M(P).SFCS/D(P).SFCS in the sequence program. ( Page 32 Motion SFC start request from the PLC CPU to the Motion CPU: M(P).SFCS/D(P).SFCS)

6.5 How to End the Motion SFC Program

- The Motion SFC program is ended by executing END set in itself.
- The Motion SFC program is stopped by turning off the "[Rq.1120] PLC ready flag (R: M30000/Q: M2000)".
- The program can be ended by the clear step. (☞ Page 103 Clear step)

Point

Multiple ENDS can be set in one Motion SFC program.

6.6 How to Change from One Motion SFC Program to Another

Use a subroutine start to stop the Motion SFC program running and switch it to another Motion SFC program.

- Motion SFC program changing example using subroutine start

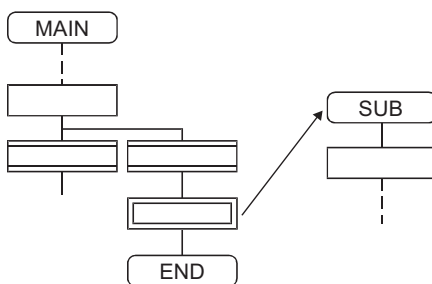

6.7 Operation Performed at Multiple CPU System Power-Off or Reset

When the Multiple CPU system is powered off or reset operation is performed, Motion SFC programs run are shown below.

- When the Multiple CPU system is powered off or reset operation is performed, Motion SFC programs stop to execute.
- At Multiple CPU system power-on or reset, the contents of the devices set to the latch range are held. Initialize them in the Motion SFC programs as required.
- After Multiple CPU system power-off or reset processing, Motion SFC programs run is shown below.
 - The SFC programs set to start automatically are run from the beginning by turning "[Rq.1120] PLC ready flag (R: M30000/Q: M2000)" on in the sequence program.
 - The other Motion SFC programs are also executed from the first at starting.
- During the occurrence of a momentary power failure of the Multiple CPU system power supply, the execution of Motion SFC programs continues.

6.8 Task Parameters

Item		Setting item	Initial value	Remark
Number of consecutive transitions	Normal task (Normal task common)	1 to 30	3	These parameters are imported at leading edge of "[Rq.1120] PLC ready flag (R: M30000/Q: M2000)" and used for control thereafter. When setting/changing the values of these parameters, turns the "[Rq.1120] PLC ready flag (R: M30000/Q: M2000)" off.
Interrupt setting		Set whether the event task or NMI task is used for external interrupt inputs (I0 to I15).	Event task	
Limited count for repeat control	Normal task	1 to 100000	1000	
	Event task	1 to 10000	100	
	NMI task	1 to 10000	100	

Number of consecutive transitions

■Description

With "execution of active step → judgment of next transition condition → transition processing performed when condition enables (transition of active step)" defined as a single basic operation of the Motion SFC program execution control in the execution cycle of the corresponding task, this operation is performed for the number of active steps to terminate processing once. And the same operation is processed continuously in the next cycle. In this case, the transition destination step is executed in the next cycle when the transition condition enables. Consecutive transition control indicates that transition destination steps are executed one after another in the same one execution cycle when their transition conditions have enabled (single basic operation is performed consecutively). In this case, the number of consecutive transitions can be set. Controls in common to the Motion SFC programs executed by normal tasks.



Set the number of consecutive transitions to the Motion SFC programs executed by event and NMI tasks for every program.

■Errors

These parameters are imported and checked at leading edge of "[Rq.1120] PLC ready flag (R: M30000/Q: M2000)". When the value that was set is outside the setting range, the moderate error (error code: 2220H) will occur and the initial value is used to control.

Interrupt setting

■Description

Set whether interrupt pointer (I0 to I15) assigned to the Motion CPU controlled input module is used as NMI or event task inputs. Setting can be made freely per point. All points default to event tasks.

■Errors

None.

Limited count for repeat control

■Description

Operation control program requires longer processing time if the operation control program or transition program has more repeat control instructions (FOR - NEXT). The longer processing time may cause the increase of main cycle and the operation cycle over in event task/NMI task, which is prevented by setting "Limited count for repeat control". Set "Limited count for repeat control" in every normal task, event task and NMI task.

If the repeat control instruction (FOR - NEXT) is executed over "Limited count for repeat control" in an operation control program or a transition program, a minor error (SFC) (error code: 31F8H) will occur, and the corresponding Motion SFC program No. will stop to execute. For the subroutine called program, the call source program also stops to execute.

The repeat control instruction is executed once when the repeat control is judged to continue at FOR instruction execution (when the condition is true). In the program shown below, each block is executed as the arrow indicates, and the repeat control instruction is executed eight times.

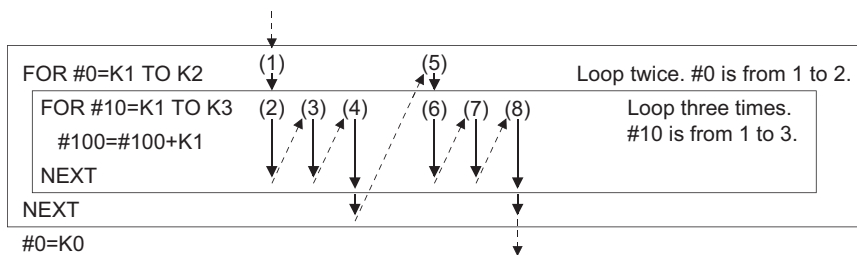

■Errors

None.

These parameters are imported and checked at leading edge of "[Rq.1120] PLC ready flag (R: M30000/Q: M2000)". When the value that was set is outside the setting range, the moderate error (error code: 2220H) will occur.

6.9 Program Parameters

Set the following parameters for every Motion SFC program.

Item	Setting range	Initial value	Remark
Start setting	Automatically started or not	Not setting	These parameters are imported at leading edge of "[Rq.1120] PLC ready flag (R: M30000/Q: M2000)" and used for control there after. When setting/changing the values of these parameters, turn "[Rq.1120] PLC ready flag (R: M30000/Q: M2000)" off.
Execute task	It is only one of normal, event and NMI tasks	Normal task	
	When you have set the event task, further set the event which will be enabled. Always set any one of the following 1 to 3. <ul style="list-style-type: none"> Fixed cycle: It is one of 0.222ms, 0.444ms, 0.888ms, 1.777ms, 3.555ms, 7.111ms and 14.222ms or nothing. External interrupt (make selection from those set to event task): Multiple interrupt can be set from among I0, I1, I2, I3, I4, I5, I6, I7, I8, I9, I10, I11, I12, I13, I14 and I15. PLC interrupt: Multiple interrupt can be set from among I0, I1, I2, I3, I4, I5, I6, I7, I8, I9, I10, I11, I12, I13, I14 and I15. The above: Multiple setting is possible. The same event can be shared among multiple Motion SFC programs.	None	
	When you have set the NMI task, further set the interrupt input which will be enabled. <ul style="list-style-type: none"> External interrupt (make selection from those set to NMI task): Multiple interrupt can be set from among I0, I1, I2, I3, I4, I5, I6, I7, I8, I9, I10, I11, I12, I13, I14 and I15. 		
Number of consecutive transitions	1 to 10 Set the number of consecutive transitions toward the program set to the event or NMI task.	1	
END operation	End/continue Set the operation mode of the END step toward the program set to the event or NMI task.	End	
Executing flag	None/Bit device Set the bit device turned ON while executing Motion SFC program.*1	None	

*1 Refer to the following for the range of bit devices that can be set.
 MELSEC iQ-R Motion Controller Programming Manual (Common)

Point 

The settings of "END operation" are invalid for the subroutine called program. "END operation" is controlled as "end".

Start setting

■Description

The following control is changed by "automatically started or not" setting.

- Program run by normal task

Item	When "automatically started"	When "not automatically started"
Start control	In the main cycle after "[Rq.1120] PLC ready flag (R: M30000/Q: M2000)" ON, the program is executed from the initial (first) step in accordance with the number of consecutive transitions of the normal task.	The program is started by the Motion SFC start request (M(P).SFCS/D(P).SFCS) from other CPU or by a subroutine call/start (GSUB) made from the Motion SFC program. <ul style="list-style-type: none"> • When started by the Motion SFC start request (M(P).SFCS/D(P).SFCS): In the main cycle after execution of the Motion SFC start request (M(P).SFCS/D(P).SFCS), the program is executed from the initial (first) step in accordance with the number of consecutive transitions of the normal task. • When subroutine started: In the (next) main cycle after execution of GSUB, the program is executed from the first step in accordance with the number of consecutive transitions of the normal task. • When subroutine called: The program is executed in the same cycle from the first step.
	After that, the program is executed continuously by the number of consecutive transitions of the normal task in the Motion CPU main cycle. (The settings of "executed task" and "number of consecutive transitions" of the subroutine called program are invalid. It is controlled as the normal task.)	
END control [END]	Ends the self program.	

• Program run by event task

Item	When "automatically started"	When "not automatically started"
Start control	At occurrence of an event after "[Rq.1120] PLC ready flag (R: M30000/Q: M2000)" ON, the program is executed from the initial (first) step in accordance with the number of consecutive transitions of the corresponding program.	<p>The program is started by the Motion SFC start request (M(P).SFCS/D(P).SFCS) from other CPU or by a subroutine call/start (GSUB) made from the Motion SFC program.</p> <ul style="list-style-type: none"> • When started by the Motion SFC start request (M(P).SFCS/D(P).SFCS): At occurrence of an event after execution of the Motion SFC start request (M(P).SFCS/D(P).SFCS), the program is run from the initial (first) step in accordance with the number of consecutive transitions of the corresponding program. • When subroutine started: At occurrence of an event after execution of GSUB, the program is executed from the first step in accordance with the number of consecutive transitions of the corresponding program. • When subroutine called: The program is executed immediately from the first step.
	The program is executed continuously by the number of consecutive transitions of the corresponding program each time an event occurs. (The subroutine called program is controlled in accordance with the "executed task" and "number of consecutive transitions" of the call source program.)	
END control [END]	As specified for END operation.	

• Program run by NMI task

Item	When "automatically started"	When "not automatically started"
Start control	At occurrence of an event after "[Rq.1120] PLC ready flag (R: M30000/Q: M2000)" ON, the program is executed from the initial (first) step in accordance with the number of consecutive transitions of the corresponding program.	<p>The program is started by the Motion SFC start request (M(P).SFCS/D(P).SFCS) from the PLC or by a subroutine call/start (GSUB) made from within the Motion SFC program.</p> <ul style="list-style-type: none"> • When started by Motion SFC start request (M(P).SFCS/D(P).SFCS): At occurrence of an event after execution of Motion SFC start request (M(P).SFCS/D(P).SFCS), the program is run from the initial (first) step in accordance with the number of consecutive transitions of the corresponding program. • When subroutine started: At occurrence of a valid event after execution of GSUB, the program is executed from the first step in accordance with the number of consecutive transitions of the corresponding program. • When subroutine called: The program is executed immediately from the first step.
	The program is executed continuously by the number of consecutive transitions of the corresponding program each time an event occurs.	
END control [END]	As specified for END operation.	

■ Errors

None.

Point 

In the case of the program which is executed by the normal task, write the program so that it is not ended by [END] but it returns to the starting step by a jump when starting of the automatically from an initial again.

Execute task

■Description

Set the timing (task) to execute a program. Specify whether the program will be run by only one of the "normal task (main cycle), event task (fixed cycle, external interrupt, PLC interrupt) and NMI task (external interrupt)".

When the event task is set, multiple events among the "fixed cycle, external interrupt (for event task) and PLC interrupt".

However, multiple fixed cycles cannot be set toward one Motion SFC program.

Ex.

Interrupt setting: Inputs for event task I6, I7, I8, I9, I10, I11, I12, I13, I14 and I15

Motion SFC program No.10 — event: Fixed cycle (3.555ms)

Motion SFC program No.20 — event: Fixed cycle (1.777ms) + external interrupt (I6)

Motion SFC program No.30 — event: External interrupts (I7, I15) + PLC CPU interrupt

When the NMI task is set, multiple interrupt inputs among the external interrupts (for NMI task) can be set.

Ex.

Interrupt setting: Inputs for NMI task I0, I1, I2, I3, I4, I5

Motion SFC program No.10 — NMI: I0

Motion SFC program No.20 — NMI: I1 + I2

Motion SFC program No.30 — NMI: I5

■Errors

This program parameter is imported at leading edge of "[Rq.1120] PLC ready flag (R: M30000/Q: M2000)", and is checked at starting of the Motion SFC program (automatic start, start from PLC or subroutine start). When the value is illegal, a moderate error (error code: 2220H) will occur and it is controlled with initial value.

Point

- Since the execute task can be set for every Motion SFC program No., multiple programs need not be written for single control (machine operation) to divide execution timing-based processing's. It can be achieved easily by subroutine starting the areas to be run in fixed cycle and to be run by external interrupt partially in the Motion SFC program run by the normal task.
- Set a larger fixed cycle than the motion operation cycle after confirming the "Motion operation cycle (SD522)" for the cycle of the event task of the fixed cycle.

Number of consecutive transitions

■Description

Set the number of consecutive transitions to program executed by the event or NMI task for every program.

Refer to the number of consecutive transitions for number of consecutive transitions. ( Page 293 Number of consecutive transitions)

■Errors

This program parameter is imported at leading edge of "[Rq.1120] PLC ready flag (R: M30000/Q: M2000)", and is checked at starting of the Motion SFC program (automatic start, start from PLC or subroutine start). When the value is illegal, a moderate error (error code: 2220H) will occur and it is controlled with initial value.

END operation

■Description

Set the operation at execution of the END step toward the program executed by the event or NMI task. This varies the specifications for the following items.

Item	When "ended"	When "continued"
Control at [END] execution	Ends the self program.	Ends to execute the self program with this event/interrupt.
Restart after [END] execution	Again, the program is started by the Motion SFC start request (M(P).SFCS/D(P).SFCS) from the other CPU or by a subroutine call/start (GSUB) made from the Motion SFC program.	Restarted at occurrence of the next event/interrupt, and run from the initial (first) step in accordance with the number of consecutive transitions of the corresponding program. After that, at occurrence of an event/interrupt, the program is executed in accordance with the number of consecutive transitions of the corresponding program.
Restart after end by clear step [CLR]	Again, the program is started by the Motion SFC start request (M(P).SFCS/D(P).SFCS) from the other CPU or by a subroutine call/start (GSUB) made from the Motion SFC program.	

Point

The END operation of subroutine called program is controlled as an "end".

- The following operation example assumes that the END operation is "continued."

Ex.

Program parameters

Item	Description
Start setting	Automatically started
Execute task	Event task (Fixed-cycle: 3.555ms)
Number of consecutive transitions	2
End operation	Continued

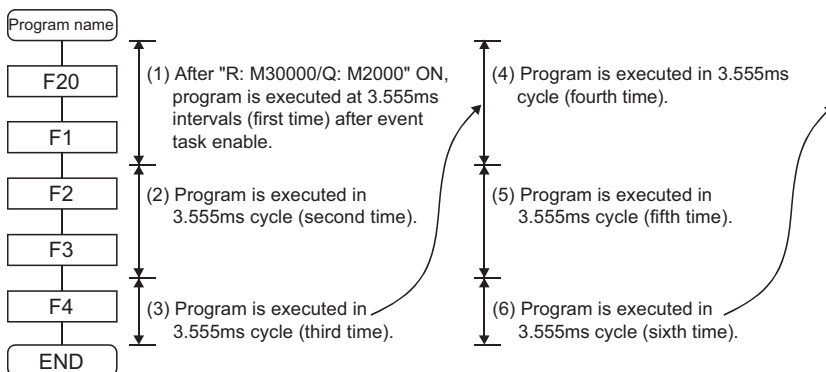

Executing flag

The set bit device turns ON by Motion SFC program start, and it turns OFF by program end.

6.10 Task and Interrupt Processing

In the Motion CPU, the required operations over a fixed cycle are divided into tasks. Depending on the Motion CPU internal processing timing, the interrupt processing can affect tasks, therefore programs need to be designed with care.

Refer to the following for Motion CPU internal processing timing and corresponding processing time monitor devices.

📖 MELSEC iQ-R Motion Controller Programming Manual (Common)

Interrupt Processing

In the Motion CPU, fixed-cycle system processing, Motion SFC fixed-cycle task, and Motion operation processing are executed with priority over main cycle processing. Therefore, if "Motion setting operation cycle (SD523)" is exceeded in the middle of main cycle processing, the main cycle processing is interrupted by the execution of the next Motion operation cycle processing. Main cycle processing restarts when the interrupting Motion operation cycle processing is completed.

Because this interrupt processing is also executed in the middle of operations of the Motion SFC program, depending on the program contents, the Motion SFC program may not execute correctly.

Operation example

Axis 1 of the Motion SFC program below moves to "350.00000[degree]→0[degree]→160.00000[degree]". When the axis 1 feed current value moves in the range of 120.00000 to 130.00000[degree], M100 is turned ON.

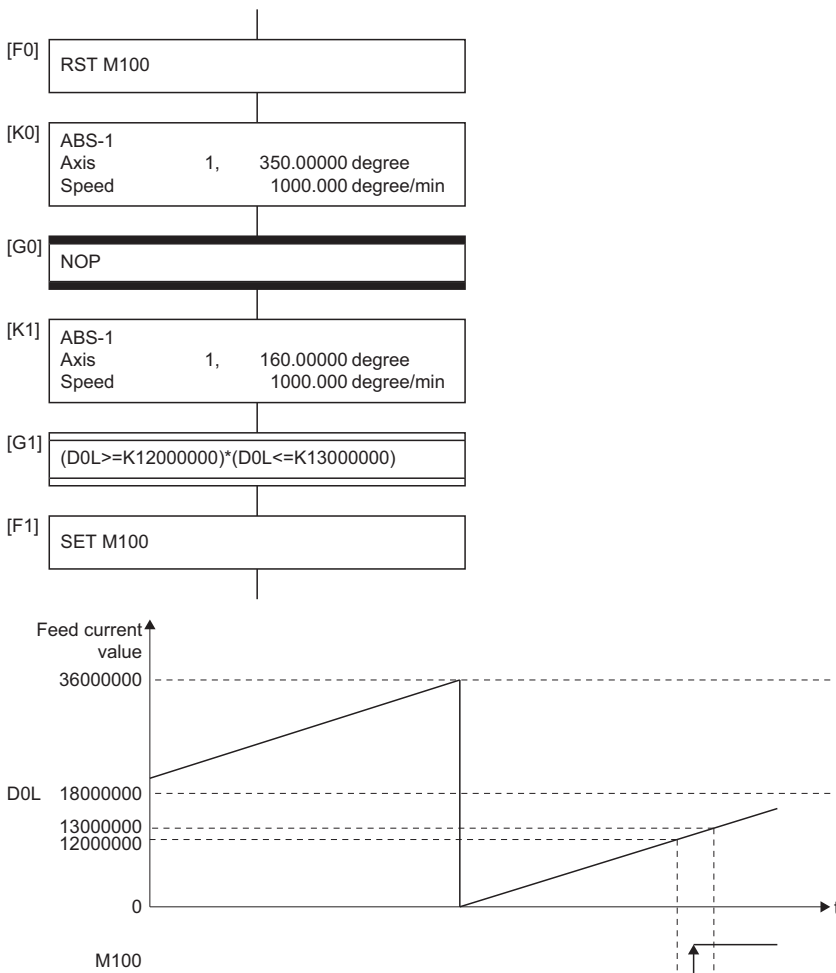

However, when the timing of axis 1 moving from 359.99999[degree] to 0[degree] coincides with the timing of the interrupt execution processing in the middle of [G1] processing in Motion SFC normal task processing, an unintended operation may occur.

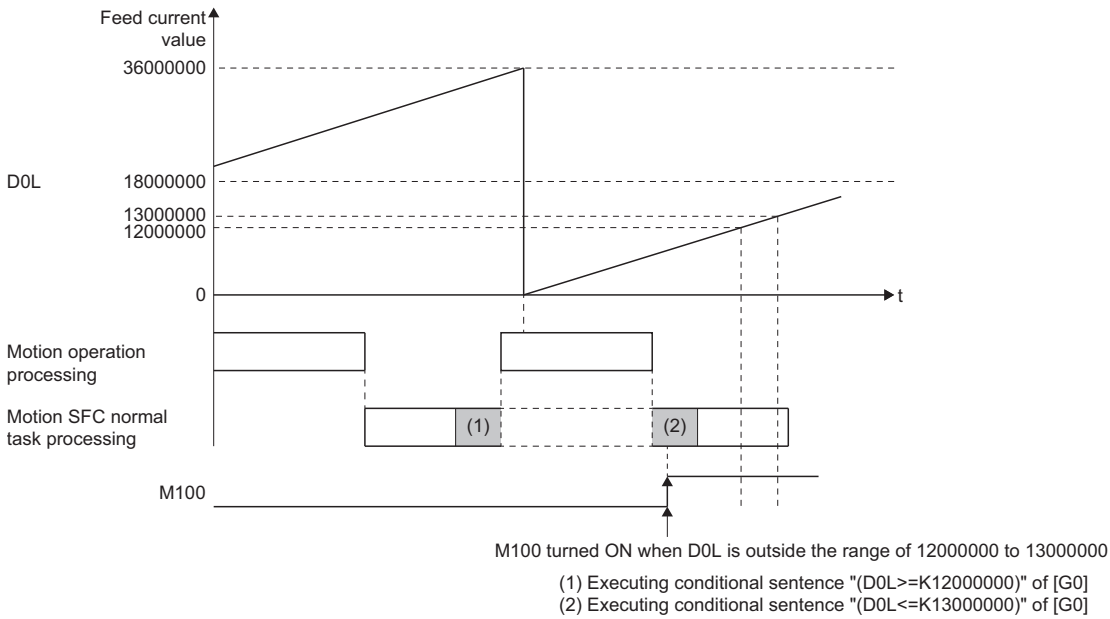

When using the device whose value changes by the Motion operation cycle in a conditional expression, store the value to a device and make the program compare values as shown below.

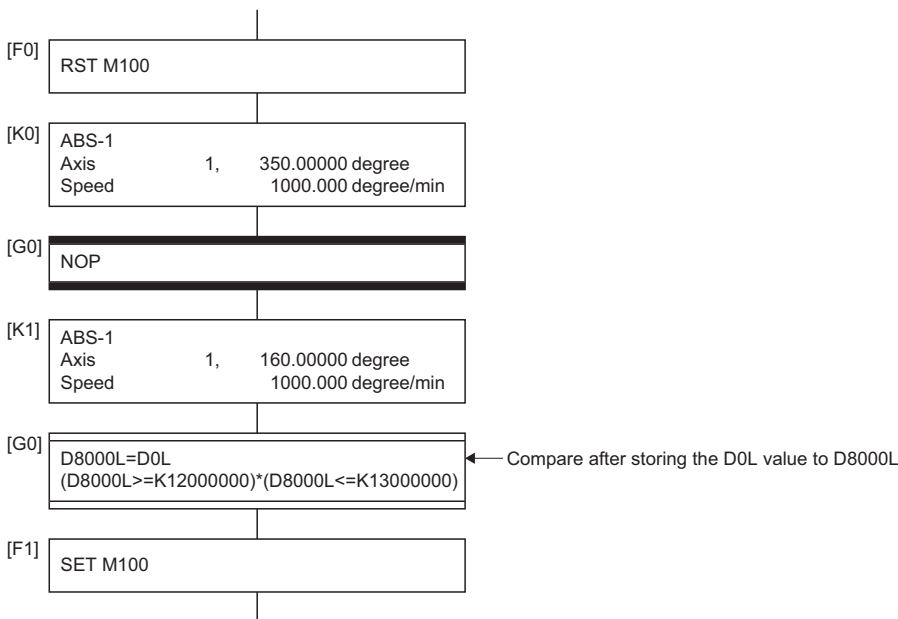

7 MOTION SFC FUNCTIONS

7.1 Online Change in the Motion SFC Program

This function is used to write to the Motion SFC program to the built-in memory of the Motion CPU during the positioning control (during "[Rq.1120] PLC ready flag (R: M30000/Q: M2000)" on). When program correction and check of operation is executed repeatedly, is possible to change program without stopping operation of the Motion CPU. Also, because only the changed part of the Motion SFC program is written, the writing time is short, and the time it takes to debug is shortened. Data in which online change is possible are shown below.

○: Possible, ×: Not possible

Applicable data		Online change	Remarks
R Series Common Parameter		×	
Motion CPU Common Parameter		×	
Motion Control Parameter		×	
Motion SFC program	Motion SFC parameter	×	
	Motion SFC chart	○	Online change is possible for the only program during stop.
	Operation control step (F/FS)	○	
	Transition (G)	○	
	Servo program (K)	○	Online change of mode assignment setting is not possible.
Cam data		×	

Point

- Program writing is executed during the positioning control in the online change. Be safely careful enough for work.
- When a Motion SFC program file, or servo program file is specified in a file transmission at boot that uses a SD memory card, the intended program operation may not occur depending on if there is an online program change file or not. Refer to the following for details.
 MELSEC iQ-R Motion Controller Programming Manual (Common)
- If the online change is executed simultaneously to one Motion CPU from the multiple personal computers, a program writing may not be executed. Please do not perform.
- If online changes are executed by another personal computer during the operation of the monitor mode of the Motion SFC program, debug mode of the Motion SFC program, or test mode in MT Developer2, injustice of a monitor value and operation failure may occur. Please do not perform.
- If the online change of Motion SFC chart added newly is executed, since the online change of Motion SFC parameter cannot be executed, it operates as the normal task (default value).
- When performing an online change by changing the range of the command generation axis program in "Program Allocation Setting" of the servo program editing screen, the changes are not reflected, and online change is cancelled.
- If the cables between the personal computer and PLC CPU module fall out, or the power supply of the Multiple CPU system turns OFF or resets, the program is corrupted. Write the program again by the data writing of MT Developer2.
- The online change only writes when the program being operated by the Motion CPU and the MT Developer2 project data (before change) match. Before writing perform a check, and when data does not match, cancel the online change.

Operating method for the online change

Select the "Online change OFF/ON" with the online change setting screen displayed by selecting [Tools] ⇒ [Online Change Setting] from the MT Developer2 menu bar. The methods for online change of Motion SFC program are shown below.

Target data of online change	Operation for online change
Motion SFC chart	<ul style="list-style-type: none">• Select [Check/Convert] ⇒ [Write Motion SFC Chart] from the menu bar.• Click [Write Motion SFC Chart] of toolbar.
Operation control program (F/FS)	Click [Convert] of operation control program/transition program editor screen.
Transition program (G)	
Servo program (K)	Click [Convert] of servo program editor screen.

Online change of the Motion SFC chart

Online change of the Motion SFC chart in edit is executed by selecting button or menu of toolbar. Online change is possible to the Motion SFC program during stop. If the online change is made to the Motion SFC program during execution, an alarm message indicates. (Execution/stop state of the Motion SFC program can be checked with the program batch monitor.) If the start request is made to the Motion SFC program during online change, the moderate error (error code: 32F7H) will occur and the Motion SFC program does not start.

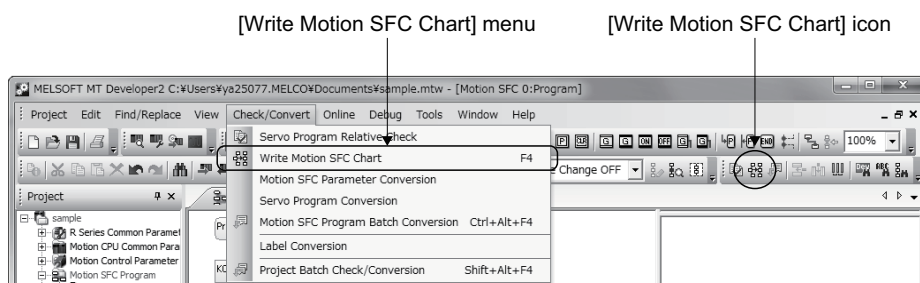

Online change of the operation control/transition program

Online change of the operation control/transition program during edit is executed by selecting the [Convert] button. Online change is possible to the operation control/transition program during execution. A program that the online change was made is executed from the next scan.

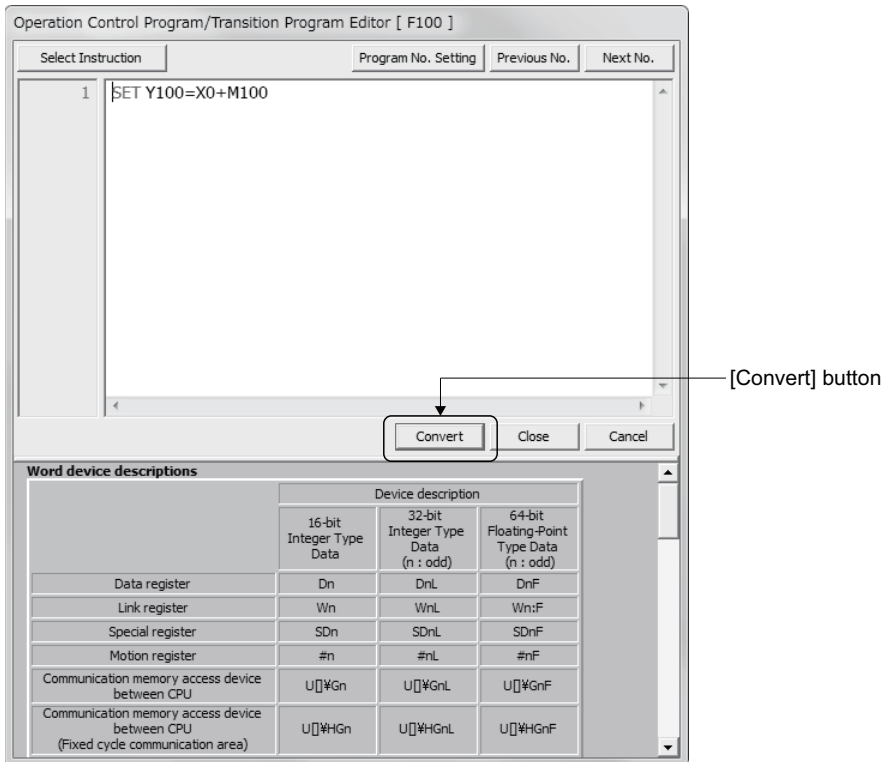

Operations for which made the online change to the operation control/transition program during execution in the following conditions are shown below. Be careful to execute the online change in the following conditions.

Program	Condition	Operation
	Online change of the FSn operation control program is executed during FSn execution in the state of waiting for the completion of condition for Gn.	After completion of online change, the FSn repeats the operation control program that the online change was made until the completion of condition for Gn.
	Online change of the Gn program is executed in the state of waiting for the completion of condition for Gn. (The conditional sentences of program to write are except the TIME instruction.)	After completion of online change, the Gn does not transit to the next step until the completion of condition for program that the online change was made.
	Online change of the Gn program including the TIME instruction is executed in the state of waiting for the completion of condition for Gn.	After completion of online change, Gn is ended regardless of the waiting time of TIME instruction and the next step is executed.
	Online change of the Gn program during the servo program execution for Kn.	After execution of servo program, the program of changed Gn is executed.

Online change of the servo program

Online change of the servo program during edit is executed by selecting the [Convert] button. Online change is possible to the servo program during execution. A program that the online change was made is executed at the next servo program start.

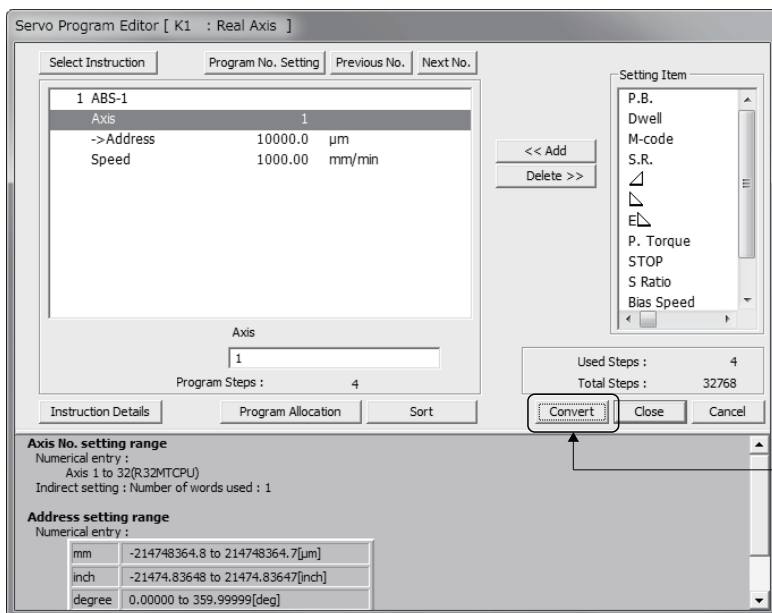

[Convert] button

Operations for which made the online change to the servo program in the following conditions during execution are shown below. Be careful to execute the online change in the following conditions.

Program	Condition	Operation
<pre> graph TD A[ON bit device] --> B[Kn] B --> C[or] C --> D[OFF bit device] D --> E[Kn] </pre>	<p>Online change of the servo program Kn at the WAITON or after WAITOFF is executed in the state of waiting for the completion of condition for WAITON/WAITOFF.</p>	<ul style="list-style-type: none"> • After completion of condition for WAITON/WAITOFF, the servo program before the online change is started. • The servo program that the online change was made is executed at the next servo program start.
<pre> graph TD A[Gn] --> B[Kn] B --> C[or] C --> D[Gn] D --> E[Kn] </pre>	<p>Online change of the servo program Kn after Gn is executed in the state of waiting for the completion of condition for Gn.</p>	<p>After completion of condition for Gn, the servo program that online change was made is executed.</p>

Reading/Writing of program

The outline operations to write the program from MT Developer2 to the program memory of Motion CPU are described.

Operation by MT Developer2

■Reading of program by the reading operation of MT Developer2

If reading of program is performed, all files stored in the program folder and all files stored in the online change folder are read, and a merged program is reflected to the project. (A program configuration is restored in the state that it was being executed in the Motion CPU.)

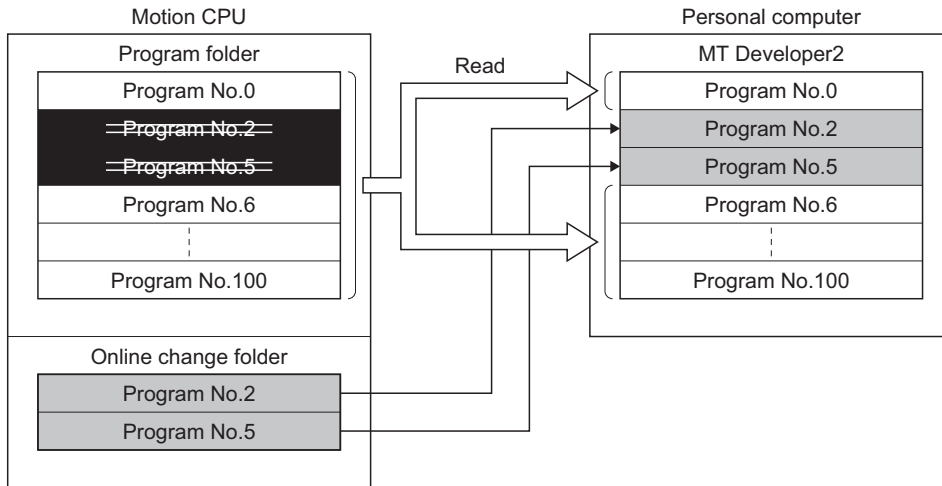

■Writing of program by the writing operation of MT Developer2

If writing of program is performed, the program files are updated and stored in the program folder. Also, when an online change folder exists, the online change folder is deleted.

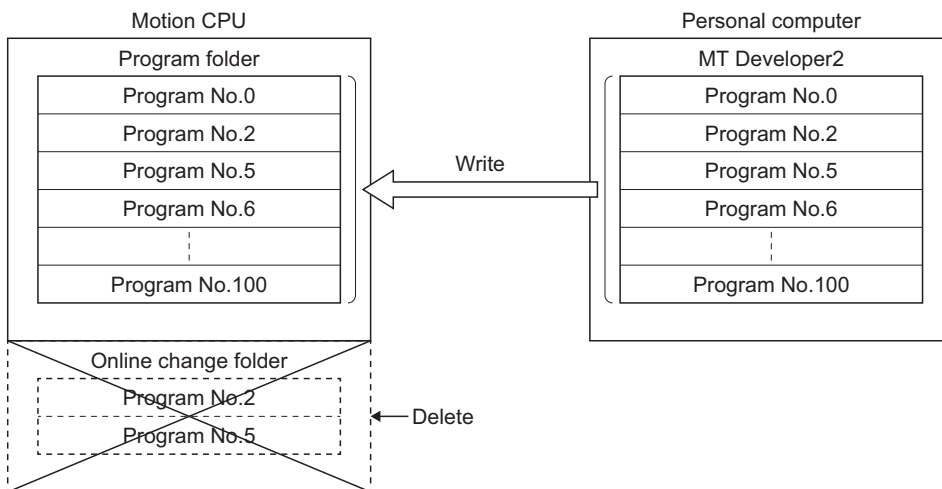

■ Writing of program by the online change operation of MT Developer2

If online change is performed, the new program to execute the online change is stored in the online change folder. (Refer to (1))

After that, the program written in previously is made invalid and the new program is made valid. (Refer to (2))

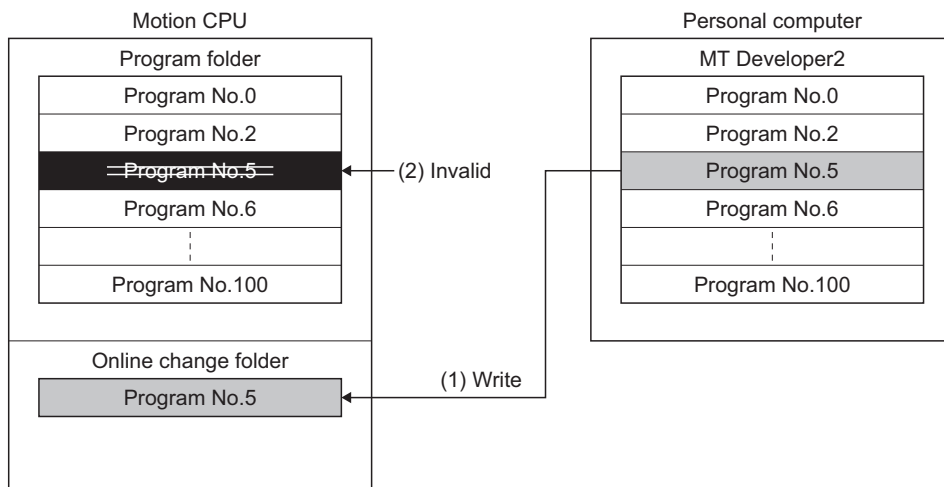

Point

- The files stored in the program folder and the files stored in the online change folder are managed as a set. When a program file in the program folder is the target for file transmission at boot function, the contents of the online change file are also automatically transmitted.
- If the online change is executed repeatedly, the free space in program memory is lost and the online change may not be executed. In this case, write the program by the writing operation of MT Developer2.
(☞ Writing of program by the writing operation of MT Developer2)

Online change when using file transmission at boot function

When a Motion SFC program file, or servo program file is specified in a file transmission at boot that uses a SD memory card, the intended program operation may not occur depending on if there is an online program change file or not. Refer to the following for details.

📖 MELSEC iQ-R Motion Controller Programming Manual (Common)

7.2 Motion SFC Program Monitor and Debug Mode

Motion SFC program monitor

The execution status of Motion SFC programs can be monitored by the Motion SFC program monitor of MT Developer2. The items that can be monitored are shown below. Refer to the following for details of the Motion SFC program monitor.

 Help of MT Developer2

- Execution status list (During execute/During stop/During break)
- Execution status by program (During execute/During stop/During break)
- Active status (Active/Waiting for parallel coupling)

Program executing information can also be checked with special relays (SM), and special registers (SD). Refer to the following for details.

 MELSEC iQ-R Motion Controller Programming Manual (Common)

- Program execution time
- EI/DI status

Debug mode

Operation can be checked by placing a break (stop) in any given part of the Motion SFC program, and executing one step in debug mode. The operations in debug mode are as follows. Refer to the following for details of debug mode.

 Help of MT Developer2

- Break point setting (valid/invalid, number of break points)
- Forced break
- One step execution
- Forced transition
- Forced program end

During debug mode "[St.1041] Motion SFC debugging flag (R: M30038/Q: M2038)" is turned ON.

APPENDICES

Appendix 1 Processing Times

Processing time of operation control/Transition instruction

The processing time for the individual instructions are shown below.

Operation processing times can vary substantially depending on the nature of the source and destinations of the instructions, and the values contained in the following tables should therefore be taken as a set of general guidelines to processing time rather than as being strictly accurate.

Operation instructions

Classifications	Symbol	Instruction	Operation expression	Unit [μ s]
Binary operation	=	Substitution	#0=#1	1.5
			D800=D801	1.5
			U3E1\G10000=U3E1\G10001	2.0
			U3E1\HG10000=U3E1\HG10001	1.8
			#0L=#2L	1.5
			D800L=D802L	1.5
			U3E1\G10000L=U3E1\G10002L	2.0
			U3E1\HG10000L=U3E1\HG10002L	1.8
			#0F=#4F	1.5
			D800F=D804F	1.5
			U3E1\G10000F=U3E1\G10004F	2.0
			U3E1\HG10000F=U3E1\HG10004F	1.8
	+	Addition	#0=#1+#2	2.2
			D800=D801+D802	2.2
			U3E1\G10000=U3E1\G10001+U3E1\G10002	4.6
			U3E1\HG10000=U3E1\HG10001+U3E1\HG10002	2.8
			#0L=#2L+#4L	2.2
			D800L=D802L+D804L	2.2
			U3E1\G10000L=U3E1\G10002L+U3E1\G10004L	3.2
			U3E1\HG10000L=U3E1\HG10002L+U3E1\HG10004L	2.9
			#0F=#4F+#8F	2.2
			D800F=D804F+D808F	2.2
			U3E1\G10000F=U3E1\G10004F+U3E1\G10008F	3.2
			U3E1\HG10000F=U3E1\HG10004F+U3E1\HG10008F	2.9
	-	Subtraction	#0=#1-#2	2.2
			D800=D801-D802	2.2
			U3E1\G10000=U3E1\G10001-U3E1\G10002	3.1
			U3E1\HG10000=U3E1\HG10001-U3E1\HG10002	2.8
			#0L=#2L-#4L	2.2
			D800L=D802L-D804L	2.2
			U3E1\G10000L=U3E1\G10002L-U3E1\G10004L	3.2
			U3E1\HG10000L=U3E1\HG10002L-U3E1\HG10004L	2.9
			#0F=#4F-#8F	2.2
			D800F=D804F-D808F	2.2
			U3E1\G10000F=U3E1\G10004F-U3E1\G10008F	3.2
			U3E1\HG10000F=U3E1\HG10004F-U3E1\HG10008F	2.9

Classifications	Symbol	Instruction	Operation expression	Unit [μ s]
Binary operation	*	Multiplication	#0=#1*#2	2.2
			D800=D801*D802	2.2
			U3E1\G10000=U3E1\G10001*U3E1\G10002	3.1
			U3E1\HG10000=U3E1\HG10001*U3E1\HG10002	2.8
			#0L=#2L*#4L	2.2
			D800L=D802L*D804L	2.2
			U3E1\G10000L=U3E1\G10002L*U3E1\G10004L	3.1
			U3E1\HG10000L=U3E1\HG10002L*U3E1\HG10004L	2.9
			#0F=#4F*#8F	2.2
			D800F=D804F*D808F	2.2
			U3E1\G10000F=U3E1\G10004F*U3E1\G10008F	3.2
			U3E1\HG10000F=U3E1\HG10004F*U3E1\HG10008F	2.9
	/	Division	#0=#1/#2	2.2
			D800=D801/D802	2.2
			U3E1\G10000=U3E1\G10001/U3E1\G10002	3.2
			U3E1\HG10000=U3E1\HG10001/U3E1\HG10002	2.9
			#0L=#2L/#4L	2.2
			D800L=D802L/D804L	2.2
			U3E1\G10000L=U3E1\G10002L/U3E1\G10004L	3.2
			U3E1\HG10000L=U3E1\HG10002L/U3E1\HG10004L	2.9
			#0F=#4F/#8F	3.4
			D800F=D804F/D808F	3.4
			U3E1\G10000F=U3E1\G10004F/U3E1\G10008F	4.8
			U3E1\HG10000F=U3E1\HG10004F/U3E1\HG10008F	4.5
	%	Remainder	#0=#1%#2	2.2
			D800=D801%D802	2.2
			U3E1\G10000=U3E1\G10001%U3E1\G10002	3.2
			U3E1\HG10000=U3E1\HG10001%U3E1\HG10002	2.9
			#0L=#2L%#4L	2.2
			D800L=D802L%D804L	2.2
			U3E1\G10000L=U3E1\G10002L%U3E1\G10004L	3.2
			U3E1\HG10000L=U3E1\HG10002L%U3E1\HG10004L	2.9
	Bit operation	~	Bit inversion (complement)	#0=~#1
D800=~D801				1.6
U3E1\G10000=~U3E1\G10001				2.0
U3E1\HG10000=~U3E1\HG10001				1.9
#0L=~#2L				1.6
D800L=~D802L				1.6
U3E1\G10000L=~U3E1\G10002L				2.1
U3E1\HG10000L=~U3E1\HG10002L				1.9
&		Bit logical AND	#0=#1	2.1
			D800=D801&D802	2.1
			U3E1\G10000=U3E1\G10001&U3E1\G10002	3.1
			U3E1\HG10000=U3E1\HG10001&U3E1\HG10002	2.8
			#0L=#2LL	2.1
			D800L=D802L&D804L	2.2
			U3E1\G10000L=U3E1\G10002L&U3E1\G10004L	3.1
U3E1\HG10000L=U3E1\HG10002L&U3E1\HG10004L	2.8			



Classifications	Symbol	Instruction	Operation expression	Unit [μ s]
Bit operation		Bit logical OR	#0=#1 #2	2.1
			D800=D801 D802	2.1
			U3E1\G10000=U3E1\G10001 U3E1\G10002	3.1
			U3E1\HG10000=U3E1\HG10001 U3E1\HG10002	2.8
			#0L=#2L #4L	2.2
			D800L=D802L D804L	2.2
			U3E1\G10000L=U3E1\G10002L U3E1\G10004L	3.1
			U3E1\HG10000L=U3E1\HG10002L U3E1\HG10004L	2.8
	^	Bit exclusive OR	#0=#1^#2	2.1
			D800=D801^D802	2.1
			U3E1\G10000=U3E1\G10001^U3E1\G10002	3.1
			U3E1\HG10000=U3E1\HG10001^U3E1\HG10002	2.8
			#0L=#2L^#4L	2.2
			D800L=D802L^D804L	2.2
			U3E1\G10000L=U3E1\G10002L^U3E1\G10004L	3.1
			U3E1\HG10000L=U3E1\HG10002L^U3E1\HG10004L	2.8
	>>	Bit right shift	#0=#1>>#2	2.2
			D800=D801>>D802	2.1
			U3E1\G10000=U3E1\G10001>>U3E1\G10002	3.1
			U3E1\HG10000=U3E1\HG10001>>U3E1\HG10002	2.8
			#0L=#2L>>#4L	2.2
			D800L=D802L>>D804L	2.2
			U3E1\G10000L=U3E1\G10002L>>U3E1\G10004L	3.1
			U3E1\HG10000L=U3E1\HG10002L>>U3E1\HG10004L	2.8
	<<	Bit left shift	#0=#1<<#2	2.1
			D800=D801<<D802	2.1
			U3E1\G10000=U3E1\G10001<<U3E1\G10002	3.1
			U3E1\HG10000=U3E1\HG10001<<U3E1\HG10002	2.8
#0L=#2L<<#4L			2.2	
D800L=D802L<<D804L			2.2	
U3E1\G10000L=U3E1\G10002L<<U3E1\G10004L			3.2	
U3E1\HG10000L=U3E1\HG10002L<<U3E1\HG10004L			2.8	
Sign	-	Sign inversion (complement of 2)	#0=-#1	1.6
			D800=-D812	1.6
			U3E1\G10000=-U3E1\G10001	2.1
			U3E1\HG10000=-U3E1\HG10001	1.9
			#0L=-#2L	1.6
			D800L=-D802L	1.6
			U3E1\G10000L=-U3E1\G10002L	2.1
			U3E1\HG10000L=-U3E1\HG10002L	1.9
			#0F=-#4F	2.5
			D800F=-D804F	2.4
			U3E1\G10000F=-U3E1\G10004F	2.9
			U3E1\HG10000F=-U3E1\HG10004F	2.8

Classifications	Symbol	Instruction	Operation expression	Unit [μ s]
Standard function	SIN	Sine	#0F=SIN(#4F)	4.7
			D800F=SIN(D804F)	4.6
			U3E1\G10000F=SIN(U3E1\G10004F)	5.8
			U3E1\HG10000F=SIN(U3E1\HG10004F)	5.6
	COS	Cosine	#0F=COS(#4F)	4.6
			D800F=COS(D804F)	4.6
			U3E1\G10000F=COS(U3E1\G10004F)	5.8
			U3E1\HG10000F=COS(U3E1\HG10004F)	5.6
	TAN	Tangent	#0F=TAN(#4F)	4.7
			D800F=TAN(D804F)	4.7
			U3E1\G10000F=TAN(U3E1\G10004F)	6.0
			U3E1\HG10000F=TAN(U3E1\HG10004F)	5.8
	ASIN	Arcsine	#0F=ASIN(#4F)	7.6
			D800F=ASIN(D804F)	7.5
			U3E1\G10000F=ASIN(U3E1\G10004F)	8.4
			U3E1\HG10000F=ASIN(U3E1\HG10004F)	8.2
ACOS	Arccosine	#0F=ACOS(#4F)	5.3	
		D800F=ACOS(D804F)	5.3	
		U3E1\G10000F=ACOS(U3E1\G10004F)	6.1	
		U3E1\HG10000F=ACOS(U3E1\HG10004F)	6.1	
ATAN	Arctangent	#0F=ATAN(#4F)	6.0	
		D800F=ATAN(D804F)	6.0	
		U3E1\G10000F=ATAN(U3E1\G10004F)	6.8	
		U3E1\HG10000F=ATAN(U3E1\HG10004F)	6.8	
SQRT	Square root	#0F=SQRT(#4F)	3.9	
		D800F=SQRT(D804F)	3.9	
		U3E1\G10000F=SQRT(U3E1\G10004F)	4.8	
		U3E1\HG10000F=SQRT(U3E1\HG10004F)	4.7	
LN	Natural logarithm	#0F=LN(#4F)	4.1	
		D800F=LN(D804F)	4.1	
		U3E1\G10000F=LN(U3E1\G10004F)	5.4	
		U3E1\HG10000F=LN(U3E1\HG10004F)	5.2	
EXP	Exponential operation	#0F=EXP(#4F)	14.2	
		D800F=EXP(D804F)	14.2	
		U3E1\G10000F=EXP(U3E1\G10004F)	15.6	
		U3E1\HG10000F=EXP(U3E1\HG10004F)	15.4	
ABS	Absolute value	#0F=ABS(#4F)	1.6	
		D800F=ABS(D804F)	1.6	
		U3E1\G10000F=ABS(U3E1\G10004F)	2.1	
		U3E1\HG10000F=ABS(U3E1\HG10004F)	1.9	
RND	Round-off	#0F=RND(#4F)	3.5	
		D800F=RND(D804F)	3.5	
		U3E1\G10000F=RND(U3E1\G10004F)	4.0	
		U3E1\HG10000F=RND(U3E1\HG10004F)	3.8	
FIX	Round-down	#0F=FIX(#4F)	2.5	
		D800F=FIX(D804F)	2.5	
		U3E1\G10000F=FIX(U3E1\G10004F)	3.0	
		U3E1\HG10000F=FIX(U3E1\HG10004F)	2.8	
FUP	Round-up	#0F=FUP(#4F)	2.5	
		D800F=FUP(D804F)	2.5	
		U3E1\G10000F=FUP(U3E1\G10004F)	3.0	
		U3E1\HG10000F=FUP(U3E1\HG10004F)	2.8	

Classifications	Symbol	Instruction	Operation expression	Unit [μ s]
Standard function	BIN	BCD \rightarrow BIN conversion	#0=BIN(#1)	1.6
			D800=BIN(D801)	1.6
			U3E1\G10000=BIN(U3E1\G10001)	2.1
			U3E1\HG10000=BIN(U3E1\HG10001)	1.9
			#0L=BIN(#2L)	1.7
			D800L=BIN(D802L)	1.7
			U3E1\G10000L=BIN(U3E1\G10002L)	2.2
			U3E1\HG10000L=BIN(U3E1\HG10002L)	2.0
	BCD	BIN \rightarrow BCD conversion	#0=BCD(#1)	1.7
			D800=BCD(D801)	1.7
			U3E1\G10000=BCD(U3E1\G10001)	2.2
			U3E1\HG10000=BCD(U3E1\HG10001)	2.0
			#0L=BCD(#2L)	1.8
			D800L=BCD(D802L)	1.8
			U3E1\G10000L=BCD(U3E1\G10002L)	2.3
			U3E1\HG10000L=BCD(U3E1\HG10002L)	2.1
Data control	SCL	16-bit integer type scaling	SCL K0,K2000,#0,#2002 ^{*1}	6.9
			SCL K0,K2000,D2000,D4002 ^{*1}	6.9
			SCL K0,K2000,U3E1\G10000,U3E1\G12002 ^{*1}	17.4
			SCL K0,K2000,U3E1\HG0,U3E1\HG12002 ^{*1}	14.8
			SCL K0,K2000,#0,#2002 ^{*2}	43.1
			SCL K0,K2000,D2000,D4002 ^{*2}	43.1
			SCL K0,K2000,U3E1\G10000,U3E1\G12002 ^{*2}	133.6
			SCL K0,K2000,U3E1\HG0,U3E1\HG12002 ^{*2}	110.9
			SCL K0,K2000,#0,#2002 ^{*3}	405.4
			SCL K0,K2000,D2000,D4002 ^{*3}	405.3
			SCL K0,K2000,U3E1\G10000,U3E1\G12002 ^{*3}	1298.1
			SCL K0,K2000,U3E1\HG0,U3E1\HG12002 ^{*3}	1093.9
			SCL K2,K1,#0,#2002 ^{*1}	4.5
			SCL K2,K1,D2000,D4002 ^{*1}	4.6
			SCL K2,K1,U3E1\G10000,U3E1\G12002 ^{*1}	9.6
			SCL K2,K1,U3E1\HG0,U3E1\HG12002 ^{*1}	8.3
	DSCL	32-bit integer type scaling	DSCL K0,K2000L,#0,#4002L ^{*1}	6.9
			DSCL K0,K2000L,D2000,D6002L ^{*1}	6.9
			DSCL K0,K2000L,U3E1\G10000,U3E1\G14002L ^{*1}	17.4
			DSCL K0,K2000L,U3E1\HG0,U3E1\HG12002L ^{*1}	14.6
			DSCL K0,K2000L,#0,#4002L ^{*2}	42.8
			DSCL K0,K2000L,D2000,D6002L ^{*2}	43.5
			DSCL K0,K2000L,U3E1\G10000,U3E1\G14002L ^{*2}	135.9
			DSCL K0,K2000L,U3E1\HG0,U3E1\HG12002L ^{*2}	111.0
			DSCL K0,K2000L,#0,#4002L ^{*3}	415.4
			DSCL K0,K2000L,D2000,D6002L ^{*3}	415.3
			DSCL K0,K2000L,U3E1\G10000,U3E1\G14002L ^{*3}	1306.0
			DSCL K0,K2000L,U3E1\HG0,U3E1\HG12002L ^{*3}	1074.1
			DSCL K2,K1L,#0,#4002L ^{*1}	4.6
			DSCL K2,K1L,D2000,D6002L ^{*1}	4.6
			DSCL K2,K1L,U3E1\G10000,U3E1\G14002L ^{*1}	9.8
			DSCL K2,K1L,U3E1\HG0,U3E1\HG12002L ^{*1}	8.3

Classifications	Symbol	Instruction	Operation expression	Unit [μs]
Type conversion	SHORT	Converted into 16-bit integer type (signed)	#0=SHORT(#2L)	1.6
			D800=SHORT(D802L)	1.6
			U3E1\G10000=SHORT(U3E1\G10002L)	2.1
			U3E1\HG10000=SHORT(U3E1\HG10002L)	1.9
			#0=SHORT(#4F)	1.7
			D800=SHORT(D804F)	1.7
			U3E1\G10000=SHORT(U3E1\G10004F)	2.2
			U3E1\HG10000=SHORT(U3E1\HG10004F)	2.0
	USHORT	Converted into 16-bit integer type (unsigned)	#0=USHORT(#2L)	1.6
			D800=USHORT(D802L)	1.6
			U3E1\G10000=USHORT(U3E1\G10002L)	2.1
			U3E1\HG10000=USHORT(U3E1\HG10002L)	1.9
			#0=USHORT(#4F)	1.7
			D800=USHORT(D804F)	1.7
			U3E1\G10000=USHORT(U3E1\G10004F)	2.2
			U3E1\HG10000=USHORT(U3E1\HG10004F)	2.0
	LONG	Converted into 32-bit integer type (signed)	#0L=LONG(#2)	1.6
			D800L=LONG(D802)	1.6
			U3E1\G10000L=LONG(U3E1\G10002)	2.1
			U3E1\HG10000L=LONG(U3E1\HG10002)	1.9
			#0L=LONG(#4F)	1.7
			D800L=LONG(D804F)	1.7
			U3E1\G10000L=LONG(U3E1\G10004F)	2.2
			U3E1\HG10000L=LONG(U3E1\HG10004F)	2.0
	ULONG	Converted into 32-bit integer type (unsigned)	#0L=ULONG(#2)	1.6
			D800L=ULONG(D802)	1.6
			U3E1\G10000L=ULONG(U3E1\G10002)	2.1
			U3E1\HG10000L=ULONG(U3E1\HG10002)	1.9
#0L=ULONG(#4F)			1.7	
D800L=ULONG(D804F)			1.7	
U3E1\G10000L=ULONG(U3E1\G10004F)			2.2	
U3E1\HG10000L=ULONG(U3E1\HG10004F)			2.0	
FLOAT	Converted into 64-bit floating point type (signed)	#0F=FLOAT(#4)	1.6	
		D800F=FLOAT(D804)	1.6	
		U3E1\G10000F=FLOAT(U3E1\G10004)	2.1	
		U3E1\HG10000F=FLOAT(U3E1\HG10004)	1.9	
		#0F=FLOAT(#4L)	1.6	
		D800F=FLOAT(D804L)	1.6	
		U3E1\G10000F=FLOAT(U3E1\G10004L)	2.1	
		U3E1\HG10000F=FLOAT(U3E1\HG10004L)	1.9	
UFLOAT	Converted into 64-bit floating point type (unsigned)	#0F=UFLOAT(#4)	1.6	
		D800F=UFLOAT(D804)	1.6	
		U3E1\G10000F=UFLOAT(U3E1\G10004)	2.1	
		U3E1\HG10000F=UFLOAT(U3E1\HG10004)	1.9	
		#0F=UFLOAT(#4L)	1.6	
		D800F=UFLOAT(D804L)	1.6	
		U3E1\G10000F=UFLOAT(U3E1\G10004L)	2.1	
		U3E1\HG10000F=UFLOAT(U3E1\HG10004L)	1.9	
DFLT	Floating-point value conversion 32-bit into 64-bit	#0F=DFLT(#4L)	1.6	
		D2000F=DFLT(D2004L)	1.6	
		U3E1\G10000F=DFLT(U3E1\G10004L)	2.1	
		U3E1\HG10000F=DFLT(U3E1\HG10004L)	2.0	

A

Classifications	Symbol	Instruction	Operation expression	Unit [μ s]
Type conversion	SFLT	Floating-point value conversion 64-bit into 32-bit	#0L=SFLT(#2F)	1.7
			D2000L=SFLT(D2002F)	1.7
			U3E1\G10000L=SFLT(U3E1\G10002F)	2.6
			U3E1\HG10000L=SFLT(U3E1\HG10002F)	2.4
Bit device status	(None)	ON (normally open contact) (Completion of condition)	SET M1000=M0	1.4
			SET M1000=X100	1.5
			SET M1000=X20 ^{*4}	4.6
			SET M1000=U3E1\G10000.0	2.0
			SET M1000=U3E1\HG10000.0	1.8
	!	OFF (normally closed contact) (Completion of condition)	SET M1000=!M0	1.5
			SET M1000=!X100	1.6
			SET M1000=!X20 ^{*4}	4.7
			SET M1000=!U3E1\G10000.0	2.0
			SET M1000=!U3E1\HG10000.0	1.9
Bit device control	SET	Device set	SET M1000	0.9
			SET Y100	0.9
			SET Y60 ^{*4}	3.2
			SET U3E1\G11000.0	1.5
			SET U3E1\HG11000.0	1.4
	RST	Device reset	RST M1000	0.9
			RST Y100	0.9
			RST Y60 ^{*4}	3.2
			RST U3E1\G11000.0	1.5
			RST U3E1\HG11000.0	1.4
	DOUT	Device output	DOUT M0,#0	1.5
			DOUT Y100,#0	1.5
			DOUT Y60,#0 ^{*4}	4.0
			DOUT M0,#0L	1.5
			DOUT Y100,#0L	1.5
			DOUT Y60,#0L ^{*4}	4.1
	DIN	Device input	DIN #0,M0	1.5
			DIN #0,X0	1.5
			DIN #0,X20 ^{*4}	6.2
			DIN #0L,M0	1.5
			DIN #0L,X0	1.6
			DIN #0L,X20 ^{*4}	6.5
	OUT	Bit device output	OUT M100=M0	1.4
			OUT Y0=M0	1.5
OUT Y60=M0 ^{*4}			3.8	
OUT U3E1\G10000.0=M0			2.1	
OUT U3E1\HG10000.0=M0			1.9	
Logical operation	*	Logical AND	SET M1000=M0*M1	2.0
			SET M1000=X100*X101	1.7
			SET M1000=X20*X21 ^{*4}	9.5
			SET M1000=U3E1\G10000.0*U3E1\G10000.1	2.6
			SET M1000=U3E1\HG10000.0*U3E1\HG10000.1	2.3
	+	Logical OR	SET M1000=M0+M1	2.0
			SET M1000=X100+X101	1.7
			SET M1000=X20+X21 ^{*4}	9.4
			SET M1000=U3E1\G10000.0+U3E1\G10000.1	3.1
			SET M1000=U3E1\HG10000.0+U3E1\HG10000.1	2.9

Classifications	Symbol	Instruction	Operation expression	Unit [μs]
Comparison operation	==	Equal to (Completion of condition)	SET M1000=#0==#1	2.1
			SET M1000=D800==D801	2.1
			SET M1000=U3E1\G10000==U3E1\G10001	3.1
			SET M1000=U3E1\HG10000==U3E1\HG10001	2.8
			SET M1000=#0L==#2L	2.2
			SET M1000=D800L==D802L	2.2
			SET M1000=U3E1\G10000L==U3E1\G10002L	3.2
			SET M1000=U3E1\HG10000L==U3E1\HG10002L	2.9
			SET M1000=#0F==#4F	2.2
			SET M1000=D800F==D804F	2.2
			SET M1000=U3E1\G10000F==U3E1\G10004F	3.2
			SET M1000=U3E1\HG10000F==U3E1\HG10004F	2.9
	!=	Not equal to (Completion of condition)	SET M1000=#0!=#1	2.1
			SET M1000=D800!=D801	2.1
			SET M1000=U3E1\G10000!=U3E1\G10001	3.1
			SET M1000=U3E1\HG10000!=U3E1\HG10001	2.9
			SET M1000=#0L!=#2L	2.1
			SET M1000=D800L!=D802L	2.2
			SET M1000=U3E1\G10000L!=U3E1\G10002L	3.1
			SET M1000=U3E1\HG10000L!=U3E1\HG10002L	2.9
			SET M1000=#0F!=#4F	2.2
			SET M1000=D800F!=D804F	2.2
			SET M1000=U3E1\G10000F!=U3E1\G10004F	3.2
			SET M1000=U3E1\HG10000F!=U3E1\HG10004F	2.9
	<	Less than (Completion of condition)	SET M1000=#0<#1	2.1
			SET M1000=D800<D801	2.1
			SET M1000=U3E1\G10000<U3E1\G10001	3.1
			SET M1000=U3E1\HG10000<U3E1\HG10001	2.8
			SET M1000=#0L<#2L	2.2
			SET M1000=D800L<D802L	2.2
			SET M1000=U3E1\G10000L<U3E1\G10002L	3.1
			SET M1000=U3E1\HG10000L<U3E1\HG10002L	2.9
			SET M1000=#0F<#4F	2.2
			SET M1000=D800F<D804F	2.2
			SET M1000=U3E1\G10000F<U3E1\G10004F	3.2
			SET M1000=U3E1\HG10000F<U3E1\HG10004F	2.9
<=	Less than or equal to (Completion of condition)	SET M1000=#0<=#1	2.1	
		SET M1000=D800<=#D801	2.2	
		SET M1000=U3E1\G10000<=#U3E1\G10001	3.1	
		SET M1000=U3E1\HG10000<=#U3E1\HG10001	2.9	
		SET M1000=#0L<=#2L	2.2	
		SET M1000=D800L<=#D802L	2.2	
		SET M1000=U3E1\G10000L<=#U3E1\G10002L	3.2	
		SET M1000=U3E1\HG10000L<=#U3E1\HG10002L	2.9	
		SET M1000=#0F<=#4F	2.2	
		SET M1000=D800F<=#D804F	2.2	
		SET M1000=U3E1\G10000F<=#U3E1\G10004F	3.2	
		SET M1000=U3E1\HG10000F<=#U3E1\HG10004F	2.9	



Classifications	Symbol	Instruction	Operation expression	Unit [μ s]
Comparison operation	>	More than (Completion of condition)	SET M1000=#0>#1	2.1
			SET M1000=D800>D801	2.1
			SET M1000=U3E1\G10000>U3E1\G10001	3.1
			SET M1000=U3E1\HG10000>U3E1\HG10001	2.9
			SET M1000=#0L>#2L	2.1
			SET M1000=D800L>D802L	2.1
			SET M1000=U3E1\G10000L>U3E1\G10002L	3.1
			SET M1000=U3E1\HG10000L>U3E1\HG10002L	2.9
			SET M1000=#0F>#4F	2.2
			SET M1000=D800F>D804F	2.2
			SET M1000=U3E1\G10000F>U3E1\G10004F	3.2
			SET M1000=U3E1\HG10000F>U3E1\HG10004F	2.9
	>=	More than or equal to (Completion of condition)	SET M1000=#0>=#1	2.1
			SET M1000=D800>=D801	2.1
			SET M1000=U3E1\G10000>=U3E1\G10001	3.1
			SET M1000=U3E1\HG10000>=U3E1\HG10001	2.8
			SET M1000=#0L>=#2L	2.1
			SET M1000=D800L>=D802L	2.1
			SET M1000=U3E1\G10000L>=U3E1\G10002L	3.2
			SET M1000=U3E1\HG10000L>=U3E1\HG10002L	2.9
			SET M1000=#0F>=#4F	2.2
			SET M1000=D800F>=D804F	2.2
			SET M1000=U3E1\G10000F>=U3E1\G10004F	3.2
			SET M1000=U3E1\HG10000F>=U3E1\HG10004F	2.9

Classifications	Symbol	Instruction	Operation expression	Unit [μs]
Program control	IF-ELSE-IEND	Conditional branch control	IF #0==#1 ⁵ #2=#3 ELSE #4=#5 IEND	3.3
			IF D800==D801 ⁵ #2=#3 ELSE #4=#5 IEND	1.6
			IF U3E1\G10000==U3E1\G10001 ⁵ #2=#3 ELSE #4=#5 IEND	2.1
			IF U3E1\HG10000==U3E1\HG10001 ⁵ #2=#3 ELSE #4=#5 IEND	2.0
			IF #0==#1 ⁶ #2=#3 ELSE #4=#5 IEND	1.6
			IF D800==D801 ⁶ #2=#3 ELSE #4=#5 IEND	1.6
			IF U3E1\G10000==U3E1\G10001 ⁶ #2=#3 ELSE #4=#5 IEND	2.1
			IF U3E1\HG10000==U3E1\HG10001 ⁶ #2=#3 ELSE #4=#5 IEND	2.0

A

Classifications	Symbol	Instruction	Operation expression	Unit [μs]
Program control	SELECT- CASE- SEND	Selective branch control	SELECT ⁷ CASE #0==K1 #2=#3 CEND CASE #1==K1 #4=#5 CEND CELSE #6=#7 CEND SEND	3.1
			SELECT ⁷ CASE D800==K1 #2=#3 CEND CASE D801==K1 #4=#5 CEND CELSE #6=#7 CEND SEND	0.8
			SELECT ⁷ CASE U3E1\G10000==K1 #2=#3 CEND CASE U3E1\G10001==K1 #4=#5 CEND CELSE #6=#7 CEND SEND	0.9
			SELECT ⁷ CASE U3E1\HG10000==K1 #2=#3 CEND CASE U3E1\HG10001==K1 #4=#5 CEND CELSE #6=#7 CEND SEND	0.9
			SELECT ⁸ CASE #0==K1 #2=#3 CEND CASE #1==K1 #4=#5 CEND CELSE #6=#7 CEND SEND	1.0
			SELECT ⁸ CASE D800==K1 #2=#3 CEND CASE D801==K1 #4=#5 CEND CELSE #6=#7 CEND SEND	1.0
			SELECT ⁸ CASE D800==K1 #2=#3 CEND CASE D801==K1 #4=#5 CEND CELSE #6=#7 CEND SEND	1.0

Classifications	Symbol	Instruction	Operation expression	Unit [μs]
Program control	SELECT- CASE- SEND	Selective branch control	SELECT ⁸ CASE U3E1\G10000==K1 #2=#3 CEND CASE U3E1\G10001==K1 #4=#5 CEND CELSE #6=#7 CEND SEND	1.3
			SELECT ⁸ CASE U3E1\HG10000==K1 #2=#3 CEND CASE U3E1\HG10001==K1 #4=#5 CEND CELSE #6=#7 CEND SEND	1.2
			SELECT ⁹ CASE #0==K1 #2=#3 CEND CASE #1==K1 #4=#5 CEND CELSE #6=#7 CEND SEND	1.1
			SELECT ⁹ CASE D800==K1 #2=#3 CEND CASE D801==K1 #4=#5 CEND CELSE #6=#7 CEND SEND	1.1
			SELECT ⁹ CASE U3E1\G10000==K1 #2=#3 CEND CASE U3E1\G10001==K1 #4=#5 CEND CELSE #6=#7 CEND SEND	1.4
			SELECT ⁹ CASE U3E1\HG10000==K1 #2=#3 CEND CASE U3E1\HG10001==K1 #4=#5 CEND CELSE #6=#7 CEND SEND	1.3



Classifications	Symbol	Instruction	Operation expression	Unit [μ s]
Program control	FOR-NEXT	Repeat control with specified count	FOR #0=K1 TO 10 #1=#1+1 NEXT	47.6
			FOR D800=K1 TO 10 #1=#1+1 NEXT	23.8
			FOR U3E1\G10000=K1 TO 10 #1=#1+1 NEXT	29.1
			FOR U3E1\HG10000=K1 TO 10 #1=#1+1 NEXT	27.6
Motion dedicated function	CHGV	Speed change request	CHGV(K1,#0)	1.3
			CHGV(K1,D800)	1.3
			CHGV(K1,U3E1\G10000)	1.8
			CHGV(K1,U3E1\HG10000)	1.7
			CHGV(K1,#0L)	1.3
			CHGV(K1,D800L)	1.3
			CHGV(K1,U3E1\G10000L)	1.8
			CHGV(K1,U3E1\HG10000L)	1.7
	CHGVS	Command generation axis speed change request	CHGVS(K1,#0)	1.3
			CHGVS(K1,D800)	1.3
			CHGVS(K1,U3E1\G10000)	1.8
			CHGVS(K1,U3E1\HG10000)	1.7
			CHGVS(K1,#0L)	1.3
			CHGVS(K1,D800L)	1.3
			CHGVS(K1,U3E1\G10000L)	1.8
			CHGVS(K1,U3E1\HG10000L)	1.7
	CHGT	Torque limit value change request	CHGT(K1,#0,#1)	1.6
			CHGT(K1,D800,D801)	1.6
			CHGT(K1,U3E1\G10000,U3E1\G10001)	2.6
			CHGT(K1,U3E1\HG10000,U3E1\HG10001)	2.3
			CHGT(K1,#0L,#2L)	1.7
			CHGT(K1,D800L,D802L)	1.7
			CHGT(K1,U3E1\G10000L,U3E1\G10002L)	2.7
			CHGT(K1,U3E1\HG10000L,U3E1\HG10002L)	2.4
	CHGP	Target position change request	CHGP(K1,K1,#0) ^{*10}	3.0
			CHGP(K1,K1,D800) ^{*10}	3.0
			CHGP(K1,K1,U3E1\G10000) ^{*10}	4.2
			CHGP(K1,K1,U3E1\HG10000) ^{*10}	3.8
CHGP(K1,K1,#0) ^{*11}			2.0	
CHGP(K1,K1,D800) ^{*11}			1.9	
CHGP(K1,K1,U3E1\G10000) ^{*11}			4.2	
CHGP(K1,K1,U3E1\HG10000) ^{*11}			3.8	

Classifications	Symbol	Instruction	Operation expression	Unit [μs]
Motion dedicated function	MCNST	Machine program operation start request	MCNST(#13000,#12998) ^{*12}	153.2
			MCNST(D58000,D57998) ^{*12}	144.0
			MCNST(U3E1\G10002,U3E1\G10000) ^{*12}	165.2
			MCNST(U3E1\HG5002,U3E1\HG5000) ^{*12}	160.6
			MCNST(#13000,#12998) ^{*13}	1187.7
			MCNST(D58000,D57998) ^{*13}	1195.1
			MCNST(U3E1\G10002,U3E1\G10000) ^{*13}	2221.8
			MCNST(U3E1\HG5002,U3E1\HG5000) ^{*13}	2050.2
			MCNST(#13000,#12998) ^{*14}	1485.0
			MCNST(D58000,D57998) ^{*14}	1487.7
			MCNST(U3E1\G10002,U3E1\G10000) ^{*14}	3470.5
			MCNST(U3E1\HG5002,U3E1\HG5000) ^{*14}	3194.7
			Advanced synchronous control dedicated function	CAMRD
CAMRD D2000,D2002L,K256,D2004 ^{*15}	46.1			
CAMRD U3E1\G10000,U3E1\G10002L,K256,U3E1\G10004 ^{*15}	19.5			
CAMRD U3E1\HG10000,U3E1\HG10002L,K256,U3E1\HG0 ^{*15}	19.2			
CAMRD #0,#2L,K1024,#4 ^{*15}	190.5			
CAMRD D2000,D2002L,K1024,D2004 ^{*15}	191.0			
CAMRD U3E1\G10000,U3E1\G10002L,K1024,U3E1\G10004 ^{*15}	58.6			
CAMRD U3E1\HG10000,U3E1\HG10002L,K1024,U3E1\HG0 ^{*15}	58.2			
CAMRD #0,#2L,K2048,#4 ^{*15}	382.5			
CAMRD D2000,D2002L,K2048,D2004 ^{*15}	383.1			
CAMRD U3E1\G10000,U3E1\G10002L,K2048,U3E1\G10004 ^{*15}	113.0			
CAMRD U3E1\HG10000,U3E1\HG10002L,K2048,U3E1\HG0 ^{*15}	112.9			
CAMRD #0,#2L,K256,#4 ^{*16}	95.0			
CAMRD D2000,D2002L,K256,D2004 ^{*16}	94.2			
CAMRD U3E1\G10000,U3E1\G10002L,K256,U3E1\G10004 ^{*16}	31.2			
CAMRD U3E1\HG10000,U3E1\HG10002L,K256,U3E1\HG0 ^{*16}	31.0			
CAMRD #0,#2L,K512,#4 ^{*16}	190.6			
CAMRD D2000,D2002L,K512,D2004 ^{*16}	191.0			
CAMRD U3E1\G10000,U3E1\G10002L,K512,U3E1\G10004 ^{*16}	58.6			
CAMRD U3E1\HG10000,U3E1\HG10002L,K512,U3E1\HG0 ^{*16}	58.3			
CAMRD #0,#2L,K1024,#4 ^{*16}	382.4			
CAMRD D2000,D2002L,K1024,D2004 ^{*16}	383.1			
CAMRD U3E1\G10000,U3E1\G10002L,K1024,U3E1\G10004 ^{*16}	113.3			
CAMRD U3E1\HG10000,U3E1\HG10002L,K1024,U3E1\HG0 ^{*16}	113.0			



Classifications	Symbol	Instruction	Operation expression	Unit [μs]		
Advanced synchronous control dedicated function	CAMWR	Cam data write	CAMWR #0,#2L,K256,#4,H401 ^{*15}	27.3		
			CAMWR D2000,D2002L,K256,D2004,H401 ^{*15}	27.1		
			CAMWR U3E1\G10000,U3E1\G10002L,K256,U3E1\G10004,H401 ^{*15}	107.2		
			CAMWR U3E1\HG10000,U3E1\HG10002L,K256,U3E1\HG0,H401 ^{*15}	93.1		
			CAMWR #0,#2L,K1024,#4,H401 ^{*15}	74.5		
			CAMWR D2000,D2002L,K1024,D2004,H401 ^{*15}	72.0		
			CAMWR U3E1\G10000,U3E1\G10002L,K1024,U3E1\G10004,H401 ^{*15}	362.1		
			CAMWR U3E1\HG10000,U3E1\HG10002L,K1024,U3E1\HG0,H401 ^{*15}	308.5		
			CAMWR #0,#2L,K2048,#4,H401 ^{*15}	137.6		
			CAMWR D2000,D2002L,K2048,D2004,H401 ^{*15}	135.8		
			CAMWR U3E1\G10000,U3E1\G10002L,K2048,U3E1\G10004,H401 ^{*15}	702.1		
			CAMWR U3E1\HG10000,U3E1\HG10002L,K2048,U3E1\HG0,H401 ^{*15}	596.6		
			CAMWR #0,#2L,K256,#4,H401 ^{*16}	45.1		
			CAMWR D2000,D2002L,K256,D2004,H401 ^{*16}	46.0		
			CAMWR U3E1\G10000,U3E1\G10002L,K256,U3E1\G10004,H401 ^{*16}	196.9		
			CAMWR U3E1\HG10000,U3E1\HG10002L,K256,U3E1\HG0,H401 ^{*16}	169.7		
			CAMWR #0,#2L,K512,#4,H401 ^{*16}	81.8		
			CAMWR D2000,D2002L,K512,D2004,H401 ^{*16}	81.0		
			CAMWR U3E1\G10000,U3E1\G10002L,K512,U3E1\G10004,H401 ^{*16}	370.6		
			CAMWR U3E1\HG10000,U3E1\HG10002L,K512,U3E1\HG0,H401 ^{*16}	317.5		
			CAMWR #0,#2L,K1024,#4,H401 ^{*16}	153.4		
			CAMWR D2000,D2002L,K1024,D2004,H401 ^{*16}	152.6		
			CAMWR U3E1\G10000,U3E1\G10002L,K1024,U3E1\G10004,H401 ^{*16}	719.9		
			CAMWR U3E1\HG10000,U3E1\HG10002L,K1024,U3E1\HG0,H401 ^{*16}	614.3		
			CAMWR	Cam data write (Cam open area)	CAMWR #0,#2L,K256,#4,H0 ^{*15}	23.5
					CAMWR D2000,D2002L,K256,D2004,H0 ^{*15}	20.4
					CAMWR U3E1\G10000,U3E1\G10002L,K256,U3E1\G10004,H0 ^{*15}	100.6
					CAMWR U3E1\HG10000,U3E1\HG10002L,K256,U3E1\HG0,H0 ^{*15}	86.3
					CAMWR #0,#2L,K1024,#4,H0 ^{*15}	67.4
					CAMWR D2000,D2002L,K1024,D2004,H0 ^{*15}	63.1
					CAMWR U3E1\G10000,U3E1\G10002L,K1024,U3E1\G10004,H0 ^{*15}	348.7
					CAMWR U3E1\HG10000,U3E1\HG10002L,K1024,U3E1\HG0,H0 ^{*15}	294.9
					CAMWR #0,#2L,K2048,#4,H0 ^{*15}	128.1
					CAMWR D2000,D2002L,K2048,D2004,H0 ^{*15}	123.5
CAMWR U3E1\G10000,U3E1\G10002L,K2048,U3E1\G10004,H0 ^{*15}	684.8					
CAMWR U3E1\HG10000,U3E1\HG10002L,K2048,U3E1\HG0,H0 ^{*15}	578.6					
CAMWR #0,#2L,K256,#4,H0 ^{*16}	39.2					
CAMWR D2000,D2002L,K256,D2004,H0 ^{*16}	38.4					
CAMWR U3E1\G10000,U3E1\G10002L,K256,U3E1\G10004,H0 ^{*16}	184.9					
CAMWR U3E1\HG10000,U3E1\HG10002L,K256,U3E1\HG0,H0 ^{*16}	157.4					
CAMWR #0,#2L,K512,#4,H0 ^{*16}	72.6					
CAMWR D2000,D2002L,K512,D2004,H0 ^{*16}	71.3					
CAMWR U3E1\G10000,U3E1\G10002L,K512,U3E1\G10004,H0 ^{*16}	356.1					
CAMWR U3E1\HG10000,U3E1\HG10002L,K512,U3E1\HG0,H0 ^{*16}	302.7					
CAMWR #0,#2L,K1024,#4,H0 ^{*16}	139.9					
CAMWR D2000, D2002L, K1024, D2004,H0 ^{*16}	138.7					
CAMWR U3E1\G10000,U3E1\G10002L,K1024,U3E1\G10004,H0 ^{*16}	700.1					
CAMWR U3E1\HG10000,U3E1\HG10002L,K1024,U3E1\HG0,H0 ^{*16}	594.0					

Classifications	Symbol	Instruction	Operation expression	Unit [μs]
Advanced synchronous control dedicated function	CAMMK	Cam auto-generation	CAMMK #0,#1,#2 ^{*17}	275.6
			CAMMK D2000,D2001,D2002 ^{*17}	258.3
			CAMMK U3E1\G10000,U3E1\G10001,U3E1\G10002 ^{*17}	263.0
			CAMMK U3E1\HG10000,U3E1\HG10001,U3E1\HG10002 ^{*17}	262.0
			CAMMK #0,#1,#2 ^{*18}	7981.1
			CAMMK D2000,D2001,D2002 ^{*18}	7938.2
			CAMMK U3E1\G10000,U3E1\G10001,U3E1\G10002 ^{*18}	7928.1
			CAMMK U3E1\HG10000,U3E1\HG10001,U3E1\HG10002 ^{*18}	7927.5
			CAMMK #0,#1,#2 ^{*19}	31856.3
			CAMMK D2000,D2001,D2002 ^{*19}	31717.5
			CAMMK U3E1\G10000,U3E1\G10001,U3E1\G10002 ^{*19}	31664.8
			CAMMK U3E1\HG10000,U3E1\HG10001,U3E1\HG10002 ^{*19}	31667.4
			CAMMK #0,#1,#2 ^{*20}	1249.2
			CAMMK D2000,D2001,D2002 ^{*20}	1130.7
			CAMMK U3E1\G10000,U3E1\G10001,U3E1\G10002 ^{*20}	1144.3
			CAMMK U3E1\HG10000,U3E1\HG10001,U3E1\HG10002 ^{*20}	1141.0
			CAMMK #0,#1,#2 ^{*21}	29793.0
			CAMMK D2000,D2001,D2002 ^{*21}	29754.1
			CAMMK U3E1\G10000,U3E1\G10001,U3E1\G10002 ^{*21}	29777.7
			CAMMK U3E1\HG10000,U3E1\HG10001,U3E1\HG10002 ^{*21}	29770.4
			CAMMK #0,#1,#2 ^{*22}	118553.4
			CAMMK D2000,D2001,D2002 ^{*22}	118480.0
			CAMMK U3E1\G10000,U3E1\G10001,U3E1\G10002 ^{*22}	118557.6
			CAMMK U3E1\HG10000,U3E1\HG10001,U3E1\HG10002 ^{*22}	118515.2
			CAMMK #0,#1,#2 ^{*23}	1804.5
			CAMMK D2000,D2001,D2002 ^{*23}	1772.6
			CAMMK U3E1\G10000,U3E1\G10001,U3E1\G10002 ^{*23}	1811.0
			CAMMK U3E1\HG10000,U3E1\HG10001,U3E1\HG10002 ^{*23}	1801.2
			CAMMK #0,#1,#2 ^{*24}	41531.6
			CAMMK D2000,D2001,D2002 ^{*24}	41506.9
CAMMK U3E1\G10000,U3E1\G10001,U3E1\G10002 ^{*24}	41549.0			
CAMMK U3E1\HG10000,U3E1\HG10001,U3E1\HG10002 ^{*24}	41540.1			
CAMMK #0,#1,#2 ^{*25}	164697.7			
CAMMK D2000,D2001,D2002 ^{*25}	164645.2			
CAMMK U3E1\G10000,U3E1\G10001,U3E1\G10002 ^{*25}	164697.9			
CAMMK U3E1\HG10000,U3E1\HG10001,U3E1\HG10002 ^{*25}	164674.1			



Classifications	Symbol	Instruction	Operation expression	Unit [μs]
Advanced synchronous control dedicated function	CAMPSCL	Cam position calculation	CAMPSCL #0,#2,#14L *26*28	8.6
			CAMPSCL D2000,D2002,D2014L *26*28	5.6
			CAMPSCL U3E1\G10000,U3E1\G10002,U3E1\G10014L *26*28	10.6
			CAMPSCL U3E1\HG10000,U3E1\HG10002,U3E1\HG10014L *26*28	10.0
			CAMPSCL #0,#2,#14L *26*29	5.8
			CAMPSCL D2000,D2002,D2014L *26*29	5.5
			CAMPSCL U3E1\G10000,U3E1\G10002,U3E1\G10014L *26*29	9.5
			CAMPSCL U3E1\HG10000,U3E1\HG10002,U3E1\HG10014L *26*29	8.7
			CAMPSCL #0,#2,#14L *26*30	7.1
			CAMPSCL D2000,D2002,D2014L *26*30	5.7
			CAMPSCL U3E1\G10000,U3E1\G10002,U3E1\G10014L *26*30	9.8
			CAMPSCL U3E1\HG10000,U3E1\HG10002,U3E1\HG10014L *26*30	8.9
			CAMPSCL #0,#2,#14L *26*31	7.9
			CAMPSCL D2000,D2002,D2014L *26*31	6.2
			CAMPSCL U3E1\G10000,U3E1\G10002,U3E1\G10014L *26*31	10.1
			CAMPSCL U3E1\HG10000,U3E1\HG10002,U3E1\HG10014L *26*31	9.3
			CAMPSCL #0,#2,#14L *27*28	31.6
			CAMPSCL D2000,D2002,D2014L *27*28	29.0
			CAMPSCL U3E1\G10000,U3E1\G10002,U3E1\G10014L *27*28	32.7
			CAMPSCL U3E1\HG10000,U3E1\HG10002,U3E1\HG10014L *27*28	32.0
			CAMPSCL #0,#2,#14L *27*29	731.4
			CAMPSCL D2000,D2002,D2014L *27*29	708.1
			CAMPSCL U3E1\G10000,U3E1\G10002,U3E1\G10014L *27*29	711.0
			CAMPSCL U3E1\HG10000,U3E1\HG10002,U3E1\HG10014L *27*29	710.2
			CAMPSCL #0,#2,#14L *27*30	15.3
			CAMPSCL D2000,D2002,D2014L *27*30	12.5
			CAMPSCL U3E1\G10000,U3E1\G10002,U3E1\G10014L *27*30	16.1
			CAMPSCL U3E1\HG10000,U3E1\HG10002,U3E1\HG10014L *27*30	15.4
			CAMPSCL #0,#2,#14L *27*31	221.3
			CAMPSCL D2000,D2002,D2014L *27*31	176.2
			CAMPSCL U3E1\G10000,U3E1\G10002,U3E1\G10014L *27*31	180.3
CAMPSCL U3E1\HG10000,U3E1\HG10002,U3E1\HG10014L *27*31	179.6			
Vision system dedicated function	MVOPEN	Open line	MVOPEN K1,K1000	152.8
			MVOPEN #0,#1	173.5
			MVOPEN D2000,D2001	173.5
			MVOPEN U3E1\G10000,U3E1\G10001	173.9
			MVOPEN U3E1\HG10000,U3E1\HG10001	173.8
	MVLOAD	Load a program	MVLOAD K1,K1000	49.6
			MVLOAD #0,#1	50.5
			MVLOAD D2000,D2001	64.8
			MVLOAD U3E1\G10000,U3E1\G10001	50.6
			MVLOAD U3E1\HG10000,U3E1\HG10001	49.7
	MVTRG	Send an image acquisition trigger	MVTRG K1,K1000	59.0
			MVTRG #0,#1	62.3
			MVTRG D2000,D2001	60.1
			MVTRG U3E1\G10000,U3E1\G10001	69.7
			MVTRG U3E1\HG10000,U3E1\HG10001	61.7
	MVPST	Start a program	MVPST K1,K1000	53.4
			MVPST #0,#1	49.6
			MVPST D2000,D2001	50.6
			MVPST U3E1\G10000,U3E1\G10001	62.4
			MVPST U3E1\HG10000,U3E1\HG10001	61.9

Classifications	Symbol	Instruction	Operation expression	Unit [μs]
Vision system dedicated function	MVIN	Input data	MVIN K1,"A1",#0L,K1000	76.6
			MVIN D2000,D2001,#0L,K1000 ^{*32}	81.6
			MVIN D2000,D2001,#0L,K1000 ^{*33}	60.7
			MVIN U3E1\G10000,U3E1\G10001,U3E1\G10020L,K1000 ^{*33}	65.9
			MVIN U3E1\HG10000,U3E1\HG10001,U3E1\HG10020L,K1000 ^{*33}	65.3
	MVOU	Output data	MVOU K1,"A1",#0L,K1000	60.5
			MVOU D2000,D2001,#0L,K1000 ^{*34}	63.1
			MVOU D2000,D2001,#0L,K1000 ^{*35}	67.0
			MVOU U3E1\G10000,U3E1\G10001,U3E1\G10020L,K1000 ^{*35}	79.4
			MVOU U3E1\HG10000,U3E1\HG10001,U3E1\HG10020L,K1000 ^{*35}	78.2
	MVFIN	Reset a status storage device	MVFIN K1	2.0
			MVFIN #0	2.0
			MVFIN D2000	2.0
			MVFIN U3E1\G10000	2.0
			MVFIN U3E1\HG10000	2.0
	MVCLOSE	Close line	MVCLOSE K1	90.2
			MVCLOSE #0	92.2
			MVCLOSE D2000	92.0
			MVCLOSE U3E1\G10000	91.5
			MVCLOSE U3E1\HG10000	88.8
	MVCOM	Send a command for native mode	MVCOM K1,"GO",#0,K0,K1000	114.9
			MVCOM D2000,D2001,#0,D2100,K1000 ^{*36}	121.3
			MVCOM D2000,D2001,#0,D2100,K1000 ^{*37}	132.2
			MVCOM U3E1\G10000,U3E1\G10002,U3E1\G11000,U3E1\G10001,K1000 ^{*37}	138.9
			MVCOM U3E1\HG10000,U3E1\HG10002,U3E1\HG11000,U3E1\HG10001,K1000 ^{*37}	126.9
Others	EI	Event task enable	EI	0.6
	DI	Event task disable	DI	0.6
	NOP	No operation	NOP	0.2
	BMOV	Block transfer	BMOV #0,#100,K10	2.8
			BMOV D800,D100,K10	2.8
			BMOV U3E1\G10000,U3E1\G10100,K10	5.1
			BMOV U3E1\HG10000,U3E1\HG10100,K10	4.5
			BMOV #0,#100,K100	9.4
			BMOV D800,D100,K100	9.4
			BMOV U3E1\G10000,U3E1\G10100,K100	15.6
			BMOV U3E1\HG10000,U3E1\HG10100,K100	13.0
	FMOV	Same data block transfer	FMOV #0,#100,K10	2.3
			FMOV D800,D100,K10	2.4
FMOV U3E1\G10000,U3E1\G10100,K10			3.0	
FMOV U3E1\HG10000,U3E1\HG10100,K10			2.8	
FMOV #0,#100,K100			9.4	
FMOV D800,D100,K100			9.4	
FMOV U3E1\G10000,U3E1\G10100,K100			5.0	
FMOV U3E1\HG10000,U3E1\HG10100,K100			4.8	

Classifications	Symbol	Instruction	Operation expression	Unit [μs]		
Others	TO	Write device data to buffer memory	TO H0020,H0,#0,K1	4.5		
			TO H0020,H0,D800,K1	4.5		
			TO H0020,H0,U3E1\G10000,K1	5.0		
			TO H0020,H0,U3E1\HG10000,K1	4.9		
			TO H0020,H0,#0,K10	5.4		
			TO H0020,H0,D800,K10	5.4		
			TO H0020,H0,U3E1\G10000,K10	6.8		
			TO H0020,H0,U3E1\HG10000,K10	6.4		
			TO H0020,H0,#0,K100	6.7		
			TO H0020,H0,D800,K100	6.8		
			TO H0020,H0,U3E1\G10000,K100	17.9		
			TO H0020,H0,U3E1\HG10000,K100	15.3		
			TO H0020,H0,#0,K256	9.2		
			TO H0020,H0,D800,K256	9.2		
			TO H0020,H0,U3E1\G10000,K256	37.5		
			TO H0020,H0,U3E1\HG10000,K256	30.8		
			FROM	Read device data from buffer memory	FROM #0,H0060,H0,K1	6.6
					FROM D800,H0060,H0,K1	6.6
	FROM U3E1\G10000,H0060,H0,K1	6.7				
	FROM U3E1\HG10000,H0060,H0,K1	6.7				
	FROM #0,H0060,#0,K10	8.6				
	FROM D800,H0060,H0,K10	8.6				
	FROM U3E1\G10000,H0060,H0,K10	8.7				
	FROM U3E1\HG10000,H0060,H0,K10	8.6				
	FROM #0,H0060,#0,K100	26.0				
	FROM D800,H0060,H0,K100	26.0				
	FROM U3E1\G10000,H0060,H0,K100	23.6				
	FROM U3E1\HG10000,H0060,H0,K100	23.4				
	FROM #0,H0060,H0,K256	55.3				
	FROM D800,H0060,H0,K256	55.3				
	FROM U3E1\G10000,H0060,H0,K256	46.3				
	FROM U3E1\HG10000,H0060,H0,K256	46.3				
	RTO	Write buffer memory data to head module ^{*38}			RTO #4000,#4001,#4002,#0,K1,M0	5.9
					RTO D2000,D2001,D2002,D800,K1,M0	5.2
			RTO U3E1\G12000,U3E1\G12001,U3E1\G12002,U3E1\G10000,K1,M0	7.1		
			RTO U3E1\HG12000,U3E1\HG12001,U3E1\HG12002,U3E1\HG10000,K1,M0	6.7		
			RTO #4000,#4001,#4002,#0,K10,M0	5.0		
			RTO D2000,D2001,D2002,D800,K10,M0	5.0		
			RTO U3E1\G12000,U3E1\G12001,U3E1\G12002,U3E1\G10000,K10,M0	7.1		
			RTO U3E1\HG12000,U3E1\HG12001,U3E1\HG12002,U3E1\HG10000,K10,M0	6.7		
			RTO #4000,#4001,#4002,#0,K100,M0	5.1		
			RTO D2000,D2001,D2002,D800,K100,M0	5.4		
			RTO U3E1\G12000,U3E1\G12001,U3E1\G12002,U3E1\G10000,K100,M0	7.1		
			RTO U3E1\HG12000,U3E1\HG12001,U3E1\HG12002,U3E1\HG10000,K100,M0	6.8		
			RTO #4000,#4001,#4002,#0,K240,M0	5.2		
RTO D2000,D2001,D2002,D800,K240,M0			5.3			
RTO U3E1\G12000,U3E1\G12001,U3E1\G12002,U3E1\G10000,K240,M0			7.4			
RTO U3E1\HG12000,U3E1\HG12001,U3E1\HG12002,U3E1\HG10000,K240,M0			7.1			

Classifications	Symbol	Instruction	Operation expression	Unit [μs]		
Others	RFROM	Read buffer memory data from head module ^{*38}	RFROM #0,#4000,#4001,#4002,K1,M0	5.3		
			RFROM D800,D2000,D2001,D2002,K1,M0	5.0		
			RFROM U3E1\G10000,U3E1\G12000,U3E1\G12001,U3E1\G12002,K1,M0	7.1		
			RFROM U3E1\HG10000,U3E1\HG12000,U3E1\HG12001,U3E1\HG12002,K1,M0	6.8		
			RFROM #0,#4000,#4001,#4002,K10,M0	4.9		
			RFROM D800,D2000,D2001,D2002,K10,M0	4.9		
			RFROM U3E1\G10000,U3E1\G12000,U3E1\G12001,U3E1\G12002,K10,M0	7.0		
			RFROM U3E1\HG10000,U3E1\HG12000,U3E1\HG12001,U3E1\HG12002,K10,M0	6.6		
			RFROM #0,#4000,#4001,#4002,K100,M0	5.0		
			RFROM D800,D2000,D2001,D2002,K100,M0	5.2		
			RFROM U3E1\G10000,U3E1\G12000,U3E1\G12001,U3E1\G12002,K100,M0	7.1		
			RFROM U3E1\HG10000,U3E1\HG12000,U3E1\HG12001,U3E1\HG12002,K100,M0	6.8		
			RFROM #0,#4000,#4001,#4002,K240,M0	5.2		
			RFROM D800,D2000,D2001,D2002,K240,M0	5.3		
			RFROM U3E1\G10000,U3E1\G12000,U3E1\G12001,U3E1\G12002,K240,M0	7.4		
			RFROM U3E1\HG10000,U3E1\HG12000,U3E1\HG12001,U3E1\HG12002,K240,M0	7.1		
			TIME	Time to wait	TIME K1	1.9
					TIME #0	2.2
	TIME D800	2.2				
	TIME U3E1\G10000	3.0				
TIME U3E1\HG10000	2.9					

- *1 Number of searches of data conversion for scaling is 10 times
- *2 Number of searches of data conversion for scaling is 100 times
- *3 Number of searches of data conversion for scaling is 1000 times
- *4 Actual input/actual output is set
- *5 (S) in IF - ELSE - IEND are set by true data
- *6 (S) in IF - ELSE - IEND are set by false data
- *7 For SELECT - CASE(S1) - CEND CASE(S2) - CEND CELSE - CEND SEND, (S1) are set by true data
- *8 For SELECT - CASE(S1) - CEND CASE(S2) - CEND CELSE - CEND SEND, (S1) are set by false data and (S2) are set by true data
- *9 For SELECT - CASE(S1) - CEND CASE(S2) - CEND CELSE - CEND SEND, (S1) and (S2) are set by false data
- *10 1-axis linear positioning control
- *11 4-axes linear interpolation control
- *12 1-point machine program operation
- *13 128-point machine program operation
- *14 256-point machine program operation
- *15 The cam data is in the stroke ratio data format
- *16 The cam data is in the coordinate data format
- *17 The cam resolution is 256, and the auto-generation option is set to the S-curve acceleration/deceleration system.
- *18 The cam resolution is 8192, and the auto-generation option is set to the S-curve acceleration/deceleration system.
- *19 The cam resolution is 32768, and the auto-generation option is set to the S-curve acceleration/deceleration system.
- *20 The cam auto-generation type is set to easy stroke ratio cam, 8 sections are set, the cam resolution is 256, the cam curve is distorted sine.
- *21 The cam auto-generation type is set to easy stroke ratio cam, 8 sections are set, the cam resolution is 8192, the cam curve is distorted sine.
- *22 The cam auto-generation type is set to easy stroke ratio cam, 8 sections are set, the cam resolution is 32768, the cam curve is distorted sine.
- *23 The cam auto-generation type is set to easy stroke ratio cam, 32 sections are set, the cam resolution is 256, the cam curve is distorted sine.
- *24 The cam auto-generation type is set to easy stroke ratio cam, 32 sections are set, the cam resolution is 8192, the cam curve is distorted sine.
- *25 The cam auto-generation type is set to easy stroke ratio cam, 32 sections are set, the cam resolution is 32768, the cam curve is distorted sine.
- *26 The cam position calculation type is set to the cam axis current feed value calculation.
- *27 The cam position calculation type is set to the cam axis current value per cycle calculation.
- *28 The cam data is in the stroke ratio data format, the cam resolution is 256, and the calculation is performed with the midpoint (128).
- *29 The cam data is in the stroke ratio data format, the cam resolution is 8192, and the calculation is performed with the midpoint (4096).
- *30 The cam data is in the coordinate data format, the coordinates number is 256, and the calculation is performed with the midpoint (128).
- *31 The cam data is in the coordinate data format, the coordinates number is 8192, and the calculation is performed with the midpoint (4096).
- *32 (S2) in MVIN (S1), (S2), (D) and (S3) are set by 2 bytes character string.



- *33 (S2) in MVIN (S1), (S2), (D) and (S3) are set by 32 bytes character string.
- *34 (S2) in MVOUT (S1), (S2), (S3) and (S4) are set by 2 bytes character string.
- *35 (S2) in MVOUT (S1), (S2), (S3) and (S4) are set by 32 bytes character string.
- *36 (S2) in MVCOM (S1), (S2), (D), (S3) and (S4) are set by 2 bytes character string.
- *37 (S2) in MVCOM (S1), (S2), (D), (S3) and (S4) are set by 191 bytes character string.
- *38 This is the Motion CPU processing time, and does not include the time to complete data transfer.

Transition conditional expressions

Classifications	Symbol	Instruction	Operation expression	Unit [μ s]
Bit device status	(None)	ON (Normally open contact) (Completion of condition)	M0	0.6
			X100	1.3
			X20* ¹	6.7
			U3E1\G10000.0	1.8
			U3E1\HG10000.0	1.6
	!	OFF (Normally closed contact) (Completion of condition)	!M0	0.8
			!X100	1.4
			!X20* ¹	6.9
			!U3E1\G10000.0	1.9
			!U3E1\HG10000.0	1.8
Logical operation	*	Logical AND	M0*M1	1.4
			X100*X101	2.1
			X20*X20* ¹	11.1
			U3E1\G10000.0*U3E1\G10000.1	2.9
			U3E1\HG10000.0*U3E1\HG10000.1	2.7
	+	Logical OR	M0+M1	1.3
			X100+X101	2.1
			X20+X20* ¹	11.1
			U3E1\G10000.0+U3E1\G10000.1	2.9
			U3E1\HG10000.0+U3E1\HG10000.1	2.7
Comparison operation	==	Equal to (Completion of condition)	#0==#1	1.6
			D800==D801	1.5
			U3E1\G10000==U3E1\G10001	2.9
			U3E1\HG10000==U3E1\HG10001	2.7
			#0L==#2L	2.0
			D800L==D802L	1.7
			U3E1\G10000L==U3E1\G10002L	3.1
			U3E1\HG10000L==U3E1\HG10002L	2.8
			#0F==#4F	1.8
			D800F==D804F	1.8
	U3E1\G10000F==U3E1\G10004F	3.1		
	U3E1\HG10000F==U3E1\HG10004F	2.9		
	!=	Not equal to (Completion of condition)	#0!=#1	1.6
			D800!=D801	1.6
			U3E1\G10000!=U3E1\G10001	2.9
			U3E1\HG10000!=U3E1\HG10001	2.7
			#0L!=#2L	1.8
			D800L!=D802L	1.7
			U3E1\G10000L!=U3E1\G10002L	3.1
			U3E1\HG10000L!=U3E1\HG10002L	2.8
#0F!=#4F			3.5	
D800F!=D804F			1.8	
U3E1\G10000F!=U3E1\G10004F	3.2			
U3E1\HG10000F!=U3E1\HG10004F	2.9			

Classifications	Symbol	Instruction	Operation expression	Unit [μ s]
Comparison operation	<	Less than (Completion of condition)	#0<#1	1.6
			D800<D801	1.5
			U3E1\G10000<U3E1\G10001	2.9
			U3E1\HG10000<U3E1\HG10001	2.6
			#0L<#2L	1.8
			D800L<D802L	1.7
			U3E1\G10000L<U3E1\G10002L	3.2
			U3E1\HG10000L<U3E1\HG10002L	2.9
			#0F<#4F	1.8
			D800F<D804F	1.8
			U3E1\G10000F<U3E1\G10004F	3.1
			U3E1\HG10000F<U3E1\HG10004F	2.9
	<=	Less than or equal to (Completion of condition)	#0<=#1	1.6
			D800<=D801	1.6
			U3E1\G10000<=U3E1\G10001	3.0
			U3E1\HG10000<=U3E1\HG10001	2.7
			#0L<=#2L	1.8
			D800L<=D802L	1.8
			U3E1\G10000L<=U3E1\G10002L	3.2
			U3E1\HG10000L<=U3E1\HG10002L	2.9
			#0F<=#4F	1.9
			D800F<=D804F	1.8
			U3E1\G10000F<=U3E1\G10004F	3.2
			U3E1\HG10000F<=U3E1\HG10004F	3.0
	>	More than (Completion of condition)	#0>#1	1.6
			D800>D801	1.5
			U3E1\G10000>U3E1\G10001	2.9
			U3E1\HG10000>U3E1\HG10001	2.6
			#0L>#2L	1.7
			D800L>D802L	1.7
			U3E1\G10000L>U3E1\G10002L	3.1
			U3E1\HG10000L>U3E1\HG10002L	2.9
			#0F>#4F	1.8
			D800F>D804F	1.7
			U3E1\G10000F>U3E1\G10004F	3.1
			U3E1\HG10000F>U3E1\HG10004F	2.9
>=	More than or equal to (Completion of condition)	#0>=#1	1.6	
		D800>=D801	1.5	
		U3E1\G10000>=U3E1\G10001	2.9	
		U3E1\HG10000>=U3E1\HG10001	2.6	
		#0L>=#2L	1.7	
		D800L>=D802L	1.7	
		U3E1\G10000L>=U3E1\G10002L	3.1	
		U3E1\HG10000L>=U3E1\HG10002L	2.8	
		#0F>=#4F	1.8	
		D800F>=D804F	1.7	
		U3E1\G10000F>=U3E1\G10004F	3.1	
		U3E1\HG10000F>=U3E1\HG10004F	2.9	

*1 Actual input/actual output is set.

Processing time by the combination F and G (program described in F/G is NOP)

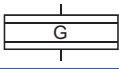
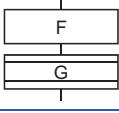
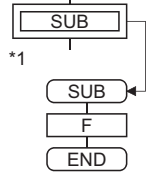
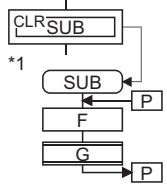
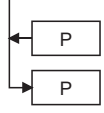
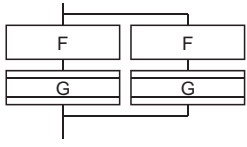
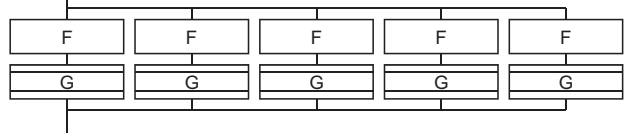
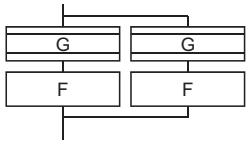
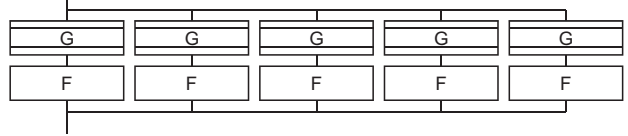
Name			Motion SFC chart	Unit [μ s]	
F alone				8.0	
G alone				7.5	
F+G				9.0	
GSUB				14.0	
CLR				10.0	
JMP/coupling				7.0	
Parallel branch	2 Pcs.	At branch		13.0	
		At coupling		10.5	
	5 Pcs.	At branch			28.0
		At coupling			10.5
Selective branch	2 Pcs.		28.5		
	5 Pcs.		32.5		

*1 Varies greatly with the started or cleared program.

A

Point

Long processing time may cause a Motion CPU WDT error or servo fault. Especially for the Motion SFC programs run by event/NMI tasks, take care so that the processing time will not be too long (the processing time will not exceed the operation cycle).

Processing time of advanced synchronous control dedicated functions

The operation processing times for advanced synchronous control dedicated functions are shown below. Operation processing times can vary substantially depending on the number of cams and where they are saved. The values contained in the following tables should therefore be taken as a set of general guidelines to processing time rather than as being strictly accurate.

CAMRD instruction processing time

■Data format (stroke ratio cam)

Cam resolution	Processing time [ms]		
	Not saved (open area)	Standard ROM	SD memory card
256	0.02	54	82
4096	0.58	181	406
32768	3.76	2170	411

■Data format (coordinate)

Cam resolution	Processing time [ms]		
	Not saved (open area)	Standard ROM	SD memory card
256	0.04	53	120
4096	1.14	591	139
32768	4.11	2410	621

CAMWR instruction processing time

■Data format (stroke ratio cam)

Cam resolution	Processing time [ms]		
	Not saved (open area)	Standard ROM	SD memory card
256	0.02	42	76
4096	0.04	194	109
32768	3.81	2497	423

■Data format (coordinate)

Cam resolution	Processing time [ms]		
	Not saved (open area)	Standard ROM	SD memory card
256	0.04	55	106
4096	0.96	291	152
32768	4.18	3641	641

CAMMK instruction processing time

■Cam for rotary cutter

Cam resolution	Processing time [ms]		
	Not saved (open area)	Standard ROM	SD memory card
256	0.26	34	74
1024	0.51	31	70
4096	2.7	32	71
32768	23	53	87

■ Easy stroke ratio cam

Cam resolution	Section	Processing time [ms]		
		Not saved (open area)	Standard ROM	SD memory card
256	1	0.76	34	74
	16	0.88	31	65
	32	0.92	32	65
4096	1	8.9	39	74
	16	5.9	37	71
	32	5.9	39	71
32768	1	69	100	133
	16	47	78	112
	32	47	80	112

■ Advanced stroke ratio cam

- Curve type (constant speed)

Cam resolution	Section	Processing time [ms]		
		Not saved (open area)	Standard ROM	SD memory card
256	1	1.2	42	73
	32	0.65	33	68
	180	1.1	52	71
	360	1.7	77	91
4096	1	8.9	42	77
	32	6.1	39	73
	180	6.6	58	76
	360	7.1	81	102
32768	1	70	104	134
	32	47	81	113
	180	47	99	114
	360	48	121	139

- Processing time by curve type (cam resolution: 256, number of sections: 1)

Cam resolution	Processing time [ms]		
	Not saved (open area)	Standard ROM	SD memory card
Constant speed	1.1	36	61
Constant acceleration	0.91	31	53
Distorted trapezoid	2.5	32	64
Distorted sine	2.5	34	55
Distorted constant speed	3.1	33	60
Cycloid	1.4	30	61
5th curve	1	32	60
Trapezoid	3.3	33	60
Reverse trapezoid	3.5	33	56
Double hypotenuse	1.9	32	60
Reverse double hypotenuse	1.9	32	60
Single hypotenuse	1.5	30	57

CAMPSCL instruction processing time

Cam resolution	Cam position calculation type	Processing time [ms]
256	Cam axis current feed value calculation	0.01
	Cam axis current value per cycle calculation	0.003
32768	Cam axis current feed value calculation	0.011
	Cam axis current value per cycle calculation	0.008

Deploying time for cam data

The time it takes to deploy one cam file from the standard ROM to the open area is shown below. The search time can vary substantially depending on the cam file that is stored, and the number of other files stored. The values contained in the following tables should therefore be taken as a set of general guidelines to processing time rather than as being strictly accurate.

Stroke ratio data format

Cam resolution	Number of registered cams	Processing time [ms]
256	16	8.5
	1024	20
32768	2	118
	128	125

Coordinate data format

Cam resolution	Number of registered cams	Processing time [ms]
256	16	12
	1024	20
32768	2	612
	128	614

Cam auto-generation

■Cam for rotary cutter

Cam resolution	Number of registered cams	Processing time [ms]
1024	256	33
	1024	94

■Easy stroke ratio cam

Cam resolution	Number of registered cams	Number of sections	Processing time [ms]
256	256	1	36
	1024		94

■Advanced stroke ratio cam

Cam resolution	Number of registered cams	Number of sections	Processing time [ms]
256	1024	1	103
		180	93
		360	105
4096	1024	1	107
		180	112
		360	115
32768	128	1	103
		180	78
		360	83

Processing time of Motion dedicated PLC instruction

Classifications	Instruction (Condition)	Symbol	Processing time [μ s]	
			R04CPU/R08CPU/R16CPU/R32CPU/ R120CPU/R08PCPU/R16PCPU/ R32PCPU/R120PCPU	
			Min.	Max.
Motion dedicated PLC instruction	Start request of the specified Motion SFC program	D.SFCS	38.0	77.0
		M.SFCS	29.0	68.0
	Start request of the specified servo program	D.SVST	48.0	86.0
		M.SVST	38.0	76.0
	Direct positioning start request (data points = 14 points)	D.SVSTD	62.0	99.0
		M.SVSTD	57.0	91.0
	Current value change request of the specified axis	D.CHGA	48.0	86.0
		M.CHGA	39.0	74.0
	Current value change request of the specified command generation axis	D.CHGAS	48.0	86.0
		M.CHGAS	38.0	75.0
	Speed change request of the specified axis	D.CHGV	48.0	86.0
		M.CHGV	38.0	75.0
	Speed change request of the specified command generation axis	D.CHGVS	48.0	86.0
		M.CHGVS	38.0	75.0
	Torque control value change request of the specified axis	D.CHGT	48.0	86.0
		M.CHGT	39.0	76.0
	Machine program operation start request (data points = 78 points)	D.MCNST	55.0	83.0
		M.MCNST	45.0	73.0
	Write bit operation to the bit device of another Motion CPU	D.BITWR	47.0	84.0
		M.BITWR	38.0	74.0
Execute request of an event task of Motion SFC program	D.GINT	40.0	77.0	
	M.GINT	31.0	68.0	

A

Appendix 2 Sample Program

Sample programs using R32MTCPU are shown below.

The sample programs in this section are explained in the "Q series Motion compatible device assignment" device assignment method.

Motion control example by Motion SFC program

The Motion SFC program composition example to execute motion control

This sample program example is described for every following function.

■Function list of sample program

No.	Item	Description
1	Forced stop	When the forced stop input assigned to X0 is on, all axes turn on, and motion control is executed. When the forced stop input turn off, servo amplifier is made to forced stop, and motion control is suspended, and actual output (Y) turn off.
2	Motion control	Motion control is executed according to the condition of X and X2 in each following mode. <ul style="list-style-type: none">• X2: OFF X1: OFF JOG mode• X2: OFF X1: ON Manual pulse generator mode• X2: ON X1: OFF Home position return mode• X2: ON X1: ON Programming operation mode
3	JOG mode	The following JOG operation is executed when each signal of X3 to X6 is turned on. <ul style="list-style-type: none">• X3: 1 axis JOG forward rotation• X4: 1 axis JOG reverse rotation• X5: 2 axes JOG forward rotation• X6: 2 axes JOG reverse rotation
4	Manual pulse generator mode	The following the manual pulse generator operation is executed. <ul style="list-style-type: none">• Manual pulse generator operation of 1 axis is executed with the manual pulse generator P1.• Manual pulse generator operation of 2 axes is executed with the manual pulse generator P1.
5	Home position return mode	The following home position return is executed. <ul style="list-style-type: none">• When X3 is on, the home position return of 1 axis is executed.• When X4 is on, the home position return of 2 axes is executed.
6	Programming operation mode	The following program operation is executed. <ul style="list-style-type: none">• When X3 detects OFF to ON, axis No.1 locates and 1000[ms] standing by, after the location of axis No.2 is executed.• When X4 turn on, axis No.1, 2 locates of the linear control and in-position check is executed, after the location of axis No.2 is executed, the program stands by until No.1, 2 locates of the linear control is executed at a double speed in the opposition direction and X4 turns off.

Contents processing of the Motion SFC program

■Motion SFC program list

No.	Program name	Task	Automatic operation	Number of connective transitions	Contents of processing
20	Main	Normal	Start	3	<ul style="list-style-type: none"> This program starts automatically at the time of run of Motion CPU, and it is always executed. When a forced stop is cancelled, a subroutine starts a "No.110: Motion control". "No.110: Motion control" is stopped at the time of the forced stop, and real output (Y) is turned off.
110	Motion control	Normal	Not start	3	<ul style="list-style-type: none"> All axes servo on. The call of the subroutine of the following program is executed by the condition of X1, X2. (1) X2: OFF X1: OFF No.120: JOG (2) X2: OFF X1: ON No.130: Manual pulse generator (3) X2: ON X1: OFF No.140: Home position return (4) X2: ON X1: ON No.150: Programming operation
120	JOG	Normal	Not start	3	<ul style="list-style-type: none"> The JOG operation speed of 1 axis and 2 axes is set. 1 axis JOG forward command is turned on when X3 is on, and the reverse command is turned on when X4 is on. 2 axes JOG forward command is turned on when X5 is on, and the reverse command is turned on when X6 is on. The above are repeated when X2/X1 are off, when X2/X1 are not off, the JOG forward and reverse command of 1 axis and 2 axes are turned off and the program is ended.
130	Manual pulse generator	Normal	Not start	3	<ul style="list-style-type: none"> 1 pulse input magnification of the 1 axis and 2 axes is set up. 1 axis is controlled with P1, and set up to control 2 axes with P2, and Manual pulse generator enable flag of P1, P2 is turned on. When except for X2: OFF, X1: ON (Manual pulse generator mode), Manual pulse generator enable flag of P1, P2 is turned off, and a program is ended.
140	Home position return	Normal	Not start	3	<ul style="list-style-type: none"> "K140: The home position return of 1 axis" is started when X3 is on, "K141: The home position return of 2 axes" is started when X4 is on. X2: ON, X1: The program is ended when they become to except for off (Home position return mode).
150	Programming operation	Normal	Not start	3	<ul style="list-style-type: none"> When X3 detects OFF to ON, after positioning of 1 axis, standing by for 1000[ms] and positioning of 2 axes is executed. When X4 turn on, after positioning of linear interpolation in-position check is executed, positioning of axis No.1, 2 linear interpolation is executed at a double speed in the opposition direction, and it stand by until X4 turned off. X2: ON, X1: The program is ended when they become to except for ON (Programming operation mode).

■No.20: Main

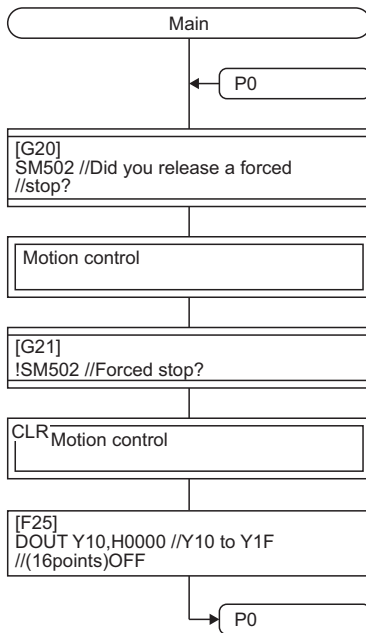

When a forced stop is released, a subroutine starts "No.110: Motion control". (Because the next step is a shift, it becomes a subroutine start, and the next step is executed at the same time with subroutine practice, too.)

"No.110: Motion control" is made to stop at the time of the forced stop, and (The program that a subroutine call is executed from No.110 stops, too.) actual output (Y) is turned off.

- *: The program that a subroutine was started is made to stop if necessary when a subroutine start program is added because it does not stop.
- *: Real output is turned off if necessary.
- *: The occurrence detection of servo error and so on is added to the stop status with forced stop if necessary.

When a forced stop is released, it is the structure which starts the program which does motion control from the initials again by sample program. Therefore it is the system example that motion control is resumed when a forced stop release is executed after it stops forced for a while.

■No.110: Motion control

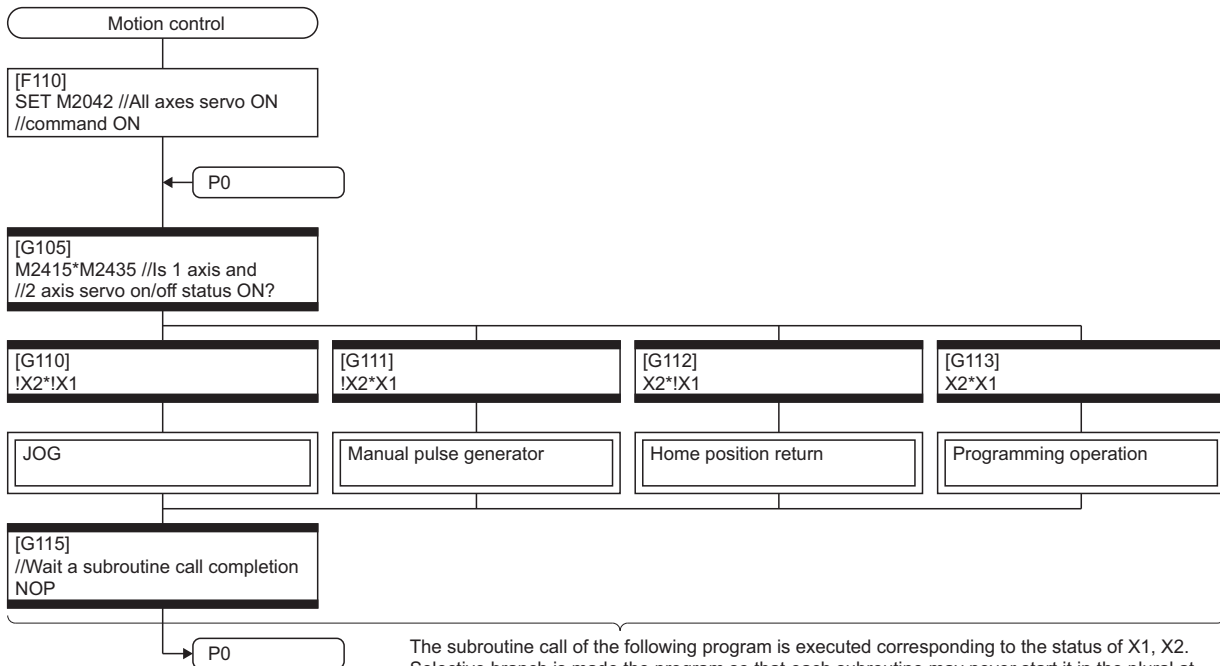

The subroutine call of the following program is executed corresponding to the status of X1, X2. Selective branch is made the program so that each subroutine may never start it in the plural at the same time.

And, each subroutine makes the next step "WAIT" to become a subroutine call to make it stop when this program is suspended by the clear step of "No.20: Main", too.

Condition of X1, X2		Subroutine call program	
X2	X1	No.	Program name
OFF	OFF	120	JOG
OFF	ON	130	Manual pulse generator
ON	OFF	140	Home position return
ON	ON	150	Programming operation

■No.120: JOG

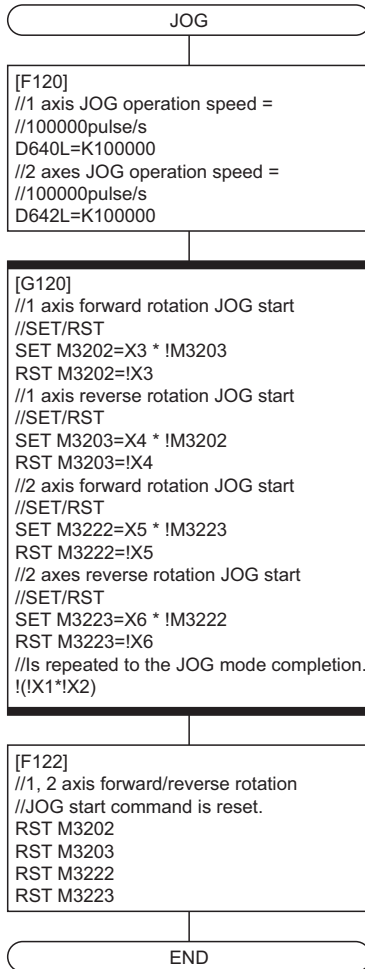

When each signal of X3 to X6 is turned on/off, which the correspondences JOG command device is SET/RST. It makes forward rotation JOG start of the same axis and a reverse rotation JOG start from making turned on at the same time.

Signal name	Correspond with JOG command device
X3	M3202 (1 axis forward rotation JOG)
X4	M3203 (1 axis reverse rotation JOG)
X5	M3222 (2 axis forward rotation JOG)
X6	M3223 (2 axis reverse rotation JOG)

*: The ON/OFF distinction of each signal can be described with Y/N transition. But, processing time can be shortened more the number of steps when it was described as the following in the case of the processing which could be described only with SET=/RST= because it is made low.

Forward rotation/reverse rotation JOG status of 1, 2 axis is turned off at the time of the JOG mode completion not to continue a JOG movement after it moves to other mode of the safety.

■No.130: Manual pulse generator

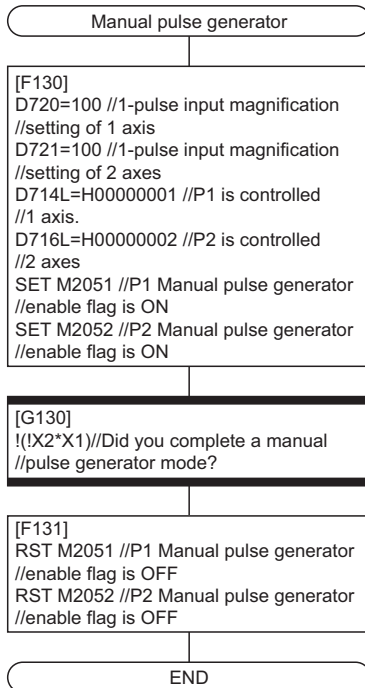

The setup of the following is executed to do manual pulse generator operation of P1 with 1 axis/P2 with 2 axis.

- Setting of 1-pulse input magnification of the 1 axis and 2 axis.
- Manual pulse generator axis No. setting register is setup to control of P1 with 1 axis/P2 with 2 axis.
- Manual pulse generator axis enable flag of P1, P2 is turned on.

1, 2 axis Manual pulse generator enable flag turned off at the time of the JOG mode completion not to continue a manual pulse generator operation after it moves to other mode of the safety.

■No.140: Home position return

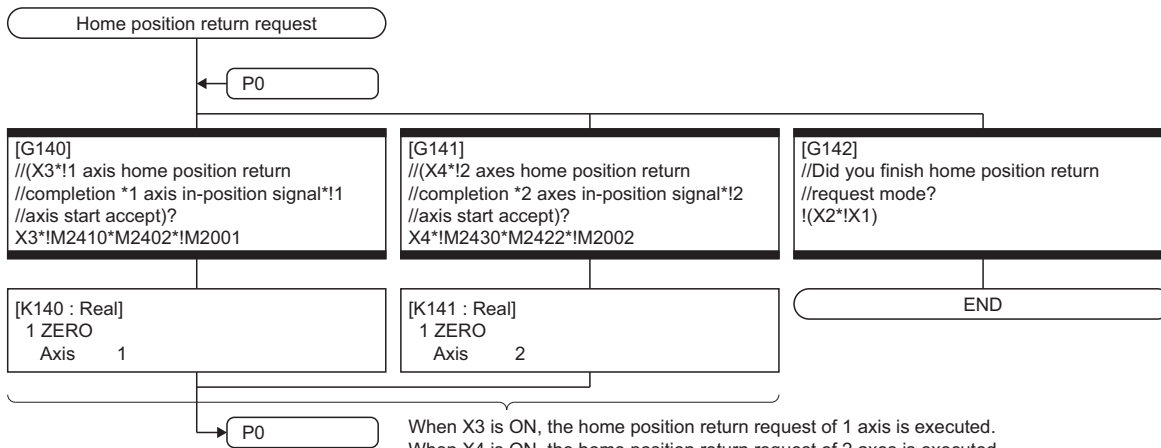

When X3 is ON, the home position return request of 1 axis is executed.
 When X4 is ON, the home position return request of 2 axes is executed.
 At this time in-position signal ON and start accept OFF confirmed, and home position return request program is started.

*: This program is the structure which does not have WAIT that it waits for the completion of the home position return in the next of the motion control step, because it possible a thing during "K140" practice and "K141" are started.
 (You must take the initial start of each axis to interlock condition to prevent the double start of K140 and K141.)

No.150: Programming operation

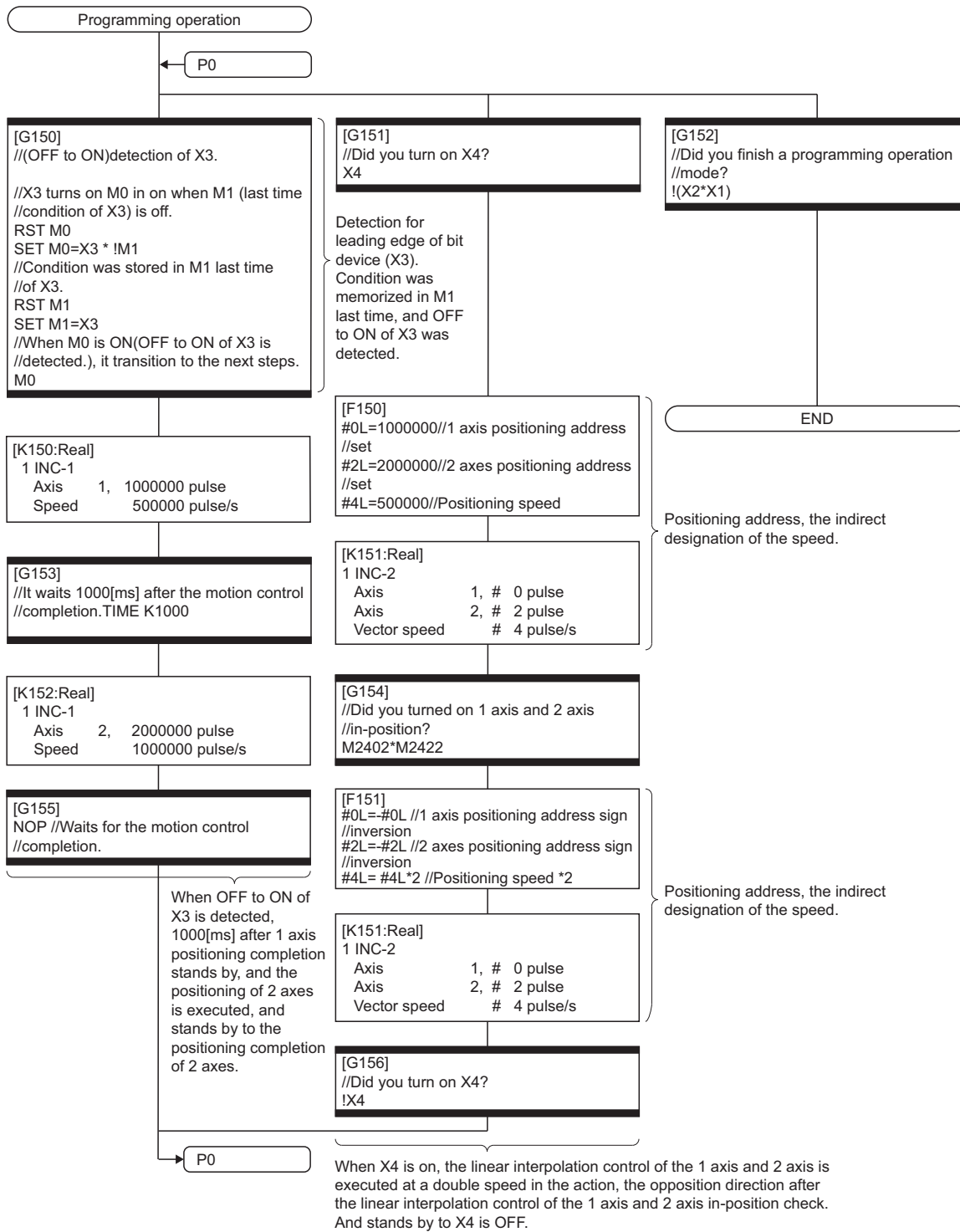

Module configuration data of the Motion CPU

Module configuration is shown below.

	Start I/O No.	Series	Operation Type	Module Type	Operation Point	Control CPU	Inter-module Synchronization Setting	Setting Item
Main - Power Supply	-	-	Power Supply	-	-	-	-	-
Main - CPU	3E00	IQ-R	CPU	R04CPU	-	-	-	-
Main - CPU	3E10	IQ-R	CPU(Self CPU)	R32MTCPU	-	-	-	-
Main - I/O 1	0000	IQ-R	Input	RX40C7	16 Point	CPU 2	-	Detailed
Main - I/O 2	0010	IQ-R	Output	RY40NTSP	16 Point	CPU 2	-	Detailed
Main - I/O 3	0020	IQ-R	Intelligent	RD62D2	16 Point	CPU 2	-	Detailed
Main - I/O 4	-	-	-	-	-	-	-	-
Main - I/O 5	-	-	-	-	-	-	-	-
Main - I/O 6	-	-	-	-	-	-	-	-
Main - I/O 7	-	-	-	-	-	-	-	-

Points Occupied by Empty Slot Point

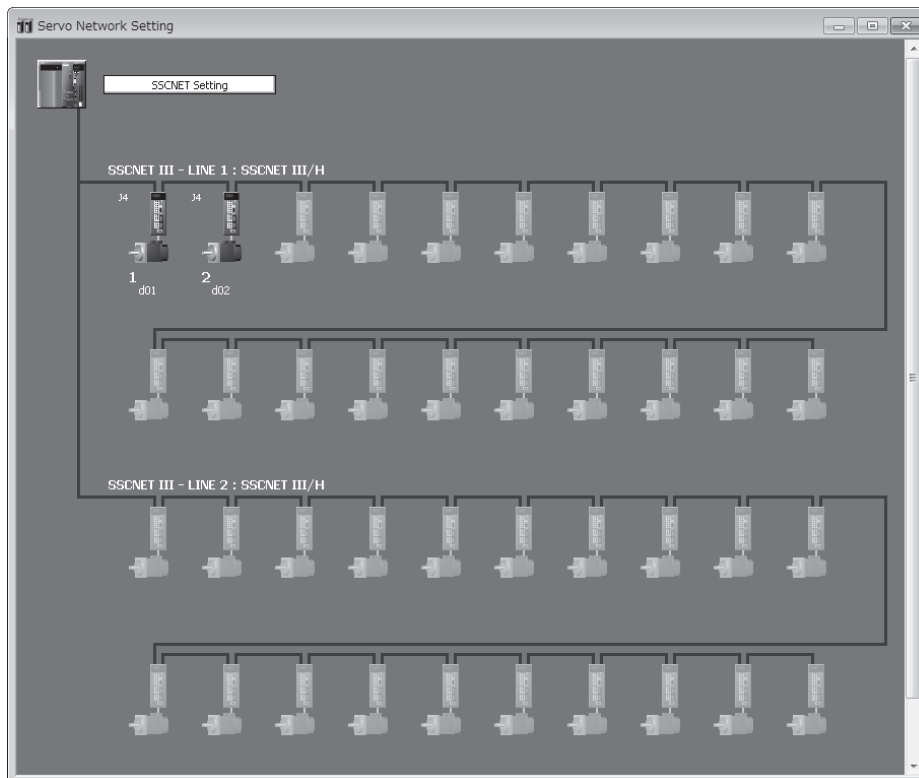

Continuation execution example at the subroutine re-start by the Motion SFC program

Explanation of the operation

This is the program example which execute continuously from the motion control step which stopped on the way when it re-started after stopping the subroutine program with the clear step during the motion control is running. The servo is turned on by the forced stop release and the positioning control of the 2 axes linear interpolation is executed when X4 is ON in this program. One cycle operation is completed after confirmation that X4 became OFF. When the forced stop is executed during the positioning operating, the positioning operation is interrupted and the servomotor is stopped. It is resumed from the interrupted positioning operation when the forced stop was released next. Continuation execution of the subroutine re-start is executed by this program example by the following processing.

- While motion control with the subroutine is executed, it is memorized whether the positioning of which motion control step was completed in the user device.
- The subroutine re-start is resumed from the motion control step that was stopped based on the information memorized above.
- A motion control step should locate absolute to cope with it when it is resumed after it stops on the way of the positioning.
- "[St.1060] Positioning start complete (M2401+20n)" is used for the decision, whether servomotor is stopped during the positioning.

Contents of processing the Motion SFC program

■ Motion SFC program list

No.	Program name	Task	Automatic operation	Number of connective transitions	Contents of processing										
20	Main	Normal	Start	3	<ul style="list-style-type: none"> • This program starts automatically at the time of RUN of Motion CPU, and it is always executed. • "0" is set on the continuation point (#100: user device) as an initial value. • The subroutine starts a "No.160: Re-start continuation" after all axes servo are turned on and servo on of 1 axis and 2 axes is confirmed when a forced stop is released. • "No.160: Re-start continuation" is stopped at the time of the forced stop, and actual output (Y) is turned off. 										
160	Restart continuation	Normal	Not start	3	<ul style="list-style-type: none"> • This program jumps corresponding to the value of the continuation point (#100) of the following (1) to (9). <table border="1" data-bbox="810 1384 1082 1563"> <thead> <tr> <th>#100</th> <th>Jump destination</th> </tr> </thead> <tbody> <tr> <td>0</td> <td>Following (1)</td> </tr> <tr> <td>10</td> <td>Following (3)</td> </tr> <tr> <td>20</td> <td>Following (5)</td> </tr> <tr> <td>30</td> <td>Following (8)</td> </tr> </tbody> </table> <ul style="list-style-type: none"> • The following motion control is executed. <ol style="list-style-type: none"> (1) This program stands by until X4 is turned on. (2) "10" is set on continuation point (#100). (3) 1 axis, 2 axes are located in (0,0) in the linear control (absolute 2 axes positioning). (4) Positioning completion signal on of 1 axis, 2 axes is confirmed, and "20" is set on the continuation point (#100). (5) In-position on of 1 axis and 2 axes is confirmed. (6) 1 axis, 2 axes are located in (1000000, 2000000) in the linear control (absolute 2 axes positioning). (7) Positioning completion signal on of 1 axis, 2 axes is confirmed, and "30" is set on the continuation point (#100). (8) This program stands by until X4 is turned off. (9) "0" is set on continuation point (#100). 	#100	Jump destination	0	Following (1)	10	Following (3)	20	Following (5)	30	Following (8)
#100	Jump destination														
0	Following (1)														
10	Following (3)														
20	Following (5)														
30	Following (8)														

A

■No.20: Main

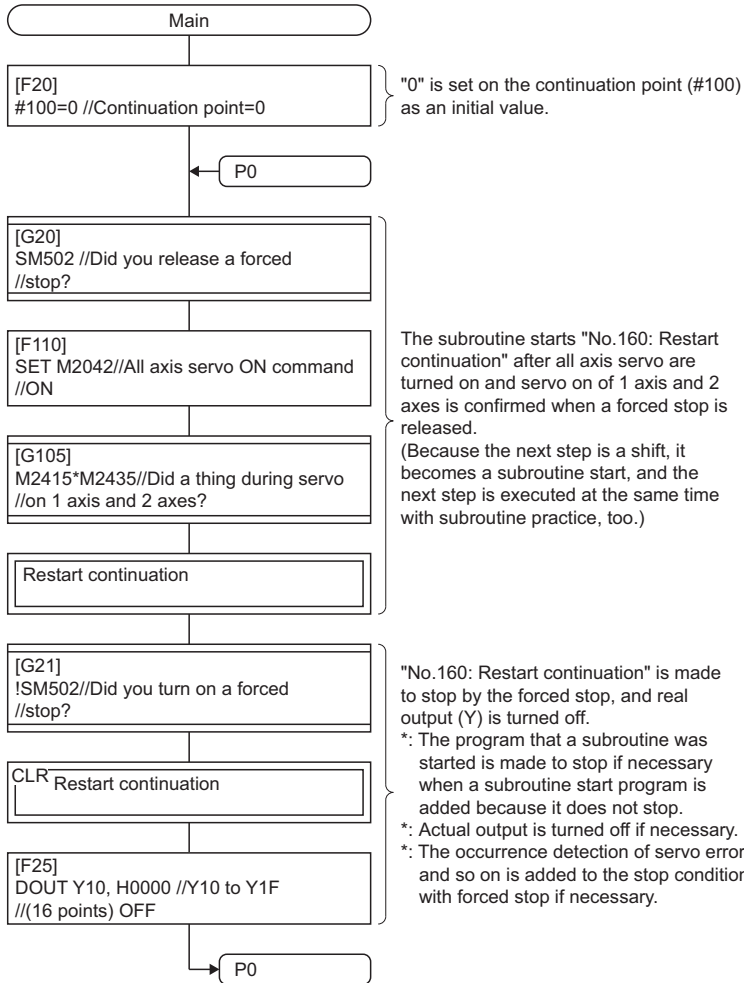

When a forced stop is released, it is the structure which starts the program which does motion control from the initials again by sample program. Therefore it is the system example that motion control is resumed when a forced stop release is executed after it stops forced for a while.

■No.160: Restart continuation

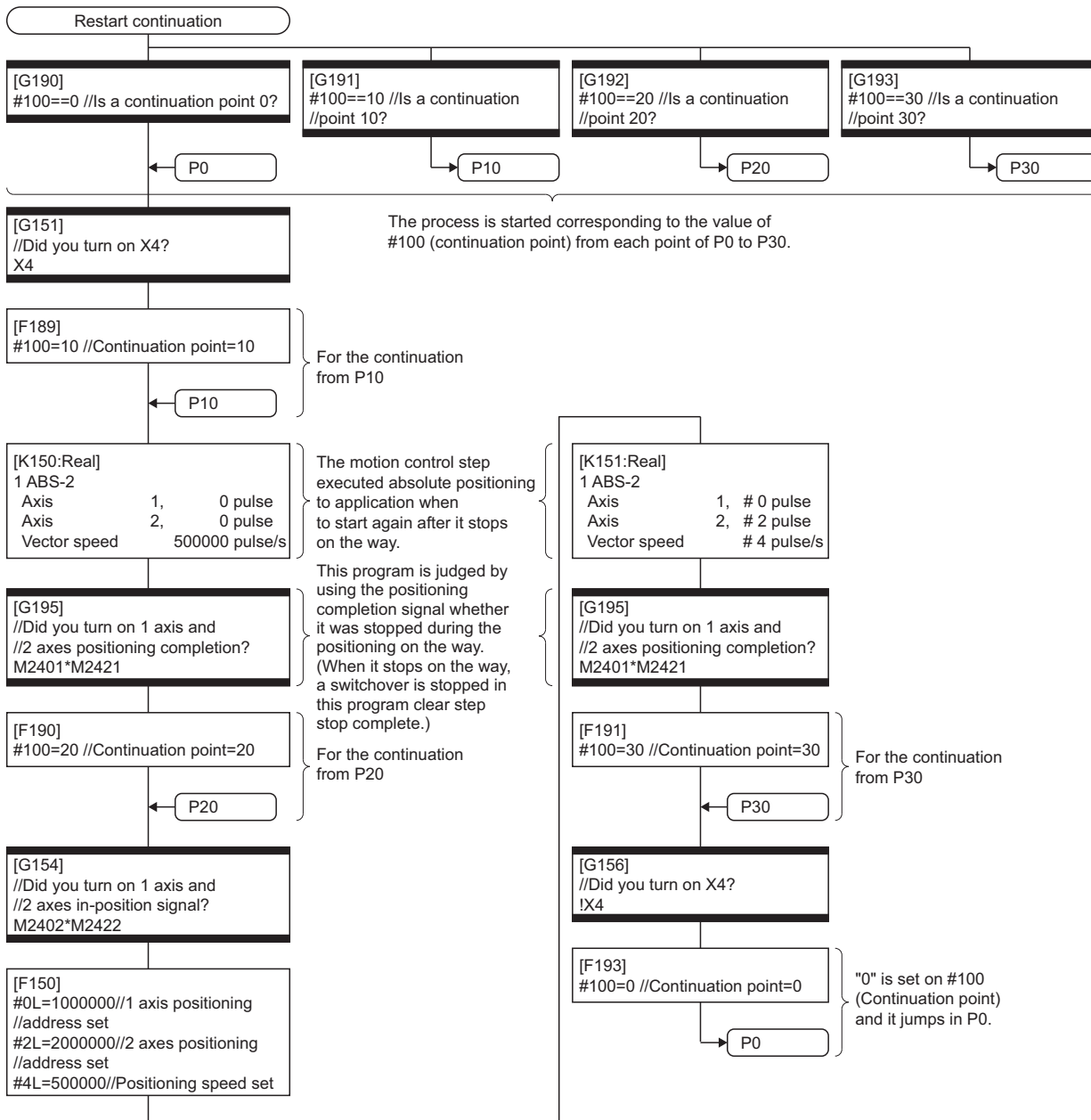

Continuation execution example after the stop by the Motion SFC program

The explanation of the operation

The program example that the Motion SFC program is stopped by external input signal ON for the forced stop from the input module, and it is executed continuously by external signal OFF for the stop is shown below. The servo is turned on by the forced stop release and the positioning control of the 2 axes linear interpolation is executed when X4 is ON in this program. One cycle operation is completed after confirmation that X4 became OFF. When X5 turns ON during the positioning operating, the positioning operation is stopped by the stop instruction and it is resumed from the interrupted positioning operation at turning X5 on. The transition to the next step is not executed during X5 is ON in the WAIT transition. When the forced stop is executed during the positioning operating, the positioning operation is interrupted and the servomotor is stopped. It is resumed from the interrupted positioning operation when the forced stop was released next. Continuation execution of the stop

and stop after is executed by this program example by the following processing.

- While X5 turns it on, it is made to turn on a "[Rq.1140] Stop command (M3200+20n)" and an internal relay (M100) for the stop.
- While X5 turns it off, it is made to turn off a "[Rq.1140] Stop command (M3200+20n)" and an internal relay (M100) for the stop.
- A motion control step does absolute position to cope with it when it is resumed after it stops on the way of the positioning.
- "[St.1060] Positioning start complete (M2401+20n)" is used for the decision whether it is stopped during the positioning on the way.
- The motion control step is resumed after it waits to turn it off, when it was stepped during positioning.
- "The internal relay (M100) for the stop turn off." is substituted for the WAIT transition condition that you must stop.

Contents of processing Motion SFC program

■ Motion SFC program list

No.	Program name	Task	Automatic operation	Number of connective transitions	Contents of processing
20	Main	Normal	Start	3	<ul style="list-style-type: none"> • This program starts automatically at the time of RUN of Motion CPU, and it is always executed. • The initials condition of the internal relay (M100) for the stop is turned on. • The subroutine starts "No.170: Stop". • The subroutine starts "No.150: Programming operation". • When an forced stop is released, all axes servo are turned on. • Turns off actual output (Y) at the time of the forced stop.
170	Stop	Normal	Not start	3	<p>(1) When a stop input signal (X5) from the input unit is off, the treatment of the following (2) is executed, and 1 axis and 2 axes executed the following (3) during servo on in the case of the one except for it.</p> <p>(2) 1 axis and 2 axes stop command are turned off, and an internal relay (M100) for the stop is turned off.</p> <p>(3) 1 axis and 2 axes stop command are turned on, and an internal relay (M100) for the stop is turned on.</p>
150	Program operation	Normal	Not start	3	<ul style="list-style-type: none"> • The following motion control is executed. (1) This program stands by until X4 is turned on. (2) 1 axis and 2 axes are located in (0,0) in the linear interpolation control (absolute 2 axes positioning). (3) Positioning completion signal on of 1 axis and 2 axes are confirmed. (4) In-position on of 1 axis and 2 axes are confirmed. (5) 1 axis and 2 axes are located in (1000000, 2000000) in the linear control (absolute 2 axes positioning). (6) Positioning completion signal on of 1 axis and 2 axes are confirmed. (7) This program stands by until X4 is turned off. • When a positioning completion signal of the above (3) and (6) is off, it waits to turn off, and (When a positioning was suspended on the way.) execute the motion control step (2) or (5) again. • Until an internal relay (M100) for the stop turns it on, it does not move to the next step of the above (1) and (7).

■No.20: Main

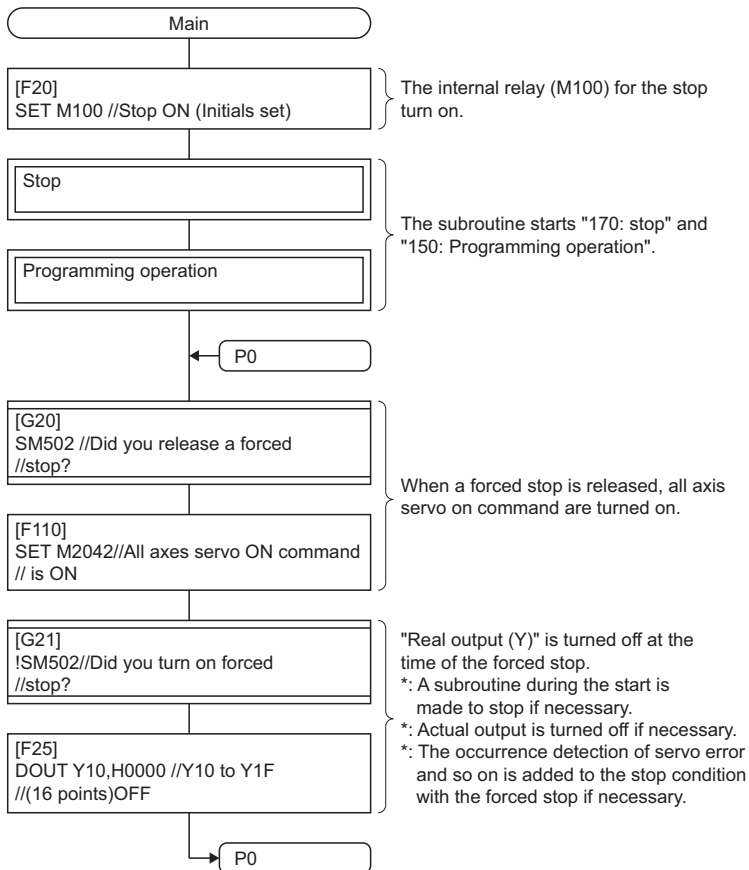

The subroutine that motion control was executed at the time of the forced stop did not stop and which started it for a while goes on, and it is executed by this sample program. Motion control is stopped after servo OFF is detected at the time of the forced stop in the inside of the subroutine. Resuming of the motion control is executed after all the axis servo ON command were turned on in this program and the detection of servo ON was done on the subroutine side when a forced stop is released.

■No.170: Stop

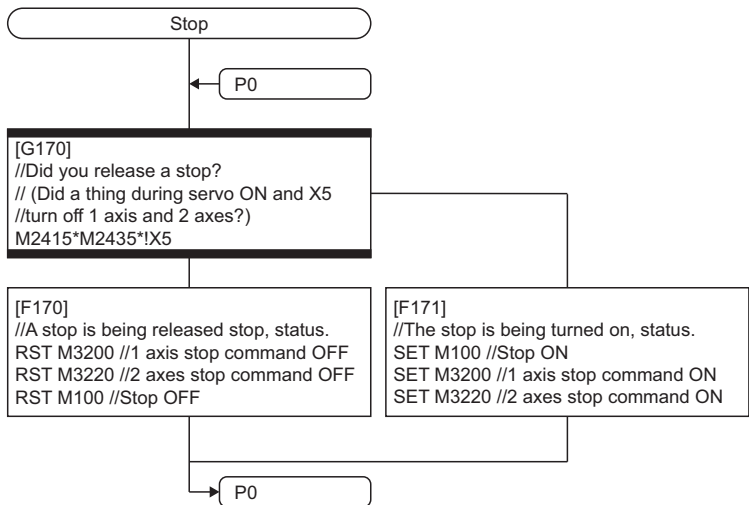

■No.150: Programming operation

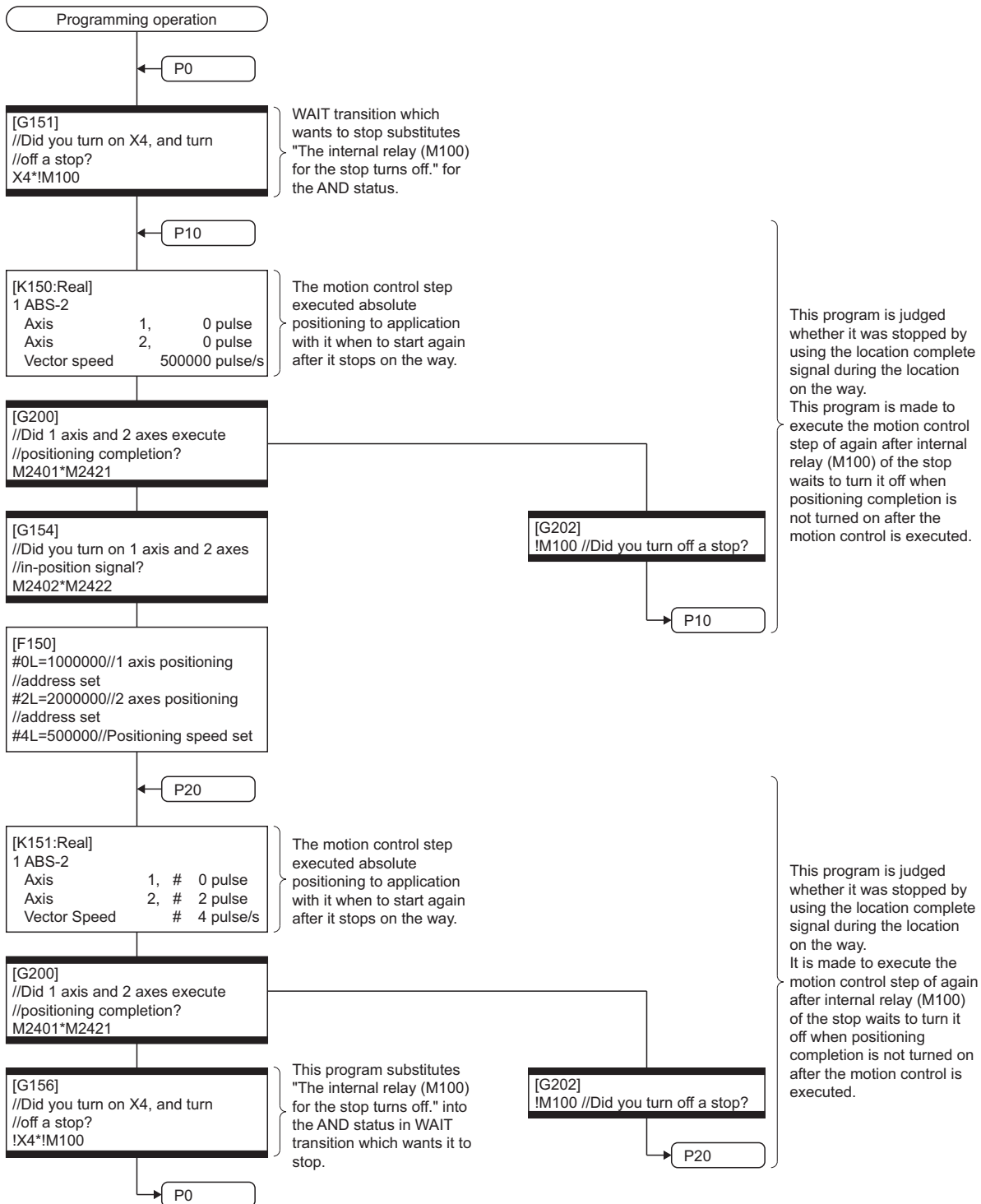

MEMO

A

REVISIONS

* The manual number is given on the bottom left of the back cover

Revision date	*Manual number	Description
June 2014	IB(NA)-0300239-A	First edition
March 2015	IB(NA)-0300239-B	<ul style="list-style-type: none"> ■ Added functions MOTION DEDICATED PLC INSTRUCTION (M(P)CHGA, M(P)CHGAS, M(P)CHGV, M(P)CHGVS, M(P)CHGT, M(P)BITWR/D(P)BITWR), Add-on Dedicated Function (MCFUN), Expansion of the number of connections for vision system ■ Added or modified parts SAFETY PRECAUTIONS, RELEVANT MANUALS, TERMS, Section 1.1, 2.2, 2.3, 4.5, 4.14, 4.16, 4.17, 4.18, 4.19, 7.1, 7.1.2, Appendix 1
June 2015	IB(NA)-0300239-C	<ul style="list-style-type: none"> ■ Added or modified parts TERMS, Section 2.2
February 2016	IB(NA)-0300239-D	<ul style="list-style-type: none"> ■ Added models R64MTCPU ■ Added functions Motion dedicated function (MCNST) ■ Added or modified parts SAFETY PRECAUTIONS, INTRODUCTION, RELEVANT MANUALS, TERMS, MANUAL PAGE ORGANIZATION, Section 1.1, 1.2, 2.2, 2.3, 4.2, 4.4, 4.15, 4.16, 4.19, 6.4, 6.5, 6.7, 6.8, 6.9, 7.1, 7.2, Appendix 1, Appendix 2, Appendix 3, WARRANTY
June 2016	IB(NA)-0300239-E	<ul style="list-style-type: none"> ■ Added or modified parts SAFETY PRECAUTIONS, INTRODUCTION, Section 4.1, 4.2, 4.5, 4.15, 4.16, 6.10 ■ Deleted parts Appendix 3
September 2016	IB(NA)-0300239-F	<ul style="list-style-type: none"> ■ Added functions Motion dedicated PLC instruction (M(P).MCNST/D(P).MCNST) ■ Added or modified parts TERMS, Section 1.1, 1.2, 2.2, 2.3, 3.1, 3.9, 3.10, 4.15, 4.16, 4.19, Appendix 1
December 2016	IB(NA)-0300239-G	<ul style="list-style-type: none"> ■ Added or modified parts SAFETY PRECAUTIONS, Section 1.1, 2.2, 2.3, 3.2, 3.4, 3.5, 4.15, 4.19, Appendix 1, Appendix 2
December 2017	IB(NA)-0300239-H	<ul style="list-style-type: none"> ■ Added or modified parts SAFETY PRECAUTIONS, RELEVANT MANUALS, MANUAL PAGE ORGANIZATION
June 2018	IB(NA)-0300239-J	<ul style="list-style-type: none"> ■ Added or modified parts SAFETY PRECAUTIONS, Section 4.16

Japanese manual number: IB-0300238-J

This manual confers no industrial property rights of any other kind, nor does it confer any patent licenses. Mitsubishi Electric Corporation cannot be held responsible for any problems involving industrial property rights which may occur as a result of using the contents noted in this manual.

©2014 MITSUBISHI ELECTRIC CORPORATION

WARRANTY

Please confirm the following product warranty details before using this product.

1. Gratis Warranty Term and Gratis Warranty Range

If any faults or defects (hereinafter "Failure") found to be the responsibility of Mitsubishi occurs during use of the product within the gratis warranty term, the product shall be repaired at no cost via the sales representative or Mitsubishi Service Company.

However, if repairs are required onsite at domestic or overseas location, expenses to send an engineer will be solely at the customer's discretion. Mitsubishi shall not be held responsible for any re-commissioning, maintenance, or testing on-site that involves replacement of the failed module.

[Gratis Warranty Term]

The gratis warranty term of the product shall be for one year after the date of purchase or delivery to a designated place. Note that after manufacture and shipment from Mitsubishi, the maximum distribution period shall be six (6) months, and the longest gratis warranty term after manufacturing shall be eighteen (18) months. The gratis warranty term of repair parts shall not exceed the gratis warranty term before repairs.

[Gratis Warranty Range]

- (1) The range shall be limited to normal use within the usage state, usage methods and usage environment, etc., which follow the conditions and precautions, etc., given in the instruction manual, user's manual and caution labels on the product.
- (2) Even within the gratis warranty term, repairs shall be charged for in the following cases.
 1. Failure occurring from inappropriate storage or handling, carelessness or negligence by the user. Failure caused by the user's hardware or software design.
 2. Failure caused by unapproved modifications, etc., to the product by the user.
 3. When the Mitsubishi product is assembled into a user's device, Failure that could have been avoided if functions or structures, judged as necessary in the legal safety measures the user's device is subject to or as necessary by industry standards, had been provided.
 4. Failure that could have been avoided if consumable parts (battery, backlight, fuse, etc.) designated in the instruction manual had been correctly serviced or replaced.
 5. Failure caused by external irresistible forces such as fires or abnormal voltages, and Failure caused by force majeure such as earthquakes, lightning, wind and water damage.
 6. Failure caused by reasons unpredictable by scientific technology standards at time of shipment from Mitsubishi.
 7. Any other failure found not to be the responsibility of Mitsubishi or that admitted not to be so by the user.

2. Onerous repair term after discontinuation of production

- (1) Mitsubishi shall accept onerous product repairs for seven (7) years after production of the product is discontinued. Discontinuation of production shall be notified with Mitsubishi Technical Bulletins, etc.
- (2) Product supply (including repair parts) is not available after production is discontinued.

3. Overseas service

Overseas, repairs shall be accepted by Mitsubishi's local overseas FA Center. Note that the repair conditions at each FA Center may differ.

4. Exclusion of loss in opportunity and secondary loss from warranty liability

Regardless of the gratis warranty term, Mitsubishi shall not be liable for compensation to:

- (1) Damages caused by any cause found not to be the responsibility of Mitsubishi.
- (2) Loss in opportunity, lost profits incurred to the user by Failures of Mitsubishi products.
- (3) Special damages and secondary damages whether foreseeable or not, compensation for accidents, and compensation for damages to products other than Mitsubishi products.
- (4) Replacement by the user, maintenance of on-site equipment, start-up test run and other tasks.

5. Changes in product specifications

The specifications given in the catalogs, manuals or technical documents are subject to change without prior notice.

TRADEMARKS

Ethernet is a registered trademark of Fuji Xerox Corporation in Japan.

Microsoft, Microsoft Access, Excel, SQL Server, Visual Basic, Visual C++, Visual Studio, Windows, Windows NT, Windows Server, Windows Vista, and Windows XP are either registered trademarks or trademarks of Microsoft Corporation in the United States and/or other countries.

The company names, system names and product names mentioned in this manual are either registered trademarks or trademarks of their respective companies.

In some cases, trademark symbols such as [™] or [®] are not specified in this manual.

IB(NA)-0300239-J(1806)MEE

MODEL: RMT-P-PRG-E

MODEL CODE: 1XB006

mitsubishi electric corporation

HEAD OFFICE : TOKYO BUILDING, 2-7-3 MARUNOUCHI, CHIYODA-KU, TOKYO 100-8310, JAPAN
NAGOYA WORKS : 1-14, YADA-MINAMI 5-CHOME, HIGASHI-KU, NAGOYA, JAPAN

When exported from Japan, this manual does not require application to the
Ministry of Economy, Trade and Industry for service transaction permission.

Specifications subject to change without notice.